

Motor Starters and Enclosed Product

Open & Enclosed pre-wired motor starters and enclosed contactors for any application

Starters & Enclosed Products



KWIKstarters

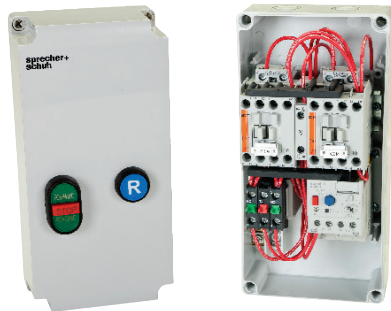

Enclosed Contactor

In addition to selling “open” components, Sprecher + Schuh also offers a full array of preassembled and enclosed products ready to install when they reach your dock.

Standard or customized

The cataloged products in this section comprise Sprecher + Schuh’s standard offerings. In most cases, engineering drawings and bills-of-material have already been created and assembly procedures have been standardized. Generally speaking, lead times are shorter on these standard items.

- Fractional Manual Starters
- Enclosed contactors
- Magnetic motor starters
- KWIKstarters
- Combination starters
- Explosion-proof starters
- Multi-speed starters
- Reduced voltage starters
- Pump controllers
- Softstarters (see Section D)
- Type E/F combination controllers (see Section F)

Your sales representative and our Engineering department will also work with you to customize any of our standard pre-assembled or enclosed products to suit your exact specifications. Any combination of enclosure types, pilot devices, control power transformers, meters and other modifications can be combined to provide exactly the panel you need.



UL/CSA approved shop

Sprecher + Schuh’s assembly operations are UL Approved UL508A and CSA certified. This means, upon customer request, we can build UL 508A Listed and CSA compliant panels that satisfy the most rigorous UL inspection. Regardless of whether your panel has a UL508A Listing, panels built by Sprecher + Schuh adhere to UL mandated design and wiring standards.

Built with quality and pride

Every panel built by Sprecher + Schuh is meticulously designed and constructed. Where possible, all panels are laid out with generous wiring space. Control wiring is neatly bundled and tied to the

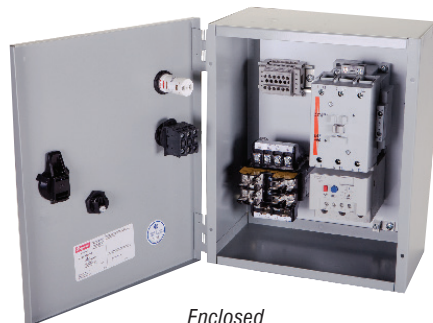

Enclosed Non-combination Starter

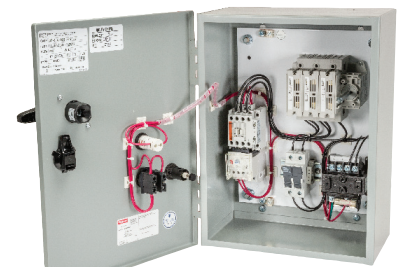

Fusible Combination Starter

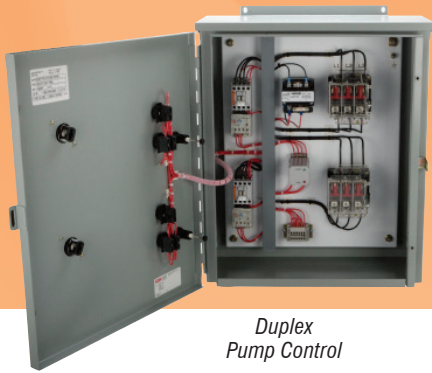

*Duplex
Pump Control*

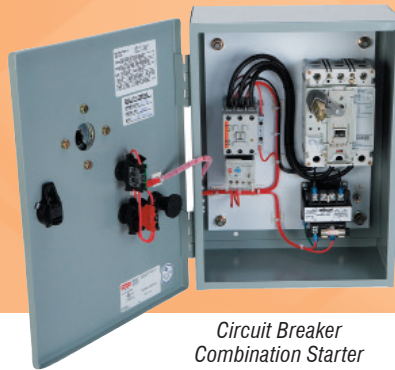

*Circuit Breaker
Combination Starter*



*Pump Control
Panel*

back pan. Outsourced components are industrial control quality from name brand manufacturers. Control wiring and device function is electrically tested before the panel leaves our facility.

ISO 9001 and ATEX Certified

Sprecher + Schuh is committed to a quality system, focused on customer solutions. This is achieved through superior products and services, excellent customer service, technical expertise, supplier partnerships, and industry leadership.

Our facility is ISO 9001 certified. That was the catalyst in allowing Sprecher + Schuh to obtain Atmospheres Explosives certification (ATEX). ATEX certification permits us to build explosion-proof equipment and panels to be supplied across the European Union, including Canada.

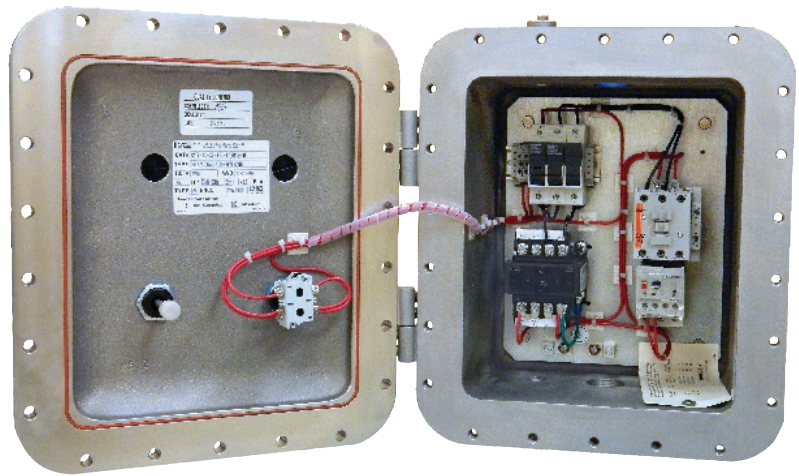

*Explosion Proof
Non-combination Starter*

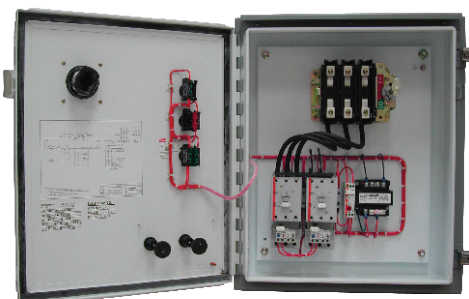

Part-Winding Starter

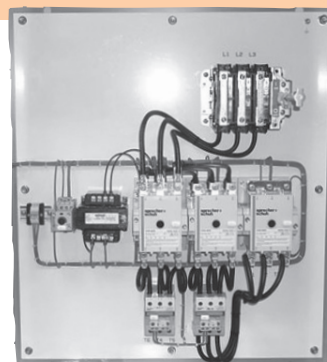

Multi-Speed Starter

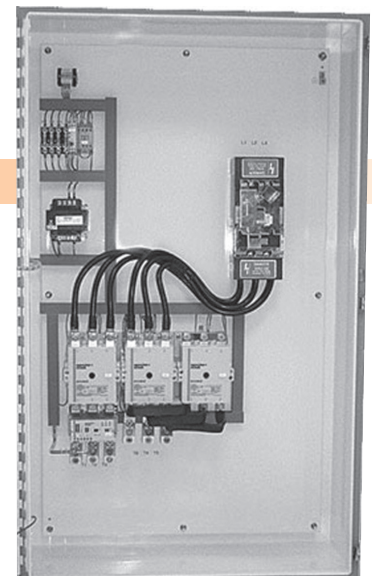

Wye-Delta Starter

Catalog Number Coding

Standard Starters and Enclosed Contactors

FMS and KWIKstarters do not use these principles

CAT 7-30 - 480

Contactors or Starter Type

Contactor Size

Coil Code (or CPT)

Non-reversing

- CA** Contactor
- CAT** Starter
- CBT** Starter (Single Phase)
- CATN** Starter (NEMA- Three Phase)
- CBTN** Starter (NEMA- Single Phase)

Reversing

- CAU** Reversing Contactor
- CBU** Reversing Contactor (Single Phase)
- CAUT** Reversing Starter
- CBUT** Reversing Starter (Single Phase)
- CAUTN** Reversing Starter (NEMA)

Multi-speed

- CAZTT** Multispeed-Two Wind. (Conts/VAR TQ)
- CAZHT** Multispeed-Two Wind. (Const. HP)
- CAETT** Multispeed-One Wind. (Conts/VAR TQ)
- CAEHT** Multispeed-One Wind. (Const. HP)

Reduced Voltage

- CAAT** Autotransformer Starter
- CAYT** Wye-Delta Starter
- CAPWT** Part Winding Starter

Pump Panels

- CAPT** Simplex Pump Panel
- CAPTN** Simplex Pump Panel (NEMA Size)
- CADPT** Duplex Pump Panel

Small - Series CA7 ①

- 7-9(E)
- 7-12(E)
- 7-16(E)
- 7-23(E)
- 7-30(E)
- 7-37(E)
- 7-43(E)
- 7-55(E)
- 7-60(D)
- 7-72(D)
- 7-85(D)
- 7-97(D)

Medium - Series CA9

- 9-116(-EI)
- 9-146(-EI)
- 9-190(-EI)
- 9-205(-EI)
- 9-265(-EI)
- 9-305(-EI)
- 9-370(-EI)
- 9-400-EI
- 9-460-EI
- 9-580-EI
- 9-750-EI
- 9-860-EI
- 9-1060-EI

AC

- 24Z
- 120
- 220W
- 277
- 415
- 480
- 600

DC

- 12E
- 24E, 24DD
- 24W
- 36E
- 48E
- 110E, 110DD
- 220E

AC/DC

- 24W
- 48W
- 120W
- 480W

Control Transformer

Code	Primary	Secondary
XA	208	120
XB	240	120
XC	480	120
XD	575	120
XE	240	24
XF	480	24
XG	380	110

For additional **Control Transformer Codes**, refer to Modification pages in this section.

**This illustration is for reference only.
Turn to the appropriate page to determine
specific catalog number.**

① (D) & (E) suffix designates contactors with DC coils

EED

TB20

G

3

Overload Relay

Short-Circuit / Disconnect

Enclosure

Enclosure Cover Control

Options

CEP7 Second Generation - Solid State CA7-9 thru CA9-1060-EI

- D1...** CEP7 O/L Relay, 3Ø, Class 10, man. reset
- E...** CEP7S O/L Relay, 1Ø, (selectable)
- E...** CEP7 O/L Relay, 3Ø, (selectable)
- CT..** Current Transformers

CT7N - Bimetallic Thermal

CA7-9 thru CA7-97

- ...A-C** CT7N O/L Relay, Class 10, manual or automatic reset
- ...P** CT7N O/L Relay, Class 10, manual or automatic reset, separate mount

- G** General Purpose - Type 1
- D** Dusttight - Type 12
- W** Watertight - Type 4
- C** Watertight Corrosion Resistant - Type 4X
- R** Raintight - Type 3R
- E** Explosion proof - Type 7

Non-Reversing

- 1** Pilot Light Only
- 2** Pilot Lights (2) Only
- 3** "Start-Stop" PB
- 4** "On-Off" PB
- 5** "Hand-Auto" S/S
- 6** "Off-On" S/S
- 7** "Hand-Off-Auto" S/S
- 9** "Emergency Stop" PB
- 0** None

Reversing

- 2** Pilot Lights (2) Only
- 3** "For-Stop-Rev" PB
- 4** "Up-Stop-Down" PB
- 5** "Open-Stop-Close" PB
- 6** "For-Off-Rev" S/S
- 7** "Up-Off-Close" S/S
- 8** "Open-Off-Close" S/S
- 0** None

Multi-speed

- 2** Pilot Lights (2) Only
- 3** "High-Stop-Low"
- 4** "Fast-Stop-Slow"
- 5** "High-Off-Low"
- 6** "Fast-Off-Slow" S/S

For additional **Cover Control Codes**, refer to Modifications page in this section.

For complete listing of **Option Codes**, refer to Modification pages in this section.

Through-the-Door Operated Combo					
Thermal Magnetic Circuit Breaker		Fusible Disconnect		Non Fusible Disconnect	
TB(H)15	15 Amp	JF61	600V/30A	JU61	600V/30A
TB20	20 Amp	JF62	600V/60A	JU62	600V/60A
TB25	25 Amp	JF63	600V/100A	JU63	600V/100A
	↓ thru ↓	JF64	600V/200A	JU64	600V/200A
		JF65	600V/400A	JU65	600V/400A
		JF66	600V/600A		
		JF67	600V/800A		
Blank	None	Blank	None	Blank	None

* TBH represents high interrupt capacity breaker

C

Starters & Enclosed Products

NEMA / UL Enclosure Type Definitions







For a degree of protection against:	NEMA / UL Type (IP Equivalent ①)								
	Indoor Use			Outdoor Use		Indoor or Outdoor Use			
	1 (IP23)	12 (IP55/65)	13 (IP65)	3R	3 (IP64)	4 (IP66)	4X (IP66)	6P	6 (IP67)
Incidental contact with enclosed equipment	✓	✓	✓	✓	✓	✓	✓	✓	✓
Falling dirt	✓	✓	✓	✓	✓	✓	✓	✓	✓
Rust	✓	✓	✓	✓	✓	✓	✓	✓	✓
Circulating dust, lint, fibers and flyings		✓	✓		✓	✓	✓	✓	✓
Windblown dust					✓	✓	✓	✓	✓
Falling liquids and light splashing		✓	✓		✓	✓	✓	✓	✓
Rain (limited water allowed inside)				✓	✓	✓	✓	✓	✓
Rain (no water allowed inside)					✓	✓	✓	✓	✓
Snow and sleet				✓	✓	✓	✓	✓	✓
Hosedown and splashing water						✓	✓	✓	✓
Occasional prolonged submersion								✓	✓
Oil or coolant spraying or splashing			✓						
Corrosive agents							✓	✓	
Occasional temporary submersion								✓	✓

Explosion-Proof Enclosure Type Definitions

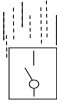
NEMA Classifications - Marked with Rated Class, Division, and Group	
NEMA 7	For use in indoor locations classified as Class I, Groups A, B, C or D, as defined in the National Electrical Code
NEMA 8	For use in indoor or outdoor locations classified as Class I, Groups A, B, C or D, as defined in the National Electrical Code - oil immersed
NEMA 9	For use in indoor locations classified as Class II, Groups E, F or G, as defined in the National Electrical Code
Summary of NEC Classes and Group Examples	
Group	Class I (Potentially explosive gas or vapor)
A	Acetylene
B	Hydrogen, Ethylene Oxide, Propylene Oxide
C	Ether, Hydrogen Sulfide, Hydrazine, Nitroethane
D	Methane, Acetone, Benzene, Gasoline, Naptha
Group	Class II (Potentially explosive dusts)
E	Metallic Dusts (all metals)
F	Carbonaceous Dusts (coal, asphalt, etc.)
G	Nonconductive Dusts (grain, drugs, pesticides, plastics, dyes, etc.)
Summary of NEC Divisions	
Division 1	Potentially explosive substance present under normal operating conditions
Division 2	Potentially explosive substance present under abnormal operating conditions

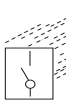
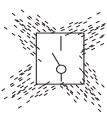
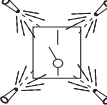
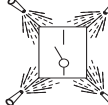
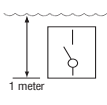
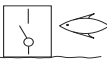
① IP Equivalents are only approximate. It is the responsibility of the user to verify the enclosure rating necessary for the given application.

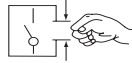
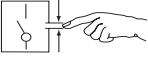
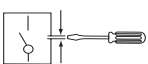
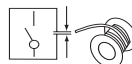
IP Ratings Definitions

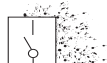
<p>IP Ratings Definitions</p> <p>The first IP number (left side of chart) is protection against solid objects. The second IP number (across top) is protection against liquids. The chart itself shows degrees of protection according to IEC 529.</p>	 No protection IP...0	 Protected against vertically falling drops of water (condensation) IP...1	 Protected against dripping water with enclosure up to 15° from vertical IP...2	 Protected against sprayed water up to 60° from vertical IP...3	 Protected against sprayed water from all directions (limited ingress permitted) IP...4	 Protected against low pressure water jets from all directions (limited ingress permitted) IP...5	 Protected against strong jets of water from all directions IP...6	 Protected against immersion up to one meter IP...7	 Protected against long periods of immersion under pressure IP...8
<p>IP0...</p>  No protection IP00									
<p>IP1...</p>  Protected against solid objects up to 50mm (accidental touch by hands) IP10		IP11	IP12						
<p>IP2...</p>  Protected against solid objects up to 12mm (fingers, knuckles) IP20		IP21	IP22	IP23					
<p>IP3...</p>  Protected against solid objects up to 2.5mm (tools, wires) IP30		IP31	IP32	IP33	IP34				
<p>IP4...</p>  Protected against solid objects up to 1mm (wires) IP40		IP41	IP42	IP43	IP44				
<p>IP5...</p>  Protected against dust (limited ingress permitted) IP50				IP53	IP54	IP55	IP56		
<p>IP6...</p>  Totally protected against dust IP60						IP65	IP66	IP67	

Custom Control Panels

Designed and built to meet *Your* needs

C
Custom Control Panels



Need Custom Control Panels? You Got It

Sprecher + Schuh is your go to builder for custom motor control panels. Our panel shops are UL508 and CSA approved. This means our knowledgeable team can design your panel for custom applications to meet UL/CSA, ATEX, UL1203, and CE standards. Our engineering and custom quotes staff work with the customer one-on-one in designing a motor control panel that best fits the customer's needs. No job is too small or too big for our staff to take on.

We continuously strive to develop innovative, new products and improve existing designs. We constantly strive to maintain a superior level of service including our ISO 9001 Certification.

Our large panel shop is designed to accommodate our customers' needs. We stock not only Sprecher + Schuh components but also MCCB and popular enclosures in a variety of sizes and types (metallic, non-metallic, and explosion-proof). This means we can design, assemble, wire, and quickly ship a variety of custom panels.

What Can We Build For You?

Regardless of your industry or custom control panel needs, we at Sprecher + Schuh have the engineering experience and manufacturing facilities to design and build your panels. Whether your need is to design an OEM panel that will be repeated, or a one-of-a-kind, we have an experienced engineering and quality control team dedicated to providing the best solution to your custom control panels. Our manufacturing facilities are staffed with experienced wiring and installation technicians, ensuring your custom panel meets safety and performance criteria. Through this commitment to service, and never-ending attention to detail, we continue to be the first and last words in motor protection.

ISO9001, UL508 & UL1203 (NNNY) 
ATEX
Certified Panel Shop

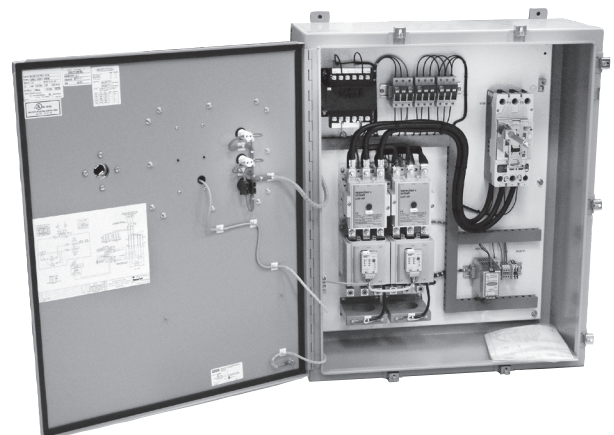

Custom Built Panels

Custom built to your specifications!

- Multi-Motor Starter Panels
- Combination & Non-Combination Motor Starters
- Reduced Voltage Starters
- Softstarter Panels (see Section D)
- Multi-plex Pump Panels
- Door-in-Door Panels
- Explosion-Proof Starters
- UL508/CSA Labeled Custom Panels
- ATEX Explosion Proof Panels
- Labeled Service Entrance Rated Panels
- and many more!



For your
*Custom
application*
contact:
customquotes@sprecherschuh.com

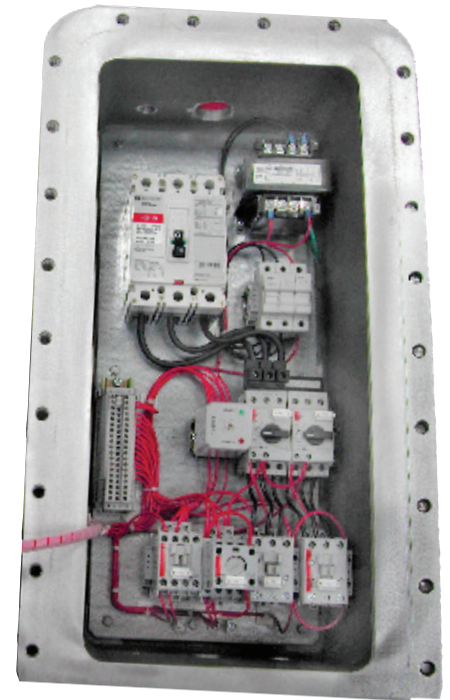

Fractional Manual Starters

Easy, simple starting of Motors up to 1 HP

Sprecher + Schuh Fractional Manual Starters (FMS) consist of a snap switch combined with a thermal overload device operating on the solder-ratchet principle. To reset the overload mechanism, the switch lever is moved to the OFF position. The motor can be restarted by simply pushing the switch lever to the ON position. The switch is designed to prevent being held closed under a sustained motor overload.

Easy to Order

FMS Starters are easy to order. Simply choose a 1-Pole or 2-Pole with or without the Neon pilot light and then order the required Heater Element. You're done!

Typical Applications

Starting and overload protection of small 1-phase 115...230V AC/DC or 277 VAC motors used on the following applications:

- Unit heaters
- Fans
- Stokers
- Pumps
- Refrigeration compressors



Fractional Manual Starter

	Ratings (HP)		Poles ⊕	Type 1 General Purpose Surface Mounting Catalog Number
	115...230V AC	277V AC		
	Toggle Switch Only			
	1	1	1-Pole	FMS-TAX4
	1	1	2-Pole	FMS-TAX5
	Toggle Switch with Neon Pilot Light (115 or 230V)			
	1	1	1-Pole	FMS-TAX216
FMS with Neon Pilot light	1	1	2-Pole	FMS-TAX217

Heater Element (Required) ①

Full Load Amps	Catalog Number
0.17	P1
0.20	P2
0.25	P3
0.32	P4
0.39	P5
0.46	P6
0.57	P7
0.71	P8
0.79	P9
0.87	P10
0.98	P11
1.08	P12
1.19	P13
1.30	P14
1.43	P15
1.58	P16
1.75	P17
1.88	P18
2.13	P19
2.40	P20
2.58	P21
2.92	P22
3.09	P23
3.32	P24
3.37	P25
4.16	P26
4.51	P27
4.93	P28
5.43	P29
6.03	P30
6.83	P31
7.72	P32
8.24	P33
8.90	P34
9.60	P35
10.8	P36
12.0	P37
13.5	P38
15.2	P39

Optional Locking Attachment

	Accessory Locking Attachment For locking toggle switch in ON or OFF position.	Catalog Number
		FMS-N1

Selecting Heater Elements ③

The "Full Load Amps" listed in the table can be used for heater element selection. The rating of the relay in amperes at 40°C is 115% of the "Full Load Amps" (FLA) listed for the catalog number. Refer to the motor nameplate for the full load current, the service factor, and/or the motor classification by application and temperature rise. Use this motor nameplate information, the application rules and the FLA listed in the table to determine the Heater Element catalog number for motors rated for Continuous Duty.

1. For the Same Temperature at the Controller and Motor : Select the Heater Element with the listed FLA nearest the full load value shown on the motor nameplate.
2. For Higher Temperature at the Controller than at the Motor : If the full load current value shown on the motor nameplate is between the listed FLAs, select the Heater Element with the next higher value.
3. For a Lower Temperature at the Controller than at the Motor : If the full load current value shown on the motor nameplate is between the listed FLAs , select the Heater Element with the next lower value.
4. All other motors rated for continuous duty (includes motors with marked service factor 1.0): Select the Heater Element one rating smaller than determined by rules in 1, 2 and 3.

Ordering Instructions

Order FMS Catalog Number
Order Required FMS Heater Element(s) ①
Order Optional FMS Locking Attachment

- ① One heater is required for 1-pole or 2-pole applications. See schematic on next page.
- ② Two-pole selections are applicable for 3/4 HP at 115...230V DC.
- ③ Rule 2 and 3 temperature difference not to exceed more than 10°C (18°F).

This page has moved. See new NEMA Starters Section starting at page 101.1

Technical Information

Eutectic Operation

Thermal overload devices using the eutectic alloy method are spring loaded in the normal, or reset, position. When the heater is cold, the solder is solid and holding the spring loaded ratchet. When FLA is passed through the heater, and if excess current flows, then the solder will melt and allow the ratchet mechanism to turn. This result trips the device. The device is reset by turning the switch to the OFF position and allowing it to cool.

P.L.: Pilot Light (Optional)

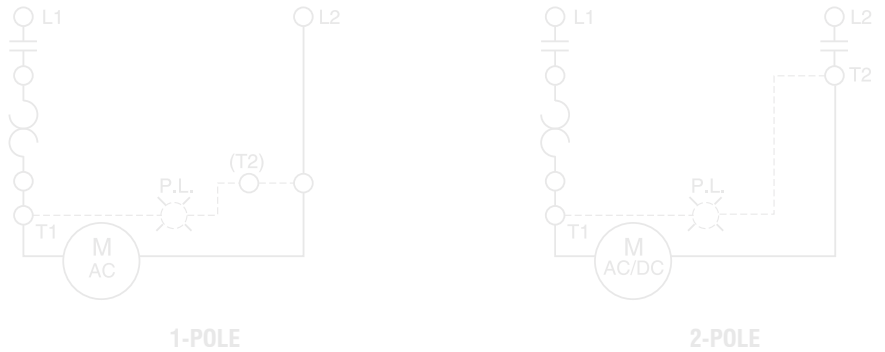

Standards Compliance

- UL 508
- EN60947-4-1
- CSA C22.2, No. 14

Certifications

- UL Listed - Enclosed Products (File No. E14841; Guide No. NLRV)
- CSA Certified (File No. LR 1234)
- American Bureau of Shipping (ABS)
- CE marked

Trip Time

- Class 20
- Reset Time: The actual time to reset will vary based on the ambient temperature surrounding the overload. Under most conditions it will take from approximately 90 seconds up to 5 minutes for the solder to solidify enough for the overload to be reset. When this happens, the overload will not be able to be reset by pushing the reset button. The ratchet mechanism inside the overload block will spin freely until the solder has solidified.

Dimensions

FMS Type 1 General Purpose Starter Dimensions

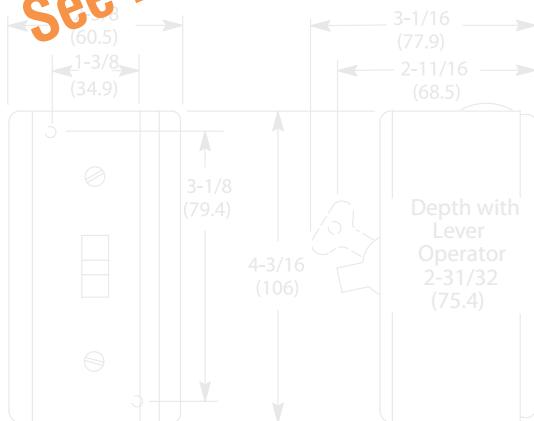

TIME - Current Characteristics at 40°C

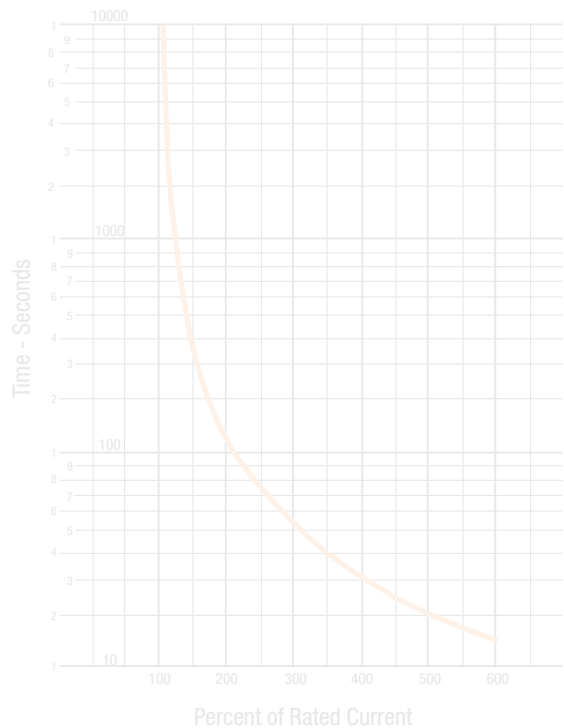

NOTE: Trip will occur at 115% of FLA

See new NEMA Starters Section starting at page 101.1

FMS Fractional Manual Starters

KWIKstarters

Preassembled or build from stock – Easy, fast, economical enclosed starters for applications up to 30HP

KWIKstarters

Sprecher + Schuh offers a broad selection of pre-assembled or “build-from-stock” starters housed in a high impact, non-metallic, cUL Approved, Type 1, 12, 4, 4X enclosure. Built for convenience, space savings and economy, KWIKstarters are efficiently designed to use stock CA7 contactors and CEP7 or CT7N overloads usually stocked by distributors. Contactor and overload are either pre-wired and pre-mounted onto the enclosure’s built-in DIN-rail or may be ordered as separate components. Ample knockouts and open terminals guarantee quick, no fuss wiring.

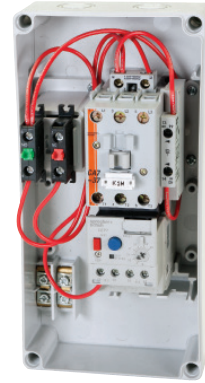

KWIKstarters are also available with our advanced CEP7 Solid State Overload Relay (select appropriate overload relay code for this option)

Sized for most industrial applications

KWIKstarters control motors up to 30HP @ 460V in two sizes of enclosures, measuring only 208 x 98mm (7.4” x 3.9”) or 250 x 125mm (9.85” x 4.93”) for our larger sizes. This covers over 85% of industrial motor control applications in a very compact package that can be mounted adjacent to or directly on equipment.



Most KWIKstarters are equipped with Thermal Overload protection as standard

Thermal overload protection

KWIKstarters, sized 9 to 23 amps, are equipped with Sprecher + Schuh’s CT7N bimetallic thermal overload relay as standard. The consistent high quality of our thermal overload relays is ensured by a complex current calibration procedure performed after each unit is at full operating temperature.

Solid state overload options

KWIKstarters, sizes 9 to 23 amps, can also be supplied with Sprecher + Schuh’s CEP7 solid state overload relay. The CEP7 Overload is standard on larger (sizes 30 to 43 amps) and all reversing KWIKstarters. The CEP7 solid state overload relays measure motor current directly through integrated current transformers and on board electronics. The electronics provide increased accuracy and numerous other advantages over electromechanical relays. Learn more about Sprecher + Schuh overload relays in Section B of this catalog.

Build it yourself...

KWIKstarters may be assembled from stock components. Just grab a CA7 contactor and overload of your choice and snap them into the enclosure. Minimal wiring is required and assembly can be completed in minutes.



Start-Stop or Reset only

Hand-Off-Auto with Pilot Light

Emergency Stop

Multi-Function

Forward-Stop-Reverse options

Combination KWIKstarters

CX7 KWIKstarters

Type E/F Combination Motor Controllers

KTA7 can be applied in combination with a CA7 contactor for remote control and an enclosure with matching environmentally approved thru-the-door handle disconnect mechanism to meet all requirements for a Construction Type E or F Combination Starter. This selection of individual Combination starters are smaller and are less expensive than Classic Construction Type A (Fusible), or Type C (Thermal-magnetic Molded Case Circuit Breaker), as offered in the following pages.

Sprecher + Schuh has developed a KWIKStarter version of the Combination Motor Controller which can be easily field assembled or can be purchased as a factory assembly. For details and catalog number selection on these economical combination starter alternatives turn to page F98.

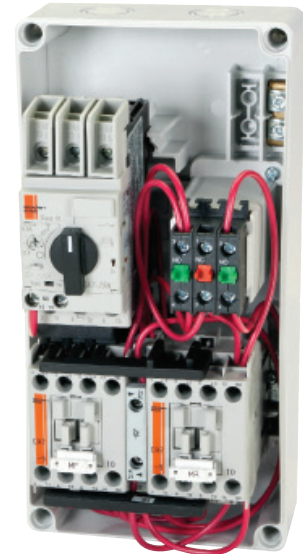



Why Type E/F?

NEC430-53.C.1 defines that the short-circuit protection of a single motor branch circuit shall be provided by a set of fuses or a thermal-magnetic molded case circuit breaker. Alternatively NEC 430-53.C.6 also permits the use of a Self-protected Combination Motor Controller can be used to not only provide short-circuit protection for a single motor branch circuit but also provide a means of disconnect and overload protection. Self-protected Combination motor controllers like KTA7 can be combined with CA7, providing a coil for cover control or remote operation. This results in a Construction Type E or Type F (based on selection depending on published UL ratings) Combination starter per UL508. For details of UL, NEC and CSA application standards and rules please see our online white paper, Applying KT7 Motor Controllers.

See page F98 for
Type E/F
CX7
KWIKstarters

KWIKstarters with CT7N or CEP7 Overload Relays ①②

Cover Control/ Enclosure (KS7-COS1/COS4)	Maximum Horsepower						Total Aux. Contacts Installed		cUL Approved- Type 1/12/4/4X IP66	Dimen- sion Code
	Single Ø		Three Ø							
	115V	230V	200V	230V	460V	575V	NO	NC	Catalog Number	③
KWIKstarter with Start & Raised Stop ④⑤										
	1/2	1 1/2	~	~	~	~	1 ②	0	CBK7-9-*-◆-P2 CAK7-9-*-◆-P2	Q1
	~	~	2	2	5	7 1/2				
	1/2	2	~	~	~	~	1 ②	0	CBK7-12-*-◆-P2 CAK7-12-*-◆-P2	Q1
	~	~	3	3	7 1/2	10				
	1	3	~	~	~	~	1 ②	0	CBK7-16-*-◆-P2 CAK7-16-*-◆-P2	Q1
	~	~	5	5	10	15				
	2	3	~	~	~	~	1 ②	0	CBK7-23-*-◆-P2 CAK7-23-*-◆-P2	Q1
	~	~	5	7 1/2	15	15				
KWIKstarter with Reset										
	1/2	1 1/2	~	~	~	~	1	0	CBK7-9-*-◆-P0 CAK7-9-*-◆-P0	Q1
	~	~	2	2	5	7 1/2				
	1/2	2	~	~	~	~	1	0	CBK7-12-*-◆-P0 CAK7-12-*-◆-P0	Q1
	~	~	3	3	7 1/2	10				
	1	3	~	~	~	~	1	0	CBK7-16-*-◆-P0 CAK7-16-*-◆-P0	Q1
	~	~	5	5	10	15				
	2	3	~	~	~	~	1	0	CBK7-23-*-◆-P0 CAK7-23-*-◆-P0	Q1
	~	~	5	7 1/2	15	15				

Coil Codes ⑥

A.C. Coil Code	Voltage Range		Control Source	
	50 Hz	60 Hz	CBK7	CAK7
24Z	24V	24V	Separate	Separate
120	110V	120V	Common	Separate
220W	200V-220V	208V-240V	Common	Common
277	240V	277V	Common	~
415	400-415V	~	~	Common
480	440V	480V	~	Common
600	550V	600V	~	Common

Control Circuit Note

Common: Coils are assumed to be common with the line voltage and will be connected to the line source (L1-L2) per the table.



Separate: Coils are assumed to be from a separate source and will not be connected to the line source per the table.

Ordering Instructions

Specify Catalog Number	
Replace (*) with Coil Code Replace (◆) with O/L Relay	See this page See page C30
Important Note: KWIKstarters are only designed to accommodate CT7N Thermal Overload Relays or CEP7 Solid State Overload Relays. Select O/L Relay Code from page C30.	

- ① KWIKstarters are designed for three-wire control circuits. Two-wire (maintain) control can be accomplished by adding pushbutton latch KS7-PLA.
- ② A special design NO auxiliary contact (Cat.# KS7-PCK) is used as the holding circuit interlock, as well as, the START button interface. It is not available for other use.
- ③ Refer to page C33 for dimensional information.
- ④ STOP button also functions as RESET button. Plastic Bezel is standard.
- ⑤ Other voltages available, see Section A.
- ⑥ Use CT7N or CEP7-ED/CEP7-EE overload.

KWIKstarters with CT7N or CEP7 Overload Relays ①④⑤⑥

Cover Control/ Enclosure (KS7-COS1/COS4)	Maximum Horsepower						Total Aux. Contacts Installed		cUL Approved- Type 1/12/4/4X IP66	Dimension Code
	Single Ø		Three Ø							
	115V	230V	200V	230V	460V	575V	NO	NC		
KWIKstarter with Start & Raised Stop ④⑤										
	1/2	1 1/2	~	~	~	~	1 ②	0	CBK7-9E-*-◆-P2	Q1
	~	~	2	2	5	7 1/2			CAK7-9E-*-◆-P2	
	1/2	2	~	~	~	~	1 ②	0	CBK7-12E-*-◆-P2	Q1
	~	~	3	3	7 1/2	10			CAK7-12E-*-◆-P2	
	1	3	~	~	~	~	1 ②	0	CBK7-16E-*-◆-P2	Q1
	~	~	5	5	10	15			CAK7-16E-*-◆-P2	
	2	3	~	~	~	~	1 ②	0	CBK7-23E-*-◆-P2	Q1
	~	~	5	7 1/2	15	15			CAK7-23E-*-◆-P2	
KWIKstarter with Reset										
	1/2	1 1/2	~	~	~	~	1	0	CBK7-9E-*-◆-P0	Q1
	~	~	2	2	5	7 1/2			CAK7-9E-*-◆-P0	
	1/2	2	~	~	~	~	1	0	CBK7-12E-*-◆-P0	Q1
	~	~	3	3	7 1/2	10			CAK7-12E-*-◆-P0	
	1	3	~	~	~	~	1	0	CBK7-16E-*-◆-P0	Q1
	~	~	5	5	10	15			CAK7-16E-*-◆-P0	
	2	3	~	~	~	~	1	0	CBK7-23E-*-◆-P0	Q1
	~	~	5	7 1/2	15	15			CAK7-23E-*-◆-P0	

Coil Codes ⑤

DC Coil Codes	Voltage
12E	12V
24E	24V

Ordering Instructions

Specify Catalog Number	
Replace (*) with Coil Code	See this page See page C30
Replace (◆) with O/L Relay	
Important Note: KWIKstarters are only designed to accommodate CT7N Thermal Overload Relays or CEP7 Solid State Overload Relays. Select O/L Relay Code from page C30.	

- ① KWIKstarters are designed for three-wire control circuits. Two-wire (maintain) control can be accomplished by adding pushbutton latch KS7-PLA.
- ② A special design NO auxiliary contact (Cat.# KS7-PCK) is used as the holding circuit interlock, as well as, the START button interface. It is not available for other use.
- ③ Refer to page C33 for dimensional information.
- ④ STOP button also functions as RESET button. Plastic Bezel is standard.
- ⑤ CA7-9E...23E with electronic coils are not interchangeable with non-electronic DC or AC coils
- ⑥ Use CT7N or CEP7-ED/CEP7-EE overload.

KWIKstarters with CEP7 Overload Relays ①

Enclosure (KS7-C2S4)	Maximum Horsepower						Total Aux. Contacts Installed		cUL Approved- Type 1/12/4/4X IP66	Dimension Code
	Single Ø		Three Ø				NO	NC		
	115V	230V	200V	230V	460V	575V			Catalog Number	
	KWIKstarters with AC Coil									
	2	5	~	~	~	~	1	0	CBK7-30-*-ETD-P▼	Q2
	~	~	7-1/2	10	20	25			CAK7-30-*-◆-P▼	
	3	5	~	~	~	~	1	0	CBK7-37-*-ETD-P▼	Q2
	~	~	10	10	25	30			CAK7-37-*-◆-P▼	
	3	7-1/2	~	~	~	~	1	0	CBK7-43-*-ETD-P▼	Q2
	~	~	10	15	30	30			CAK7-43-*-◆-P▼	

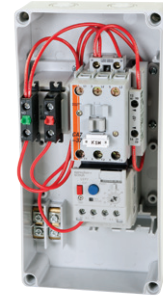

Control Circuit Note
Common: Coils and pilot devices in the control circuit are assumed to be common with the line voltage and will be connected to the line source (L1-L2) per the table.
Separate: Coils and pilot devices in the control circuit are assumed to be from a separate source and will not be connected to the line source per the table. Pilot lights are 240 VAC maximum.

Replace ◆ with one of the following Overload Relays

For use with KWIKstarter...	Amp Range	Overload Relay Code (◆)	Catalog No. (of Overload Relay used)
3-Phase / Manual Reset / Class 10			
CAK7-30...43	1.0...5.0	D1CD	CEP7-ED1CD
	3.2...16	D1DD	CEP7-ED1DD
	5.4...27	D1ED	CEP7-ED1ED
	9...45	D1FD	CEP7-ED1FD
3-Phase / Auto or Manual Reset / Class 10, 15, 20, 30			
CAK7-30...43	1.0...5.0	ECD	CEP7-EECD
	3.2...16	EDD	CEP7-EEDD
	5.4...27	EED	CEP7-EEED
	9...45	EFD	CEP7-EEFD

Pilot Device Options (includes reset) ②③

Pushbutton Description	Replace ▼ in catalog number with
START-STOP Multi-function (shown)	3U
I-O Multi-function	4U
OFF-ON 2-Position Selector switch	6
Pilot Light Red (LED) with START-STOP Multi-function	1R3U
Pilot Light Red (LED) with I-O Multi-function	1R4U

Optional CA7 Modifications (Factory Assembled)

Description	Add to end of catalog number
Electronic Interface	-JE
Surge Suppressor RD	-C
Surge Suppressor Varistor	-V
Additional NC Contact	-L01
Additional NO Contact	-L10

Coil Codes (*) ④⑤

A.C. Coil Code	Voltage Range		Control Source	
	50 Hz	60 Hz	CBK7	CAK7
24Z	24V	24V	Separate	Separate
120	110V	120V	Common	Separate
220W	200-220V	208-240V	Common	Common
277	240V	277V	Common	~
415	400-415V	~	~	Common
480	440V	480V	~	Common
600	550V	600V	~	Common

Ordering Instructions

Specify Catalog Number	See this page only
Replace (*) with Coil Code	
Replace (◆) with O/L Relay	
Replace (▼) with Pilot Device Option	

- ① Use CEP7-ED/CEP7-EE overloads only. Single-phase applications utilize CEP7S-EETD only.
- ② Plastic Bezel is standard. Pilot Device options include D7-BX_ Base Mounted contact blocks. See page H69 for more information.
- ③ Refer to page C31 for wiring diagram and C34 for dimensional information.
- ④ Other voltages available, see Section A.
- ⑤ One and only one Pilot Device option must be selected. If Pilot Light option is selected then coil voltage must be 24V, 120V or 240V AC only.
- ⑥ CPT not possible with KS7-C2S4 (Q2) enclosure.

KWIKstarters with CEP7 Overload Relays ❶

Enclosure (KS7-C2S4)	Maximum Horsepower						Total Aux. Contacts Installed		cUL Approved- Type 1/12/4/4X IP66	Dimension Code ③
	Single Ø		Three Ø				NO	NC		
	115V	230V	200V	230V	460V	575V			Catalog Number	
	KWIKstarters with Electronic DC Coil ④									
	2	5	~	~	~	~	1	0	CBK7-30E-*-ETD-P▼	Q2
	~	~	7-1/2	10	20	25			CAK7-30E-*-◆-P▼	
	3	5	~	~	~	~	1	0	CBK7-37E-*-ETD-P▼	Q2
	~	~	10	10	25	30			CAK7-37E-*-◆-P▼	
	3	7-1/2	~	~	~	~	1	0	CBK7-43E-*-ETD-P▼	Q2
	~	~	10	15	30	30			CAK7-43E-*-◆-P▼	

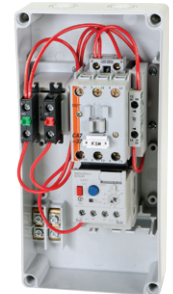

C
KWIKstarters

Replace ◆ with one of the following Overload Relays

For use with KWIKstarter...	Amp Range	Overload Relay Code (◆)	Catalog No. (of Overload Relay used)
3-Phase / Manual Reset / Class 10			
CAK7-30...43	1.0...5.0	D1CD	CEP7-ED1CD
	3.2...16	D1DD	CEP7-ED1DD
	5.4...27	D1ED	CEP7-ED1ED
	9...45	D1FD	CEP7-ED1FD
3-Phase / Auto or Manual Reset / Class 10, 15, 20, 30			
CAK7-30...43	1.0...5.0	ECD	CEP7-EECD
	3.2...16	EDD	CEP7-EEED
	5.4...27	EED	CEP7-EEED
	9...45	EFD	CEP7-EEFD

Pilot Device Options (includes reset) ②⑤

Pushbutton Description	Replace ▼ in catalog number with
START-STOP Multi-function (shown)	3U
I-O Multi-function	4U
OFF-ON 2-Position Selector switch	6
Pilot Light Red (LED) with START-STOP Multi-function	1R3U
Pilot Light Red (LED) with I-O Multi-function	1R4U

Optional CA7 Modifications (Factory Assembled)

Description	Add to end of catalog number
Electronic Interface	-JE
Surge Suppressor RD	-C
Surge Suppressor Varistor	-V
Additional NC Contact	-L01
Additional NO Contact	-L10

Coil Codes ④⑥

D.C. Coil Code	Voltage Range VDC
12E	12V
24E	24V
36E	36-48V
48E	48-72V
110E	110-125V
220E	220-250V

Ordering Instructions

Specify Catalog Number	
Replace (*) with Coil Code	See this page only
Replace (◆) with O/L Relay	
Replace (▼) with Pilot Device Option	

- ❶ Use CEP7-ED/CEP7-EE overloads only. Single-phase applications utilize CEP7S-EEED only.
- ❷ Plastic Bezel is standard. Pilot Device options include D7-BX_ Base Mounted contact blocks. See page H69 for more information.
- ❸ Refer to page C31 for wiring diagram and C34 for dimensional information.
- ❹ CA7-9E...55E with electronic coils are not interchangeable with non-electronic DC or AC coils.
- ❺ One and only one Pilot Device option must be selected.
- ❻ CPT not possible with KS7-C2S4 (Q2) enclosure.

KWIKstarters with CT7N or CEP7 Overload Relays with H-O-A and Light ①②③④⑤⑥

Cover Control/ Enclosure	Maximum Horsepower						Total Aux. Contacts Installed		cUL Approved- Type 1/12/4/4X IP66	Dimen- sion Code ④	
	Single Ø		Three Ø				NO	NC			Catalog Number
	115V	230V	200V	230V	460V	575V					
KWIKstarter with Reset and H-O-A Selector Switch and Light with AC Coil											
	1/2	1 1/2	~	~	~	~	1	0	CBK7-9-✱-◆-P0+1R7 CAK7-9-✱-◆-P0+1R7	Q1	
	~	~	2	2	5	7 1/2					
	1/2	2	~	~	~	~	1	0	CBK7-12-✱-◆-P0+1R7 CAK7-12-✱-◆-P0+1R7	Q1	
	~	~	3	3	7 1/2	10					
	1	3	~	~	~	~	1	0	CBK7-16-✱-◆-P0+1R7 CAK7-16-✱-◆-P0+1R7	Q1	
	~	~	5	5	10	15					
	2	3	~	~	~	~	1	0	CBK7-23-✱-◆-P0+1R7 CAK7-23-✱-◆-P0+1R7	Q1	
	~	~	5	7 1/2	15	15					
	KWIKstarter with Reset and H-O-A Selector Switch and Light with Electronic DC Coil ⑦										
	1/2	1 1/2	~	~	~	~	1	0	CBK7-9E-✱-◆-P0+1R7 CAK7-9E-✱-◆-P0+1R7	Q1	
	~	~	2	2	5	7 1/2					
	1/2	2	~	~	~	~	1	0	CBK7-12E-✱-◆-P0+1R7 CAK7-12E-✱-◆-P0+1R7	Q1	
~	~	3	3	7 1/2	10						
1	3	~	~	~	~	1	0	CBK7-16E-✱-◆-P0+1R7 CAK7-16E-✱-◆-P0+1R7	Q1		
~	~	5	5	10	15						
2	3	~	~	~	~	1	0	CBK7-23E-✱-◆-P0+1R7 CAK7-23E-✱-◆-P0+1R7	Q1		
~	~	5	7 1/2	15	15						

Coil Codes ⑦

A.C. Coil Code	Voltage Range		Control Source	
	50 Hz	60 Hz	CBK7	CAK7
24Z	24V	24V	Separate	Separate
120	110V	120V	Common	Separate
220W	200-220V	208-240V	Common	Common
D.C. Coil Code	Voltage Range			
	VDC			
12E	12V			
24E	24V			

Control Circuit Note

Common: Coils and pilot devices in the control circuit are assumed to be common with the line voltage and will be connected to the line source (L1-L2) per the table.

Separate: Coils and pilot devices in the control circuit are assumed to be from a separate source and will not be connected to the line source per the table. Line Voltage not listed: (i.e.: 480 and 575 VAC) require a separate control source (i.e.: 120 VAC). D7D pilot devices are rated 300 VAC maximum.

Ordering Instructions

Specify Catalog Number	
Replace (✱) with Coil Code Replace (◆) with O/L Relay	See this page See page C30
Important Note: KWIKstarters are only designed to accommodate CT7N Thermal Overload Relays or CEP7 Solid State Overload Relays. Select O/L Relay Code from page C30.	

- ① This is a factory assembly. The KS7-C0S1 (Q1) enclosure does not include knock-outs for field assembly of this starter.
- ② Uses D7D-P4N_ Red Monolithic "Run" pilot light with LED bulb. Pilot light voltage to match coil voltage for 24, 120, 240 VAC control. Red "Run" Light can be changed for Green. Change +1R7 to +1G7. For example, CAK7-9-✱-◆-P0+1R7 becomes CAK7-9-✱-◆-P0+1G7.
- ③ Uses D7D-SM32x20 Monolithic 3-position selector switch for maintain control, HAND-OFF-AUTO function with legend plate.
- ④ Refer to page C32 for wiring and dimensional information. This is a clam-shell enclosure design with wires to cover controls.
- ⑤ Uses CT7N or CEP7-ED/CEP7-EE overload.
- ⑥ One NO auxilliary for customer use. There is no room for additional auxilliaries.
- ⑦ CA7-9E...23E with electronic coils are not interchangeable with non-electronic DC or AC coils.

KWIKstarters with CT7N or CEP7 Overload Relays with I-O Multifunction and E-Stop ①②③④⑤⑥

Cover Control/ Enclosure	Maximum Horsepower						Total Aux. Contacts Installed		cUL Approved-Type 1/12/4/4X IP66	Dimension Code
	Single Ø		Three Ø				NO	NC		
	115V	230V	200V	230V	460V	575V			Catalog Number	
	KWIKstarter with Reset, Multifunction I-O Pushbutton and E-Stop with AC Coil									
	1/2	1 1/2	~	~	~	~	1	0	CBK7-9-*-◆-P0+4U-9	Q1
	~	~	2	2	5	7 1/2			CAK7-9-*-◆-P0+4U-9	
	1/2	2	~	~	~	~	1	0	CBK7-12-*-◆-P0+4U-9	Q1
	~	~	3	3	7 1/2	10			CAK7-12-*-◆-P0+4U-9	
	1	3	~	~	~	~	1	0	CBK7-16-*-◆-P0+4U-9	Q1
	~	~	5	5	10	15			CAK7-16-*-◆-P0+4U-9	
	2	3	~	~	~	~	1	0	CBK7-23-*-◆-P0+4U-9	Q1
	~	~	5	7 1/2	15	15			CAK7-23-*-◆-P0+4U-9	

Coil Codes

A.C. Coil Code	Voltage Range		Control Source	
	50 Hz	60 Hz	CBK7	CAK7
24Z	24V	24V	Separate	Separate
120	110V	120V	Common	Separate
220W	200-220V	208-240V	Common	Common
277	240V	277V	Common	~
415	400-415V	~	~	Common
480	440V	480V	~	Common
600	550V	600V	~	Common

Control Circuit Note

Common: Coils and pilot devices in the control circuit are assumed to be common with the line voltage and will be connected to the line source (L1-L2) per the table.

Separate: Coils and pilot devices in the control circuit are assumed to be from a separate source and will not be connected to the line source per the table. Line Voltage not listed: (i.e.: 480 and 575 VAC) require a separate control source (i.e.: 120 VAC).

Ordering Instructions

Specify Catalog Number	
Replace (*) with Coil Code	See this page See page C30
Replace (◆) with O/L Relay	
Important Note: KWIKstarters are only designed to accommodate CT7N Thermal Overload Relays or CEP7 Solid State Overload Relays. Select O/L Relay Code from page C30.	

- ① This is a factory assembly. The KS7-COS1 (Q1) enclosure does not include knock-outs for field assembly of this starter.
- ② Uses D7P-U2EFFEPX11 Two-Position Multifunction push button with legend I/O.
- ③ Uses D7P-MT44PX01 Emergency Stop Push Button.
- ④ Refer to page C33 for wiring and dimensional information. This is a clam-shell enclosure design with wires to cover controls.
- ⑤ Uses CT7N or CEP7-ED/CEP7-EE overload.
- ⑥ There is no room for additional auxiliaries.

Three Phase Reversing KWIKstarters with CEP7 Overload Relays ①

Enclosure (KS7-COS4R)	Maximum Horsepower				Auxiliary Contacts per Contactor ⑦		cUL Approved-Type 1/12/4/4X IP66	Dimension Code ③
	Three Ø				NO	NC		
	200V	230V	460V	575V			Catalog Number	
	FVR 3-Phase with AC Coil							
	2	2	5	7 1/2	1	1	CAUK7-9-*-*♦-P▼	Q3
	3	3	7 1/2	10	1	1	CAUK7-12-*-*♦-P▼	Q3
	5	5	10	15	1	1	CAUK7-16-*-*♦-P▼	Q3
	5	7 1/2	15	15	1	1	CAUK7-23-*-*♦-P▼	Q3



Coil Codes (*) ④⑥

A.C. Coil Code	Voltage Range		Control Source	
	50 Hz	60 Hz	CBK7	CAK7
24Z	24V	24V	Separate	Separate
120	110V	120V	Common	Separate
220W	200-220V	208-240V	Common	Common
277	240V	277V	Common	~
415	400-415V	~	~	Common
480	440V	480V	~	Common
600	550V	600V	~	Common

Control Circuit Note

Common: Coils and pilot devices in the control circuit are assumed to be common with the line voltage and will be connected to the line source (L1-L2) per the table.

Separate: Coils and pilot devices in the control circuit are assumed to be from a separate source and will not be connected to the line source per the table. Pilot lights are 240 VAC maximum.

Pilot Device Options (includes reset) ②③

Pushbutton Description	Replace ▼ in catalog number with
FOR-STOP-REV Multi-function (shown)	3U
UP-STOP-DOWN Multi-function	4U
OPEN-STOP-CLOSE Multi-function	5U
FOR-STOP-REV 3-Position Selector switch	6
UP-OFF-DOWN 3-Position Selector switch	7
OPEN-OFF-CLOSE 3-Position Selector switch	8
Overload Alarm Pilot Light	1Y
D7-N8 22mm Hole Plug	0

Optional CA7 Modifications (Factory Assembled)

Description (supplied on each contactor)	Add to end of catalog number
Electronic Interface	-2JE
Surge Suppressor RD	-2C
Surge Suppressor Varistor	-2V

Replace ♦ with one of the following Overload Relays

For use with KWIKstarter...	Amp Range	Overload Relay Code (♦)	Catalog Number (of Overload Relay used)
3-Phase / Manual Reset / Class 10			
CAUK7-9...23 CAUK7-9E...23E	0.1...0.5	D1AB	CEP7-ED1AB
	0.2...1.0	D1BB	CEP7-ED1BB
	1.0...5.0	D1CB	CEP7-ED1CB
	3.2...16	D1DB	CEP7-ED1DB
	5.4...27	D1EB	CEP7-ED1EB
3-Phase / Auto or Manual Reset / Class 10, 15, 20, 30			
CAUK7-9...23 CAUK7-9E...23E	0.1...0.5	EAB	CEP7-EEAB
	0.2...1.0	EBB	CEP7-EEBB
	1.0...5.0	ECB	CEP7-EECB
	3.2...16	EDB	CEP7-EEDB
	5.4...27	EEB	CEP7-EEEB

Ordering Instructions

Specify Catalog Number	
Replace (*) with Coil Code	See this page only
Replace (♦) with O/L Relay	
Replace (▼) with Pilot Device Option	

- ① Use CEP7-ED/CEP7-EE overloads only.
- ② Plastic Bezel is standard. Pilot Device options include D7-BX_ Base Mounted contact blocks. See page H69 for more information.
- ③ Refer to page C32 for wiring diagram and C34 for dimensional information.
- ④ Other voltages available, see Section A.
- ⑤ One Pilot Device option must be selected. Blanks are not available. If Pilot Light option is selected then coil voltage must be 24V, 120V or 240V AC only.
- ⑥ CPT not possible with KS7-COS4R (Q3) enclosure.
- ⑦ One N.C. auxiliary contact is used for electrical interlocking. On CAUK7 reversing starters, the N.C. contact comes from the Mechanical/Electrical Interlock unit (Cat# CM7-02).

Three Phase Reversing KWIKstarters with CEP7 Overload Relays ①

Enclosure (KS7-COS4R)	Maximum Horsepower				Auxiliary Contacts per Contactor ⑦		cUL Approved-Type 1/12/4/4X IP66	Dimension Code ③
	Three Ø				NO	NC		
	200V	230V	460V	575V			Catalog Number	
	FVR 3-Phase with Electronic DC Coil							
	2	2	5	7 1/2	1	1	CAUK7-9E-*-*♦-P▼	Q3
	3	3	7 1/2	10	1	1	CAUK7-12E-*-*♦-P▼	Q3
	5	5	10	15	1	1	CAUK7-16E-*-*♦-P▼	Q3
	5	7 1/2	15	15	1	1	CAUK7-23E-*-*♦-P▼	Q3



C
KWIKstarters

Coil Codes ④⑥

D.C. Coil Code	Voltage Range VDC
12E	12V
24E	24V
36E	36-48V
48E	48-72V
110E	110-125V
220E	220-250V

Pilot Device Options (includes reset) ②⑤

Pushbutton Description	Replace ▼ in catalog number with
FOR-STOP-REV Multi-function (shown)	3U
UP-STOP-DOWN Multi-function	4U
OPEN-STOP-CLOSE Multi-function	5U
FOR-STOP-REV 3-Position Selector switch	6
UP-OFF-DOWN 3-Position Selector switch	7
OPEN-OFF-CLOSE 3-Position Selector switch	8
Overload Alarm Pilot Light	1Y
D7-N8 22mm Hole Plug	0

Optional CA7 Modifications (Factory Assembled)

Description (supplied on each contactor)	Add to end of catalog number
Electronic Interface	-2JE
Surge Suppressor RD	-2C
Surge Suppressor Varistor	-2V

Ordering Instructions



Specify Catalog Number	See this page only
Replace (*) with Coil Code	
Replace (♦) with O/L Relay	
Replace (▼) with Pilot Device Option	

Replace ♦ with one of the following Overload Relays

For use with KWIKstarter...	Amp Range	Overload Relay Code (♦)	Catalog Number (of Overload Relay used)
3-Phase / Manual Reset / Class 10			
CAUK7-9...23 CAUK7-9E...23E	0.1...0.5	D1AB	CEP7-ED1AB
	0.2...1.0	D1BB	CEP7-ED1BB
	1.0...5.0	D1CB	CEP7-ED1CB
	3.2...16	D1DB	CEP7-ED1DB
	5.4...27	D1EB	CEP7-ED1EB
3-Phase / Auto or Manual Reset / Class 10, 15, 20, 30			
CAUK7-9...23 CAUK7-9E...23E	0.1...0.5	EAB	CEP7-EEAB
	0.2...1.0	EBB	CEP7-EEBB
	1.0...5.0	ECB	CEP7-EECB
	3.2...16	EDB	CEP7-EEDB
	5.4...27	EEB	CEP7-EEEB

- ① Use CEP7-ED/CEP7-EE overloads only.
- ② Plastic Bezel is standard. Pilot Device options include D7-BX_ Base Mounted contact blocks. See page H69 for more information.
- ③ Refer to page C32 for wiring diagram and C34 for dimensional information.
- ④ CA7-9E...55E with electronic coils are not interchangeable with non-electronic DC or AC coils.
- ⑤ One Pilot Device option must be selected. Blanks are not available. If Pilot Light option is selected then coil voltage must be 24V DC only.
- ⑥ CPT not possible with KS7-COS4R (Q3) enclosure.
- ⑦ One N.C. auxiliary contact is used for electrical interlocking. On CAUK7 reversing starters, the N.C. contact comes from the Mechanical/Electrical Interlock unit (Cat# CM7-02).

NEMA KWIKstarters with CT7N or CEP7 Overload Relays

Cover Control/ Enclosure (KS7-COS1/COS4)	NEMA Size	Maximum Horsepower						Total Aux. Contacts Installed		cUL Approved-Type 1/12/4/4X IP66	Dimension Code
		Single Ø		Three Ø				NO	NC		
		115V	230V	200V	230V	460V	575V			Catalog Number	
KWIKstarter with Start & Raised Stop with AC Coil											
	00	1/3	1	~	~	~	~	1	0	CBKN7-12-*♦-P2 CAKN7-12-*♦-P2	Q1
	0	~	~	1-1/2	1-1/2	2	2	1	0	CBKN7-16-*♦-P2 CAKN7-16-*♦-P2	Q1
	00	1/3	1	~	~	~	~	1	0	CBKN7-12E-*♦-P2 CAKN7-12E-*♦-P2	Q1
	0	~	~	1-1/2	1-1/2	2	2	1	0	CBKN7-16E-*♦-P2 CAKN7-16E-*♦-P2	Q1
KWIKstarter with Reset with AC Coil											
	00	1/3	1	~	~	~	~	1	0	CBKN7-12-*♦-P0 CAKN7-12-*♦-P0	Q1
	0	~	~	1-1/2	1-1/2	2	2	1	0	CBKN7-16-*♦-P0 CAKN7-16-*♦-P0	Q1
	00	1/3	1	~	~	~	~	1	0	CBKN7-12E-*♦-P0 CAKN7-12E-*♦-P0	Q1
	0	~	~	1-1/2	1-1/2	2	2	1	0	CBKN7-16E-*♦-P0 CAKN7-16E-*♦-P0	Q1

This page has moved. See new NEMA Starters Section starting at page 101.1

Coil Codes

A.C. Coil Code	Voltage Range		Source	
	50 Hz	60 Hz	CA7	CAK7
24Z	24V	24V	Separate	Separate
120	110V	120V	Common	Separate
208	~	208V	~	Common
220W	208V-220V	208V-240V	Common	Common
240	220V	240V	Common	Common
277	240V	277V	Common	~
380	380V-400V	440V	~	Common
480	440V	480V	~	Common
600	550V	600V	~	Common
D.C. Coil Code	Voltage Range			
	VDC			
12E	12V			
24E	24V			

Control Circuit Note

Common: Coils are assumed to be common with the line voltage and will be connected to the line source (L1-L2) per the table.

Separate: Coils are assumed to be from a separate source and will not be connected to the line source per the table.

Ordering Instructions

Specify Catalog Number	
Replace (*) with Coil Code	See this page
Replace (♦) with O/L Relay	See page C30
Important Note: KWIKstarters are only designed to accommodate CT7N Thermal Overload Relays or CEP7 Solid State Overload Relays. Select O/L Relay Code from page C30.	

- ① KWIKstarters are designed for three-wire control circuits. Two-wire (maintain) control can be accomplished by adding pushbutton latch KS7-PLA.
- ② A special design NO auxiliary contact (Cat.# KS7-PCK) is used as the holding circuit interlock, as well as, the START button interface. It is not available for other use.
- ③ Refer to page C33 for dimensional information.
- ④ STOP button also functions as RESET button. Plastic Bezel is standard.
- ⑤ Other voltages available, see Section A.
- ⑥ Use CT7N or CEP7-ED/CEP7-EE overload.
- ⑦ CAN7-12E...16E with electronic coils are not interchangeable with non-electronic DC or AC coils.

NEMA KWIKstarters with CT7N or CEP7 Overload Relays with H-O-A and Light

Cover Control/Enclosure (KS7-COS1)	NEMA Size	Maximum Horsepower						Total Aux. Contacts Installed		cUL Approved-Type 1/12/4/4X IP66	Dimension Code
		Single Ø		Three Ø				NO	NC		
		115V	230V	200V	230V	460V	575V			Catalog Number	
	NEMA KWIKstarter with Reset and H-O-A Selector Switch and Light with AC Coil										
	00	1/3	1	~	~	~	~	1 ⑥	0	CBKN7-12-*-◆-P0+1R7	Q1
		~	~	1-1/2	1-1/2	2	2			CAKN7-12-*-◆-P0+1R7	
	0	1	2	~	~	~	~	1 ⑥	0	CBKN7-16-*-◆-P0+1R7	Q1
		~	~	3	3	5	5			CAKN7-16-*-◆-P0+1R7	
	NEMA KWIKstarter with Reset and H-O-A Selector Switch and Light with Electronic DC Coil ⑦										
	00	1/3	1	~	~	~	~	1 ⑥	0	CBKN7-12E-*-◆-P0+1R7	Q1
		~	~	1-1/2	1-1/2	2	2			CAKN7-12E-*-◆-P0+1R7	
	0	1	2	~	~	~	~	1 ⑥	0	CBKN7-16E-*-◆-P0+1R7	Q1
		~	~	3	3	5	5			CAKN7-16E-*-◆-P0+1R7	

This page has moved. See new NEMA Starters Section starting at page 101.1

Coil Codes ⑦

A.C. Coil Code	Voltage Range		Common	CAK7
	50 Hz	60 Hz		
24Z	24V	24V	Separate	Separate
120	110V	120V	Common	Separate
208	208V	208V	~	Common
240	208V-240V	208V-240V	Common	Common
24E	220V	240V	Common	Common

D.C. Coil Code	Voltage Range	
	VDC	
12E	12V	
24E	24V	

Control Circuit Note

Common: Coils and pilot devices in the control circuit are assumed to be common with the line voltage and will be connected to the line source (L1-L2) per the table.

Separate: Coils and pilot devices in the control circuit are assumed to be from a separate source and will not be connected to the line source per the table. Line Voltage not listed: (i.e.: 480 and 575 VAC) require a separate control source (i.e.: 120 VAC). D7D pilot devices are rated 300 VAC maximum.

Ordering Instructions

Specify Catalog Number	
Replace (*) with Coil Code	See this page See page C30
Replace (◆) with O/L Relay	
Important Note: KWIKstarters are only designed to accommodate CT7N Thermal Overload Relays or CEP7 Solid State Overload Relays. Select O/L Relay Code from page C30.	

- ① This is a factory assembly. The KS7-COS1 (Q1) enclosure does not include knock-outs for field assembly of this starter.
- ② Uses D7D-P4N Red Monolithic "Run" pilot light with LED bulb. Pilot light voltage to match coil voltage for 24, 120, 240 VAC control. Red "Run" Light can be changed for Green. Change +1R7 to +1G7. For example, CAKN7-9-*-◆-P0+1R7 becomes CAKN7-9-*-◆-P0+1G7.
- ③ Uses D7D-SM32x20 Monolithic 3-position selector switch for maintain control, HAND-OFF-AUTO function with legend plate.
- ④ Refer to page C32 for wiring and dimensional information. This is a clam-shell enclosure design with wires to cover controls.
- ⑤ Uses CT7N or CEP7-ED/CEP7-EE overload.
- ⑥ One NO auxilliary for customer use. There is no room for additional auxilliaries.
- ⑦ CAN7-12E...16E with electronic coils are not interchangeable with non-electronic DC or AC coils.

NEMA KWIKstarters with CEP7 Overload Relays ①

Enclosure (KS7-C2S4)	NEMA Size	Maximum Horsepower						Total Aux. Contacts Installed		cUL Approved-Type 1/12/4/4X IP66	Dimension Code
		Single Ø		Three Ø				NO	NC		
		115V	230V	200V	230V	460V	575V			Catalog Number	
	NEMA KWIKstarters with AC Coil										
	1	2	3	~	~	~	~	1	0	CBKN7-37-*-ETD-P▼	Q2
		~	~	7-1/2	7-1/2	10	10			CAKN7-37-*-♦-P▼	
	2	3	7-1/2	~	~	~	~	1	0	CBKN7-43-*-ETD-P▼	Q2
		~	~	10	15	25	25			CAKN7-43-*-♦-P▼	
	NEMA KWIKstarters with Electronic DC Coil ④										
	1	3	5	~	~	~	~	1	0	CBKN7-37E-*-ETD-P▼	Q2
		~	~	10	10	25	30			CAKN7-37E-*-♦-P▼	
	2	3	7-1/2	~	~	~	~	1	0	CBKN7-43E-*-ETD-P▼	Q2
		~	~	10	15	30	30			CAKN7-43E-*-♦-P▼	

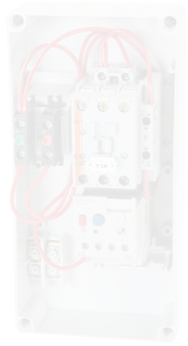

Coil Codes (*) ④⑤⑦

A.C. Coil Code	Voltage Range		Control Source		D.C. Coil Code	Voltage Range VDC
	50 Hz	60 Hz	CBK7	CAK7		
24Z	24V	24V	Separate	Separate	12E	12V
120	110V	120V	Common	Separate	24E	24V
208	~	208V	~	Common	36E	36V
220W	200V-220V	208V-240V	Common	Common	48E	48-72V
240	220V	240V	Common	Common	220E	220V
277	240V	277V	Common	Common	250E	250V
380	380V-400V	440V	~	Common		
480	440V	480V	~	Common		
600	550V	600V	~	Common		

AC Control Circuit Note

Common: Coils and pilot devices in the control circuit are assumed to be common with the line voltage and will be connected to the common terminal of the coil per the table.
Separate: Coils and pilot devices in the control circuit are assumed to be from a separate source and will not be connected to the line source per the table. Pilot lights are 240 VAC maximum.

This page has moved. See new NEMA Starters Section starting at page 101.1

Replace one of the following Overload Relays

For use with KWIKstarter...	Amp Range	Overload Relay Code (♦)	Catalog Number (of Overload Relay used)
3-Phase / Manual Reset / Class 10			
CAK7-30...43	1.0...5.0	D1CD	CEP7-ED1CD
	3.2...16	D1DD	CEP7-ED1DD
	5.4...27	D1ED	CEP7-ED1ED
	9...45	D1FD	CEP7-ED1FD
3-Phase / Auto or Manual Reset / Class 10, 15, 20, 30			
CAK7-30...43	1.0...5.0	ECD	CEP7-EECD
	3.2...16	EDD	CEP7-EEDD
	5.4...27	EED	CEP7-EEED
	9...45	EFD	CEP7-EEFD

Pilot Device Options (includes reset) ②⑥

Pushbutton Description	Replace ▼ in catalog number with
START-STOP Multi-function (shown)	3U
I-O Multi-function	4U
OFF-ON 2-Position Selector switch	6
Pilot Light Red (LED) with START-STOP Multi-function	1R3U
Pilot Light Red (LED) with I-O Multi-function	1R4U

Optional CA7 Modifications (Factory Assembled)

Description	Add to end of catalog number
Electronic Interface	-JE
Surge Suppressor RD	-C
Surge Suppressor Varistor	-V
Additional NC Contact	-L01
Additional NO Contact	-L10

Ordering Instructions

Specify Catalog Number	
Replace (*) with Coil Code	See this page only
Replace (♦) with O/L Relay	
Replace (▼) with Pilot Device Option	

- ① Use CEP7-ED/CEP7-EE overloads only. Single-phase applications utilize CEP7S-EETD only.
- ② Plastic Bezel is standard. Pilot Device options include D7-BX_ Base Mounted contact blocks. See page H69 for more information.
- ③ Refer to page C31 for wiring diagram and C34 for dimensional information.
- ④ CAN7-37E...43E with electronic coils are not interchangeable with non-electronic DC or AC coils.

- ⑤ Other voltages available, see Section A.
- ⑥ One - and only one Pilot Device option must be selected. If Pilot Light option is selected then coil voltage must be 24V AC or DC, 120V or 240V AC only.
- ⑦ CPT not possible with KS7-C2S4 (Q2) enclosure.

Three Phase Reversing NEMA KWIKstarters with CEP7 Overload Relays ①

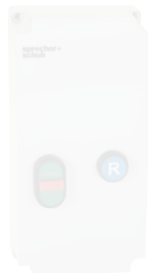
Enclosure (KS7-COS4R)	NEMA Size	Maximum Horsepower				Total Aux. Contacts Installed		cUL Approved-Type 1/12/4/4X IP66	Dimension Code
		Three Ø				NO	NC		
		200V	230V	460V	575V			Catalog Number	
	3-Phase FVR NEMA KWIKstarter with AC Coil								
	00	1-1/2	1-1/2	2	2	1	1	CAUKN7-12-*♦-P▼	Q3
	0	3	3	5	5	1	1	CAUKN7-16-*♦-P▼	Q3
	3-Phase FVR NEMA KWIKstarter with Electronic DC Coil								
	00	1-1/2	1-1/2	2	2	1	1	CAUKN7-12E-*♦-P▼	Q3
	0	3	3	5	5	1	1	CAUKN7-16E-*♦-P▼	Q3



KWIKstarters

Coil Codes (*) ④⑤⑦

A.C. Coil Code	Voltage Range		Control Source		D.C. Coil Code	Voltage Range VDC
	50 Hz	60 Hz	CBK7	CAK7		
24Z	24V	24V	Separate	Separate	12E	12V
120	110V	120V	Common	Separate	24E	24V
220W	200-220V	208-240V	Common	Common	48E	48V
277	240V	277V	Common	~	220E	220V
415	400-415V	~	~	Common	~	~
480	440V	480V	~	~	~	~
600	550V	600V	~	~	~	~

AC Control Circuit Note

Common: Coils and pilot devices in the control circuit are assumed to be common with the line voltage source and will be connected to the line source (L1-L2) per the table. Separate coils and pilot devices in the control circuit are assumed to be from a separate source and will not be connected to the line source. Pilot lights are 240 VAC maximum.

This page has moved. See new NEMA Starters Section starting at page 101.1

Pilot Device Options (if used) ②③

Push Button Description	Replace in catalog number with
FOR-STOP-REV Multi-function (shown)	3U
UP-STOP-DOWN Multi-function	4U
OPEN-STOP-CLOSE Multi-function	5U
FOR-STOP-REV 3-Position Selector switch	6
UP-OFF-DOWN 3-Position Selector switch	7
OPEN-OFF-CLOSE 3-Position Selector switch	8
Overload Alarm Pilot Light	1Y
D7-N8 22mm Hole Plug	0

Optional CA7 Modifications (Factory Assembled)

Description (supplied on each contactor)	Add to end of catalog number
Electronic Interface	-2JE
Surge Suppressor RD	-2C
Surge Suppressor Varistor	-2V

Ordering Instructions



Specify Catalog Number	See this page only
Replace (*) with Coil Code	
Replace (♦) with O/L Relay	
Replace (▼) with Pilot Device Option	

Replace ♦ with one of the following Overload Relays



For use with KWIKstarter...	Amp Range	Overload Relay Code (♦)	Catalog Number (of Overload Relay used)	
3-Phase / Manual Reset / Class 10				
CAUKN7-12..16 CAUKN7-12E..16E	0.1...0.5	D1AB	CEP7-ED1AB	
	0.2...1.0	D1BB	CEP7-ED1BB	
	1.0...5.0	D1CB	CEP7-ED1CB	
	3.2...16	D1DB	CEP7-ED1DB	
CAUKN7-12..16 CAUKN7-12E..16E	5.4...27	D1EB	CEP7-ED1EB	
	3-Phase / Auto or Manual Reset / Class 10, 15, 20, 30			
	0.1...0.5	EAB	CEP7-EEAB	
	0.2...1.0	EBB	CEP7-EEBB	
CAUKN7-12..16 CAUKN7-12E..16E	1.0...5.0	ECB	CEP7-EECB	
	3.2...16	EDB	CEP7-EEDB	
	5.4...27	EEB	CEP7-EEEB	

- ① Use CEP7-ED/CEP7-EE overloads only.
- ② Plastic Bezel is standard. Pilot Device options include D7-BX_ Base Mounted contact blocks. See page H69 for more information.
- ③ Refer to page C32 for wiring diagram and C34 for dimensional information.
- ④ CAN7-12E...16E with electronic coils are not interchangeable with non-electronic DC or AC coils.
- ⑤ Other voltages available, see Section A.
- ⑥ One Pilot Device option must be selected. Blanks are not available. If Pilot Light option is selected then Pilot Light must match Coil Voltage 24V AC or DC, 120V or 240V AC only.
- ⑦ CPT not possible with KS7-COS4R (Q3) enclosure.
- ⑧ One N.C. auxiliary contact is used for electrical interlocking. On CAUKN7 reversing starters, the N.C. contact comes from the Mechanical/Electrical Interlock unit (Cat# CM7-02).

KWIKstarter 9...23A Enclosures with CT7N or CEP7 Overload Relays ①②

Component	Description	For Use With		Environmental Approvals	Catalog Number
		Contactors	Overload		
	Flush Green START / Extended Red STOP - Mechanical interface auxiliary contact (KS7-PCK) included in enclosure.	CA7-9...23	CT7N CEP7-1__B ③	cUL Type 1/12/4/4x IEC IP66	KS7-COS4
	Blue RESET Only	CA7-9...23	CT7N CEP7-1__B ③	cUL Type 1/12/4/4x IEC IP66	KS7-COS1



KWIKstarter Enclosures for use with CA7 Contactors and Overload Relays ①⑤

Component	Description	For Use With		Environmental Approvals	Catalog Number
		Contactors	Overload		
	Enclosure for KWIKstarter ③ CAK7/CBK7-30...43 CAK7/CBK7-30E...43E	CA7-30...43 CA7-30E...43E	CEP7-1__D ⑥	cUL Type 1/12/4/4x IEC IP66	KS7-C2S4
	Enclosure for Reversing KWIKstarter ④ CAUK7-9...23 CAUK7-9E...23E	CAU7-9...23 CAU7-9E...23E	CEP7-1__B ③	cUL Type 1/12/4/4x IEC IP66	KS7-COS4R

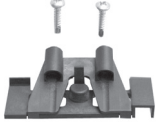

- ① KWIKstarters are only designed to accommodate CA7-9...43 contactors with CT7N Thermal Overload Relays or CEP7 Solid State Overload Relays. If ordering components, select contactor from Section A and overload relay from Section B in this catalog.
- ② KS7-COS4 and KS7-COS1 may be used with either CEP7 or CT7N (field interchangeable).
- ③ KWIKstarter enclosure KS7-C2S4 are designed to fit CA7-30(E)...43(E) contactors with CEP7 Overload Relays. CT7N Thermal Overloads can not be substituted.

- ④ KWIKstarter enclosure KS7-COS4R are designed to fit CAU7-9(E)...23(E) reversing contactors with CEP7 Overload Relays. CT7N Thermal Overloads can not be substituted.
- ⑤ KS7-C2S4 and KS7-COS4R are supplied with two 22mm holes for Pilot Devices. A Reset is required and one additional pilot device kit from page C29 must be selected. Use of a CPT is not possible.
- ⑥ KS7-C_ Series B enclosures are compatible to 3rd gen CEP7-1. KS7-C_ Series A enclosures (obsolete) are compatible to 2nd gen CEP7-ED1/EE.

KWIKstarter Components with CT7N or CEP7 Overload Relays (for use with KS7-COS1/KS7-COS4)

Component	Description	For Use With...	Catalog Number
	Start - Contact kit Specially designed NO auxiliary; mechanically interfaces with the START button. Mounts on right side. A KS7-PCK is included in every KS7-COS4 enclosure.	KS7-COS4 (Replacement Part)	KS7-PCK
	Pushbutton Latch - For maintain contact control (2-wire control)	KS7-COS4	KS7-PLA
	Neutral Terminal	KS7-COS1 KS7-COS4	KS7-PNT
	Grounding Kit (for use with metal conduit)	All KWIKstarter enclosures	KS7-GR1

KWIKstarter Pilot Device Kits (for use with KS7-C2S4/KS7-COS4R) ❶

Kits	Description	For Use With Enclosure...	Contact Blocks included		Catalog Number
			NO	NC	
	Multi-Function Pushbutton kit Non-illuminated START-STOP I-O	KS7-C2S4 Type 1, 12, 4, 4X	1	1	KS7-P3U KS7-P4U
	FOR-STOP-REV UP-STOP-DOWN OPEN-STOP-CLOSE	KS7-COS4R Type 1, 12, 4, 4X	2	1	KS7-P3U-REV KS7-P4U-REV KS7-P5U-REV
	Selector switch kits Non-illuminated, includes legend plate ON-OFF 2-Position	KS7-C2S4 Type 1, 12, 4, 4X	1	-	KS7-P6
	FOR-OFF-REV 3-Position UP-OFF-DOWN 3-Position OPEN-OFF-CLOSE 3-Position	KS7-COS4R Type 1, 12, 4, 4X	2	-	KS7-P6-REV KS7-P7-REV KS7-P8-REV
	Reset Pushbutton, Blue Plastic push button, flush operator with Blue Cap and R text	KS7-C2S4 KS7-COS4	Black Plastic with Blue Cap and White "R"		D7P-F611 ❷

❶ Plastic bezel is standard. Pilot Device Kits include D7-BX_ Base Mounted contact blocks. See page H69 for more information.

❷ D7P-R611 and CEP7-ERA can not be used with KS7-C2S4 or KS7-COS4R. See Section H for more information.

**KWIKstarters with CEP7 Solid State Overload Relay
3-Phase Application ②③**

For use with KWIKstarter...	Amp Range	Overload Relay Code (◆)	Catalog Number (of Overload Relay used)
3-Phase / Manual Reset / Class 10			
CAK7-9...CAK7-23	0.1...0.5	D1AB	CEP7-ED1AB
	0.2...1.0	D1BB	CEP7-ED1BB
	1.0...5.0	D1CB	CEP7-ED1CB
	3.2...16	D1DB	CEP7-ED1DB
	5.4...27	D1EB	CEP7-ED1EB
3-Phase / Selectable Function and Class			
CAK7-9...CAK7-23	0.1...0.5	EAB	CEP7-EEAB
	0.2...1.0	EBB	CEP7-EEBB
	1.0...5.0	ECB	CEP7-EECB
	3.2...16	EDB	CEP7-EEDB
	5.4...27	EEB	CEP7-EEEB

**KWIKstarters with CEP7 Solid State Overload Relay
1-Phase Application ②③**

For use with KWIKstarter...	Amp Range	Overload Relay Code (◆)	Catalog Number (of Overload Relay used)
1-Phase / Selectable Function and Class			
CBK7-9...CBK7-23	1.0-5.0	EPB	CEP7S-EEPB
	3.2-16	ERB	CEP7S-EERB
	5.4-27	ESB	CEP7S-EESB

**KWIKstarters with CT7N Bimetallic
Overload Relays ①**

For use with Kwikstarter...	Amp Range	Overload Relay Code (◆)	Catalog Number (of Overload Relay used)
CAK7-9...CAK7-23 and CBK7-9...CBK7-23 Frame "A"	0.10...0.16	AA16	CT7N-23-A16
	0.16...0.25	AA25	CT7N-23-A25
	0.25...0.40	AA40	CT7N-23-A40
	0.35...0.50	AA50	CT7N-23-A50
	0.45...0.63	AA63	CT7N-23-A63
	0.55...0.80	AA80	CT7N-23-A80
	0.75...1.0	AB10	CT7N-23-B10
	0.90...1.3	AB13	CT7N-23-B13
	1.1...1.6	AB16	CT7N-23-B16
	1.4...2.0	AB20	CT7N-23-B20
	1.8...2.5	AB25	CT7N-23-B25
	2.3...3.2	AB32	CT7N-23-B32
	2.9...4.0	AB40	CT7N-23-B40
	3.5...4.8	AB48	CT7N-23-B48
	4.5...6.3	AB63	CT7N-23-B63
	5.5...7.5	AB75	CT7N-23-B75
	7.2...10	AC10	CT7N-23-C10
	9.0...12.5	AC12	CT7N-23-C12
	11.3...16	AC16	CT7N-23-C16
	15...20	AC20	CT7N-23-C20
17.5...21.5	AC21	CT7N-23-C21	
21...25	AC25	CT7N-23-C25	

- ① If using CT7N in single phase application with CBK7-9...23, wire per drawing on page C31.
- ② CEP7 Overloads are available for use in KWIKstarters if the premium features are required (see Section B).
- ③ 3-phase CEP7-ED or CEP7-EE units are only designed for 3□ applications. Single phase CEP7S units are only designed for 1□ applications. If using CEP7S, wire per drawing on page C31.

KWIKstarter (in enclosure KS7-COS1/COS4)

CUSTOMER MUST PROVIDE PROPER BRANCH CIRCUIT PROTECTION (F1)
SEE THE APPLICATION INSTRUCTION SHEET - COMPONENT SELECTION TABLES
FOR MAX. FUSE SIZE & CLASS AND APPLICABLE SHORT CIRCUIT RATING
(USE 75°C COPPER WIRE ONLY)

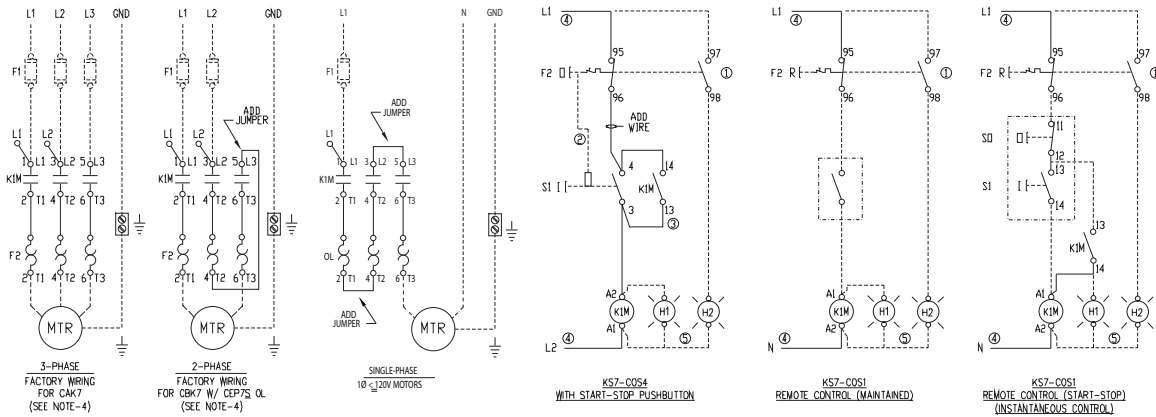

THIS DRAWING IS FOR THE FOLLOWING ENCLOSURES:
KS7-COS4 with integrated START-STOP push buttons
KS7-COS1 with integrated RESET push button

NOTES:

- 1) MECHANICAL LATCH KS7-PLA FOR MAINTAINED CONTROL (OPTIONAL).
- 2) START CONTACT KIT KS7-PCK (INCLUDED) MOUNTS ON THE RIGHT SIDE WITH MOLDED PRE-FORMED JUMPERS.
- 3) DO NOT WIRE CONTROLS CIRCUIT TO LINE SIDE OF CONTACTOR WHEN COIL VOLTAGE IS 120V OR LESS. (FACTORY WIRING STANDARD)
- 4) OPTIONAL PILOT LIGHTS.

KWIKstarter (in enclosure KS7-C2S4)

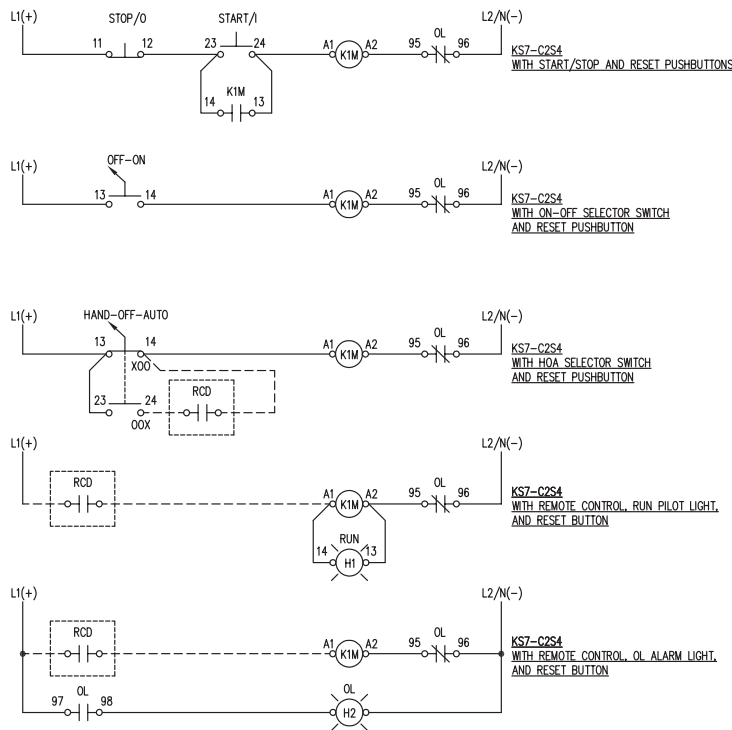

CUSTOMER WILL PROVIDE BRANCH CIRCUIT PROTECTION (F1)
SEE THE APPLICATION INSTRUCTION SHEET - COMPONENT SELECTION TABLES
FOR MAX. FUSE SIZE, CLASS, AND APPLICABLE SHORT CIRCUIT RATING
(USE 75°C COPPER WIRE ONLY)

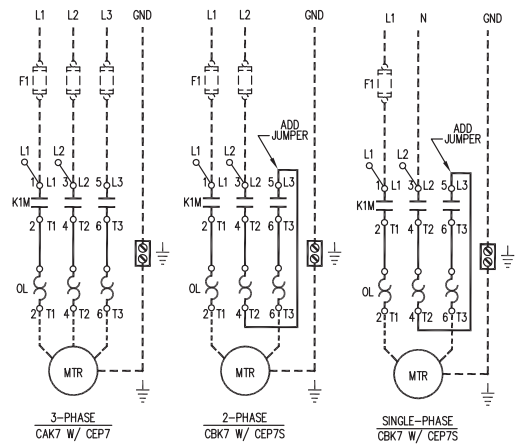

NOTES:

1. DO NOT CONNECT A1-A2 TO L1-L2 UNLESS COIL VOLTAGE MATCHES LINE VOLTAGE
2. PILOT LIGHTS POSSIBLE FOR REMOTE OR OVERLOAD ALARM IF NO START/STOP CONTROL DEVICES IN COVER
3. RCD = REMOTE CONTROL DEVICE (BY OTHERS)

Reversing KWIKstarter (in enclosure KS7-C0S4R)

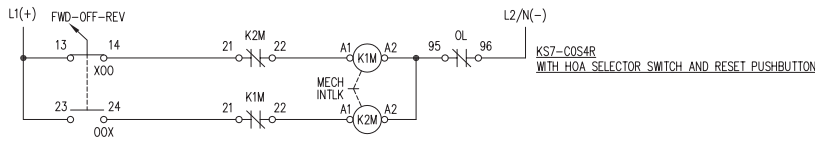
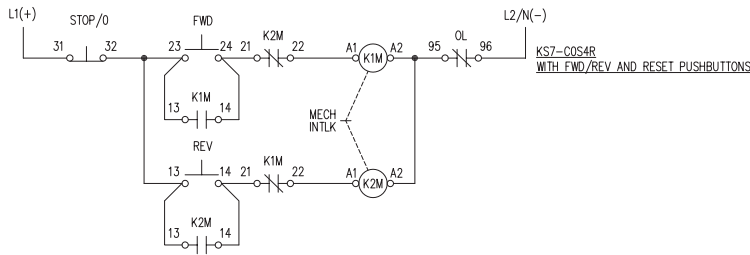

NOTE:
DO NOT CONNECT A1-A2 TO L1-L2 UNLESS COIL VOLTAGE MATCHES LINE VOLTAGE

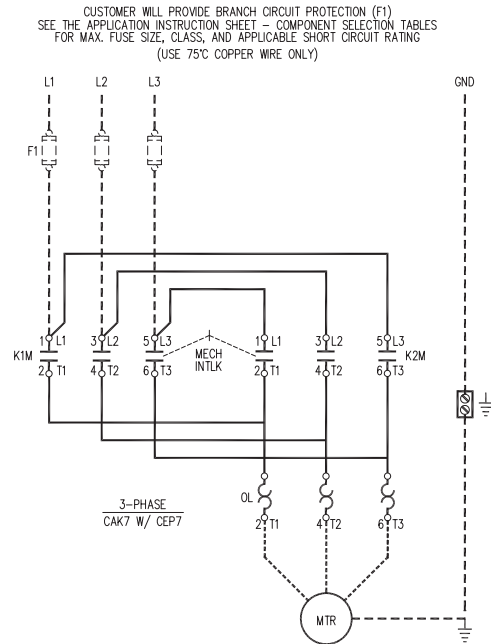

KWIKstarter (in enclosure KS7-C0S1) with HOA option

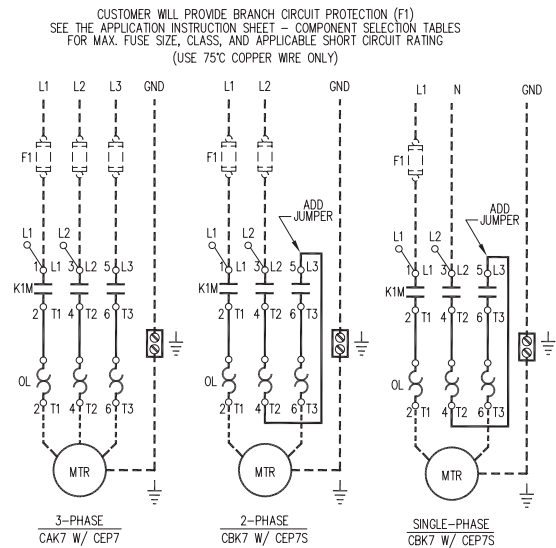
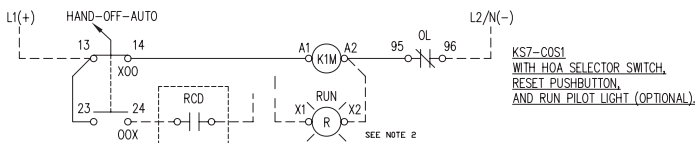
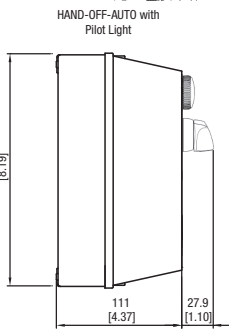

NOTES:

- RCD = REMOTE CONTROL DEVICE (BY OTHERS). WIRE RCD TO TERMINAL 24 ON THE H-O-A SEL. SW. AND TERMINAL A1 ON THE CONTACTOR.
- DASHED LINES ----- INDICATE WIRING PROVIDED IN THE FIELD.

A.C. Coil Code	Voltage Range		Control Source	
	50 Hz	60 Hz	CBK7	CAK7
24Z	24V	24V	Separate	Separate
120	110V	120V	Common	Separate
208	~	208V	~	Common
220W	200V-220V	208V-240V	Common	Common
240	220V	240V	Common	Common
D.C. Coil Code	Voltage Range		Control Source	
	VDC		CBK7	CAK7
12E	12V		Separate	Separate
24E	24V		Separate	Separate

KWIKstarter (in enclosure KS7-COS1) with Emergency Stop option

EMERGENCY STOP with MULTI-FUNCTION

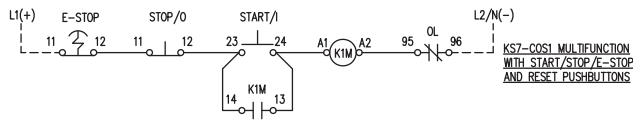
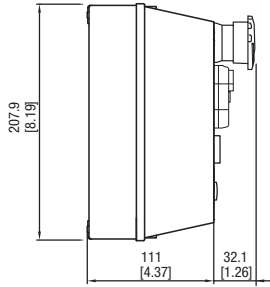

A.C. Coil Code	Voltage Range		Control Source	
	50 Hz	60 Hz	CBK7	CAK7
24Z	24V	24V	Separate	Separate
120	110V	120V	Common	Separate
208	~	208V	~	Common
220W	200V-220V	208V-240V	Common	Common
240	220V	240V	Common	Common

CUSTOMER WILL PROVIDE BRANCH CIRCUIT PROTECTION (F1)
SEE THE APPLICATION INSTRUCTION SHEET - COMPONENT SELECTION TABLES
FOR MAX. FUSE SIZE, CLASS, AND APPLICABLE SHORT CIRCUIT RATING
(USE 75°C COPPER WIRE ONLY)

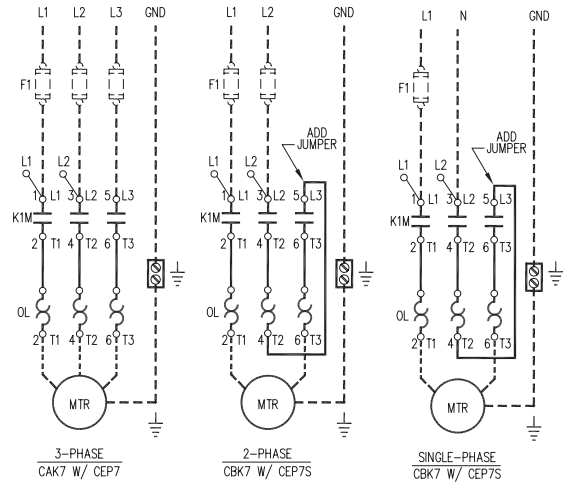

KWIKstarter Enclosure KS7-COS1/COS4 (Dimension Code Q1)

Dimensions are in millimeters (inches). Dimensions not intended for manufacturing purposes.

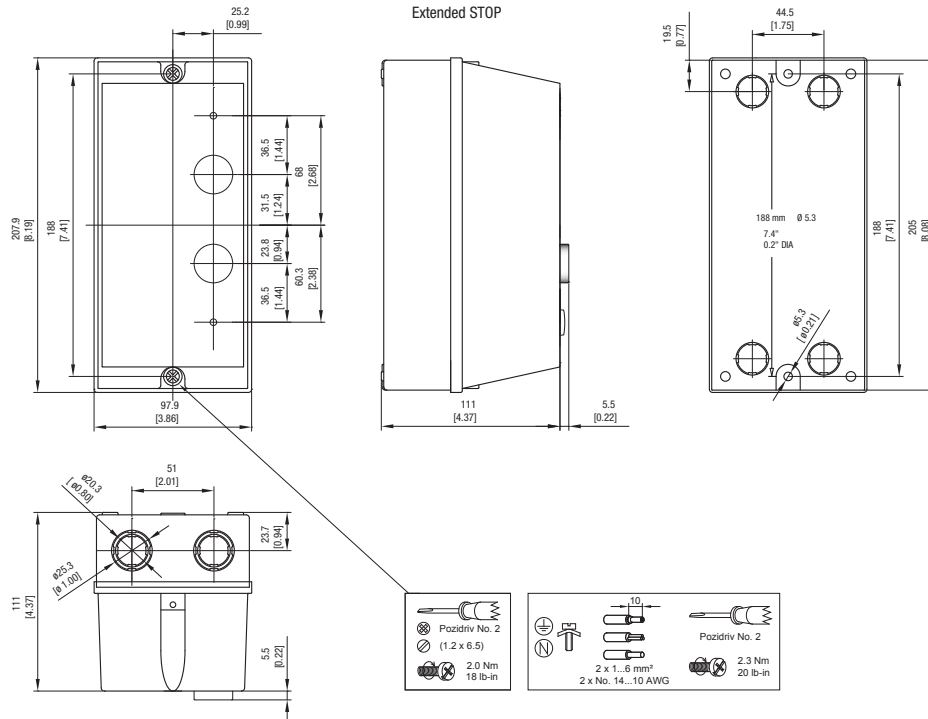

KWIKstarter Enclosure KS7-C2S4 (Dimension Code Q2)

Dimensions are in millimeters (inches). Dimensions not intended for manufacturing purposes.

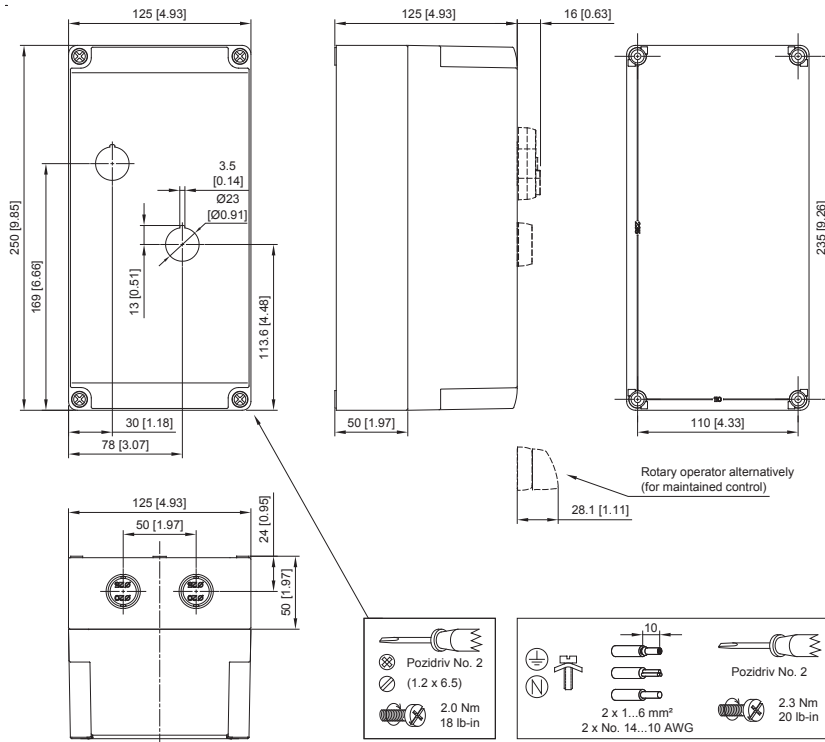

KWIKstarter Enclosure KS7-C0S4R (Dimension Code Q3)

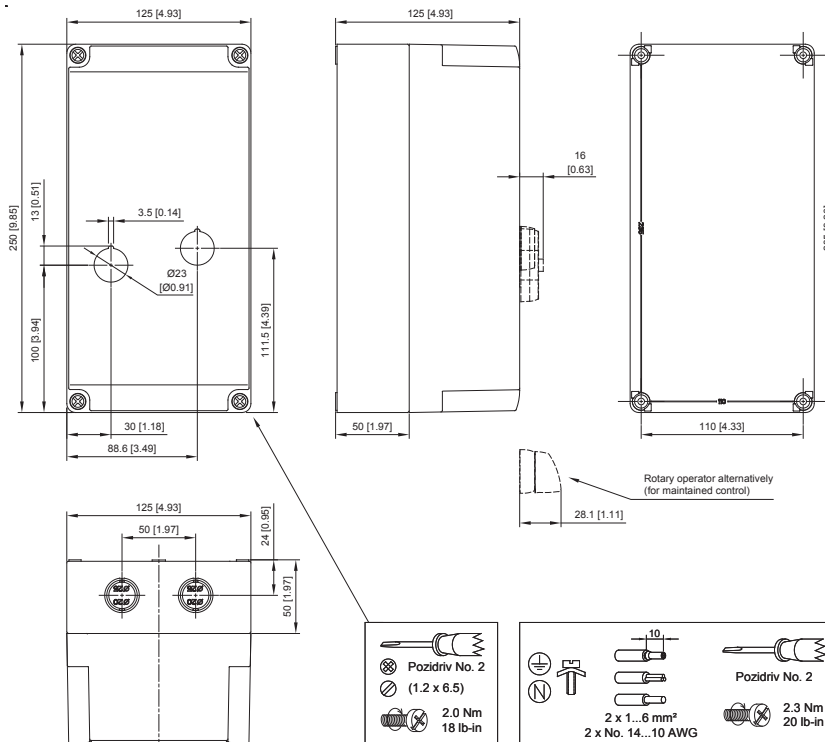

Enclosed Contactors

Sprecher + Schuh's popular contactor lines housed in a variety of enclosures

Sprecher + Schuh's broad line of IEC/UL HP rated contactors can be purchased pre-installed in a variety of standard enclosures. Cataloged enclosures include:

Type 1	General Purpose
Type 12	Industrial Dusttight
Type 3R	Raintight (outdoor)
Type 4	Watertight
Type 4X	Watertight, Corrosion Resistant Non-Metallic

Even though these are the most popular enclosure types for most industrial applications, we can house any contactor in a custom enclosure of your choice.

Quality enclosures ensure the highest confidence



Sprecher + Schuh only sources enclosures from name brand manufacturers, ensuring the highest quality. We primarily use enclosures that meet UL Standards, i.e., Type 1, Type 3R, etc., however, we can also source IEC-type enclosures at your request. Enclosures are sized first to accommodate the depth of the contactor and offer sufficient electrical clearances to satisfy UL.

Add a variety of modifications

If you need a larger enclosure than what is specified in our catalog, your sales representative and our Engineering department will work with you to customize any of our enclosed products to suit your exact specifications. Any combination of enclosure types, sizes, pilot devices, meters and other modifications can be combined to provide exactly the panel you need.



Precisely match the contactor to the application

Unique to IEC-style contactors is the ability to select the exact device required for a specific application. By identifying the conditions under which the contactor will be used, i.e., resistive loads, reversing, inching and plugging, etc., published "life-curve" data predicts contact life in millions of operations. This information enables you to select the precise contactor for your application... without buying too much or too little. Refer to Section A in this catalog for detailed technical information on all Sprecher + Schuh contactors.

Other unique features...

Virtually all Sprecher+Schuh contactors offer one or more of the latest design techniques and innovations, such as electronically controlled coils, field installable auxiliary contacts or universal accessories across the entire contactor family.



Type 1



Type 3R



Type 4



Type 4X

C

Enclosed Contactors

Three Phase, Non-Reversing CA7 & CA9

Continuous Amp Rating - UL/CSA -	Maximum Horsepower Three Phase				Auxiliary Contacts per Contactor ③		Type 1 General Purpose	DIM	Type 12 [Type 3R ④] Industrial Dusttight	DIM
	Enclosed	200V	230V	460V	575V	NO	NC		Catalog Number	
25	2	2	5	7.5	1	0	CA7-9-*-G0	A	CA7-9-*-D0	L
25	3	3	7.5	10	1	0	CA7-12-*-G0	A	CA7-12-*-D0	L
30	5	5	10	15	1	0	CA7-16-*-G0	A	CA7-16-*-D0	L
30	5	7.5	15	15	1	0	CA7-23-*-G0	A	CA7-23-*-D0	L
55	7.5	10	20	25	1	0	CA7-30-*-G0	A	CA7-30-*-D0	L
60	10	10	25	30	1	0	CA7-37-*-G0	A	CA7-37-*-D0	L
75	10	15	30	30	1	0	CA7-43-*-G0	A	CA7-43-*-D0	L
75	15	20	40	40	1	0	CA7-55-*-G0	A	CA7-55-*-D0	L
90	15	20	40	50	1	0	CA7-60-*-G0	B	CA7-60-*-D0	M
90	20	25	50	60	1	0	CA7-72-*-G0	B	CA7-72-*-D0	M
100	25	30	60	60	1	0	CA7-85-*-G0	B	CA7-85-*-D0	M
120	30	30	75	75	1	0	CA7-97-*-G0	B	CA7-97-*-D0	O
116	30	40	75	100	1	1	CA9-116-*-G0 ④	E	CA9-116-*-D0 ④	Q
146	40	50	100	125	1	1	CA9-146-*-G0 ④	E	CA9-146-*-D0 ④	Q
190	50	60	125	150	1	1	CA9-190-*-G0 ④	E	CA9-190-*-D0 ④	R
205	60	75	150	200	1	1	CA9-205-*-G0 ④	F	CA9-205-*-D0 ④	T
265	75	100	200	250	1	1	CA9-265-*-G0 ④	F	CA9-265-*-D0 ④	T
305	100	125	250	300	1	1	CA9-305-*-G0 ④	H	CA9-305-*-D0 ④	H
370	125	150	300	350	1	1	CA9-370-*-G0 ④	H	CA9-370-*-D0 ④	H
400	125	150	350	400	1	1	CA9-400-EI-*-G0	R/F	CA9-400-EI-*-D0	R/F
460	150	200	400	500	1	1	CA9-460-EI-*-G0	R/F	CA9-460-EI-*-D0	R/F
480	200	250	500	600	1	1	CA9-580-EI-*-G0	R/F	CA9-580-EI-*-D0	R/F
750	250	300	600	700	1	1	CA9-750-EI-*-G0	R/F	CA9-750-EI-*-D0	R/F
860	~	400	800	1000	1	1	CA9-860-EI-*-G0	R/F	CA9-860-EI-*-D0	R/F
1060	~	450	900	1150	1	1	CA9-1060-EI-*-G0	R/F	CA9-1060-EI-*-D0	R/F

NOTE: Catalog numbers and enclosure dimensions reflect contactors with AC coils. For DC coils, select Coil Code from the DC Coil Code table on page C104 and follow the instructions for modifying catalog numbers.

Ordering Instructions

Specify Catalog Number	
Replace (*) with Coil Code Factory Modifications available	Refer to page C104 Refer to pages C107-C111

- ① Dimensional information starts on page C122.
- ② For Type 3R outdoor applications, replace "D" in catalog number with an "R". Dimensions may change. For example catalog number CA7-23-*-D0 becomes CA7-23-*-R0. Price remains the same.
- ③ Contactors are equipped with number and type of auxiliaries indicated. See page C108 to order additional or different auxiliary contacts.
- ④ CA9-116...CA9-370 contactors are available with "EI" option for PLC interface. Change catalog number to include "-EI". Example: CA9-116-*-G0 becomes CA9-116-EI-*-G0. See page C104 for price adder.

Enclosed Contactors

Three Phase, Non-Reversing CA7 & CA9

Continuous Amp Rating - UL/CSA -	Maximum Horsepower Three Phase				Auxiliary Contacts per Contactor ②		Type 4 Watertight	D I M	Type 4X Watertight Corrosion Resistant Non-metallic	D I M
	Enclosed	200V	230V	460V	575V	NO				
25	2	2	5	7.5	1	0	CA7-9-*-W0	N	CA7-9-*-C0	S1
25	3	3	7.5	10	1	0	CA7-12-*-W0	N	CA7-12-*-C0	S1
30	5	5	10	15	1	0	CA7-16-*-W0	N	CA7-16-*-C0	S1
30	5	7.5	15	15	1	0	CA7-23-*-W0	N	CA7-23-*-C0	S1
55	7.5	10	20	25	1	0	CA7-30-*-W0	N	CA7-30-*-C0	S1
60	10	10	25	30	1	0	CA7-37-*-W0	N	CA7-37-*-C0	S1
75	10	15	30	30	1	0	CA7-43-*-W0	N	CA7-43-*-C0	S1
75	15	20	40	40	1	0	CA7-55-*-W0	N	CA7-55-*-C0	S1
90	15	20	40	50	1	0	CA7-60-*-W0	O	CA7-60-*-C0	U1
90	20	25	50	60	1	0	CA7-72-*-W0	O	CA7-72-*-C0	U1
100	25	30	60	60	1	0	CA7-85-*-W0	O	CA7-85-*-C0	U1
120	30	30	75	75	1	0	CA7-97-*-W0	O	CA7-97-*-C0	U1
116	30	40	75	100	1	1	CA9-116-*-W0 ④	Q	CA9-116-*-C0 ④	W2
146	40	50	100	125	1	1	CA9-146-*-W0 ④	Q	CA9-146-*-C0 ④	W2
190	50	60	125	150	1	1	CA9-190-*-W0 ④	R	CA9-190-*-C0 ④	X1
205	60	75	150	200	1	1	CA9-205-*-W0 ④	T	CA9-205-*-C0 ④	X1
265	75	100	200	250	1	1	CA9-265-*-W0 ④	T	CA9-265-*-C0 ④	X1
305	100	125	250	300	1	1	CA9-305-*-W0 ④	H	CA9-305-*-C0 ④	Y1
370	125	150	300	350	1	1	CA9-370-*-W0 ④	H	CA9-370-*-C0 ④	Y1
400	125	150	350	400	1	1	CA9-400-EI-*-W0	R/F	CA9-400-EI-*-C0	R/F
460	150	200	400	500	1	1	CA9-460-EI-*-W0	R/F	CA9-460-EI-*-C0	R/F
480	200	250	500	600	1	1	CA9-580-EI-*-W0	R/F	CA9-580-EI-*-C0	R/F
750	250	300	600	700	1	1	CA9-750-EI-*-W0	R/F	CA9-750-EI-*-C0	R/F
860	~	400	800	1000	1	1	CA9-860-EI-*-W0	R/F	CA9-860-EI-*-C0	R/F
1060	~	450	900	1150	1	1	CA9-1060-EI-*-W0	R/F	CA9-1060-EI-*-C0	R/F

NOTE: Catalog numbers and enclosure dimensions reflect contactors with AC coils. For DC coils, select Coil Code from the DC Coil Code table on page C104 and follow the instructions for modifying catalog numbers.

Ordering Instructions

Specify Catalog Number	
Replace (*) with Coil Code Factory Modifications available	Refer to page C104 Refer to pages C107-C111

- ① Dimensional information starts on page C122.
- ② Contactors are equipped with number and type of auxiliaries indicated. See page C108 to order additional or different auxiliary contacts.
- ③ CA9-116...CA9-370 contactors are available with "EI" option for PLC interface. Change catalog number to include "-EI". Example: CA9-116-*-W0 becomes CA9-116-EI-*-W0. See page C104 for price adder.

Three Phase, Reversing CAU7 & CAU9

Continuous Amp Rating - UL/CSA - Enclosed	Maximum Horsepower Three Phase				Auxiliary Contacts per Contactor ③		Type 1 General Purpose Catalog Number	DIM	Type 12 [Type 3R ②] Industrial Dusttight Catalog Number	DIM
	200V	230V	460V	575V	NO	NC ④				
25	2	2	5	7.5	1	1	CAU7-9-*G0	A	CAU7-9-*D0	M
25	3	3	7.5	10	1	1	CAU7-12-*G0	A	CAU7-12-*D0	M
30	5	5	10	15	1	1	CAU7-16-*G0	A	CAU7-16-*D0	M
30	5	7.5	15	15	1	1	CAU7-23-*G0	A	CAU7-23-*D0	M
55	7.5	10	20	25	1	1	CAU7-30-*G0	A	CAU7-30-*D0	M
60	10	10	25	30	1	1	CAU7-37-*G0	A	CAU7-37-*D0	M
75	10	15	30	30	1	1	CAU7-43-*G0	B	CAU7-43-*D0	M
75	15	20	40	40	1	1	CAU7-55-*G0	B	CAU7-55-*D0	M
90	15	20	40	50	1	1	CAU7-60-*G0	C	CAU7-60-*D0	O
90	20	25	50	60	1	1	CAU7-72-*G0	C	CAU7-72-*D0	O
100	25	30	60	60	1	1	CAU7-85-*G0	C	CAU7-85-*D0	O
120	30	30	75	75	1	1	CAU7-97-*G0	C	CAU7-97-*D0	O
116	30	40	75	100	1	1	CAU9-116-*G0 ⑤	E	CAU9-116-*D0 ⑤	Q
146	40	50	100	125	1	1	CAU9-146-*G0 ⑤	E	CAU9-146-*D0 ⑤	Q
190	50	60	125	150	1	1	CAU9-190-*G0 ⑤	E	CAU9-190-*D0 ⑤	R
205	60	75	150	200	1	1	CAU9-205-*G0 ⑤	F	CAU9-205-*D0 ⑤	T
265	75	100	200	250	1	1	CAU9-265-*G0 ⑤	F	CAU9-265-*D0 ⑤	T
305	100	125	250	300	1	1	CAU9-305-*G0 ⑤	H	CAU9-305-*D0 ⑤	H
370	125	150	300	350	1	1	CAU9-370-*G0 ⑤	H	CAU9-370-*D0 ⑤	H
400	125	150	350	400	1	1	CAU9-400-EI-*G0	R/F	CAU9-400-EI-*D0	R/F
460	150	200	400	500	1	1	CAU9-460-EI-*G0	R/F	CAU9-460-EI-*D0	R/F
480	200	250	500	600	1	1	CAU9-580-EI-*G0	R/F	CAU9-580-EI-*D0	R/F
750	250	300	600	700	1	1	CAU9-750-EI-*G0	R/F	CAU9-750-EI-*D0	R/F
860	~	400	800	1000	1	1	CAU9-860-EI-*G0	R/F	CAU9-860-EI-*D0	R/F
1060	~	450	900	1150	1	1	CAU9-1060-EI-*G0	R/F	CAU9-1060-EI-*D0	R/F

NOTE: Catalog numbers and enclosure dimensions reflect contactors with AC coils. For DC coils, select Coil Code from the DC Coil Code table on page C104 and follow the instructions for modifying catalog numbers.

Ordering Instructions

Specify Catalog Number	
Replace (*) with Coil Code Factory Modifications available	Refer to page C104 Refer to pages C107-C111

- ① Dimensional information starts on page C122.
- ② For Type 3R outdoor applications, replace "D" in catalog number with an "R". Dimensions may change. For example catalog number CAU7-23-*D0 becomes CAU7-23-*R0. Price remains the same.
- ③ Contactors are equipped with number and type of auxiliaries indicated. See page C108 to order additional or different auxiliary contacts.
- ④ One N.C. auxiliary contact is used for electrical interlocking. On CAU7 reversing contactors, the N.C. contact comes from the Mechanical/Electrical Interlock unit (Cat # CM7-02).
- ⑤ CAU9-116...CAU9-370 contactors are available with "EI" option for PLC interface. Change catalog number to include "-EI". Example: CAU9-116-*G0 becomes CAU9-116-EI-*G0. See page C104 for price adder.

Three Phase, Reversing CAU7 & CAU9

Continuous Amp Rating - UL/CSA -	Maximum Horsepower Three Phase				Auxiliary Contacts per Contactor ②		Type 4 Watertight Catalog Number	D I M ①	Type 4X Watertight Corrosion Resistant Non-metallic Catalog Number	D I M ①
	Enclosed	200V	230V	460V	575V	NO				
25	2	2	5	7.5	1	1	CAU7-9-*W0	N	CAU7-9-*C0	U1
25	3	3	7.5	10	1	1	CAU7-12-*W0	N	CAU7-12-*C0	U1
30	5	5	10	15	1	1	CAU7-16-*W0	N	CAU7-16-*C0	U1
30	5	7.5	15	15	1	1	CAU7-23-*W0	N	CAU7-23-*C0	U1
55	7.5	10	20	25	1	1	CAU7-30-*W0	N	CAU7-30-*C0	U1
60	10	10	25	30	1	1	CAU7-37-*W0	N	CAU7-37-*C0	U1
75	10	15	30	30	1	1	CAU7-43-*W0	N	CAU7-43-*C0	U1
75	15	20	40	40	1	1	CAU7-55-*W0	N	CAU7-55-*C0	U1
90	15	20	40	50	1	1	CAU7-60-*W0	O	CAU7-60-*C0	V1
90	20	25	50	60	1	1	CAU7-72-*W0	O	CAU7-72-*C0	V1
100	25	30	60	60	1	1	CAU7-85-*W0	O	CAU7-85-*C0	V1
120	30	30	75	75	1	1	CAU7-97-*W0	O	CAU7-97-*C0	V1
116	30	40	75	100	1	1	CAU9-116-*W0 ④	Q	CAU9-116-*C0 ④	W2
146	40	50	100	125	1	1	CAU9-146-*W0 ④	Q	CAU9-146-*C0 ④	W2
190	50	60	125	150	1	1	CAU9-190-*W0 ④	R	CAU9-190-*C0 ④	X1
205	60	75	150	200	1	1	CAU9-205-*W0 ④	T	CAU9-205-*C0 ④	X1
265	75	100	200	250	1	1	CAU9-265-*W0 ④	T	CAU9-265-*C0 ④	X1
305	100	125	250	300	1	1	CAU9-305-*W0 ④	H	CAU9-305-*C0 ④	Y1
370	125	150	300	350	1	1	CAU9-370-*W0 ④	H	CAU9-370-*C0 ④	Y1
400	125	150	350	400	1	1	CAU9-400-EI-*W0	R/F	CAU9-400-EI-*C0	R/F
460	150	200	400	500	1	1	CAU9-460-EI-*W0	R/F	CAU9-460-EI-*C0	R/F
480	200	250	500	600	1	1	CAU9-580-EI-*W0	R/F	CAU9-580-EI-*C0	R/F
750	250	300	600	700	1	1	CAU9-750-EI-*W0	R/F	CAU9-750-EI-*C0	R/F
860	~	400	800	1000	1	1	CAU9-860-EI-*W0	R/F	CAU9-860-EI-*C0	R/F
1060	~	450	900	1150	1	1	CAU9-1060-EI-*W0	R/F	CAU9-1060-EI-*C0	R/F

NOTE: Catalog numbers and enclosure dimensions reflect contactors with AC coils. For DC coils, select Coil Code from the DC Coil Code table on page C104 and follow the instructions for modifying catalog numbers.

Ordering Instructions

Specify Catalog Number	
Replace (*) with Coil Code Factory Modifications available	Refer to page C104 Refer to pages C107-C111

- ① Dimensional information starts on page C122.
- ② Contactors are equipped with number and type of auxiliaries indicated. See page C108 to order additional or different auxiliary contacts.
- ③ One N.C. auxiliary contact is used for electrical interlocking. On CAU7 reversing contactors, the N.C. contact comes from the Mechanical/Electrical Interlock unit (Cat # CM7-02).
- ④ CAU9-116...CAU9-370 contactors are available with "EI" option for PLC interface. Change catalog number to include "-EI". Example: CAU9-116-*W0 becomes CAU9-116-EI-*W0. See page C104 for price adder.

Single Phase, Non-Reversing CB7

Continuous Amp Rating - UL/CSA -	Maximum Horsepower Single Ø		Auxiliary Contacts per Contactor ③		Type 1 General Purpose Catalog No.	D I M ①	Type 12 [Type 3R ②] Industrial Dusttight Catalog No.	D I M ①	Type 4 Watertight Catalog No.	D I M ①	Type 4X Watertight Corrosion Resistant Non-metallic Catalog No.	D I M ①
	115V	230V	NO	NC								
Enclosed					CB7-		CB7-		CB7-		CB7-	
25	1/2	1 1/2	1	0	9-*G0	A	9-*D0	L	9-*W0	N	9-*C0	S1
25	1/2	2	1	0	12-*G0	A	12-*D0	L	12-*W0	N	12-*C0	S1
30	1	3	1	0	16-*G0	A	16-*D0	L	16-*W0	N	16-*C0	S1
30	2	3	1	0	23-*G0	A	23-*D0	L	23-*W0	N	23-*C0	S1
55	2	5	1	0	30-*G0	A	30-*D0	L	30-*W0	N	30-*C0	S1
60	3	5	1	0	37-*G0	A	37-*D0	L	37-*W0	N	37-*C0	S1
75	3	7 1/2	1	0	43-*G0	A	43-*D0	L	43-*W0	N	43-*C0	S1
75	5	10	1	0	55-*G0	A	55-*D0	L	55-*W0	N	55-*C0	S1
90	5	10	1	0	60-*G0	B	60-*D0	M	60-*W0	O	60-*C0	U1
90	5	15	1	0	72-*G0	B	72-*D0	M	72-*W0	O	72-*C0	U1
100	7 1/2	15	1	0	85-*G0	B	85-*D0	M	85-*W0	O	85-*C0	U1

Larger sizes available. Contact your Sprecher + Schuh representative.

NOTE: Catalog numbers and enclosure dimensions reflect contactors with AC coils. For DC coils, select Coil Code from the DC Coil Code table on page C104 and follow the instructions for modifying catalog numbers.

Ordering Instructions

Specify Catalog Number	
Replace (*) with Coil Code Factory Modifications available	Refer to page C104 Refer to pages C107-C111

- ① Dimensional information starts on page C122.
- ② For Type 3R outdoor applications, replace "D" in catalog number with an "R". Dimensions may change. For example catalog number CB7-23-*D0 becomes CB7-23-*R0. Price remains the same.
- ③ Contactors are equipped with number and type of auxiliaries indicated. See page C108 to order additional or different auxiliary contacts.

Single Phase, Reversing CBUR7 (Reconnectable Winding - Three Lead Motor)

Continuous Amp Rating - UL/CSA -	Maximum Horsepower Single Ø		Auxiliary Contacts per Contactor ③		Type 1 General Purpose	D I M	Type 12 [Type 3R ②] Industrial Dusttight	D I M	Type 4 Watertight	D I M	Type 4X Watertight Corrosion Resistant Non-metallic	D I M
	Enclosed	115V	230V	NO								
					CBUR		CBUR		CBUR		CBUR	
25	1/2	1 1/2	1	1	7-9-*-G0	A	7-9-*-D0	M	7-9-*-W0	N	7-9-*-C0	U1
25	1/2	2	1	1	7-12-*-G0	A	7-12-*-D0	M	7-12-*-W0	N	7-12-*-C0	U1
30	1	3	1	1	7-16-*-G0	A	7-16-*-D0	M	7-16-*-W0	N	7-16-*-C0	U1
30	2	3	1	1	7-23-*-G0	A	7-23-*-D0	M	7-23-*-W0	N	7-23-*-C0	U1
55	2	5	1	1	7-30-*-G0	A	7-30-*-D0	M	7-30-*-W0	N	7-30-*-C0	U1

Single Phase, Reversing CBUS7 (Series Winding – Four Lead Repulsion Induction Motor)

Continuous Amp Rating - UL/CSA -	Maximum Horsepower Single Ø		Auxiliary Contacts per Contactor ③		Type 1 General Purpose	D I M	Type 12 [Type 3R ②] Industrial Dusttight	D I M	Type 4 Watertight	D I M	Type 4X Watertight Corrosion Resistant Non-metallic	D I M
	Enclosed	115V	230V	NO								
					CBUS		CBUS		CBUS		CBUS	
25	1/2	1 1/2	1	1	7-9-*-G0	A	7-9-*-D0	M	7-9-*-W0	N	7-9-*-C0	U1
25	1/2	2	1	1	7-12-*-G0	A	7-12-*-D0	M	7-12-*-W0	N	7-12-*-C0	U1
30	1	3	1	1	7-16-*-G0	A	7-16-*-D0	M	7-16-*-W0	N	7-16-*-C0	U1
30	2	3	1	1	7-23-*-G0	A	7-23-*-D0	M	7-23-*-W0	N	7-23-*-C0	U1
55	2	5	1	1	7-30-*-G0	A	7-30-*-D0	M	7-30-*-W0	N	7-30-*-C0	U1

Single Phase, Reversing CBUP7 (Parallel Winding – Four Lead Capacitor or Split Phase Motor)

Continuous Amp Rating - UL/CSA -	Maximum Horsepower Single Ø		Auxiliary Contacts per Contactor ③		Type 1 General Purpose	D I M	Type 12 [Type 3R ②] Industrial Dusttight	D I M	Type 4 Watertight	D I M	Type 4X Watertight Corrosion Resistant Non-metallic	D I M
	Enclosed	115V	230V	NO								
					CBUP		CBUP		CBUP		CBUP	
25	1/2	1 1/2	1	1	7-9-*-G0	A	7-9-*-D0	M	7-9-*-W0	N	7-9-*-C0	U1
25	1/2	2	1	1	7-12-*-G0	A	7-12-*-D0	M	7-12-*-W0	N	7-12-*-C0	U1
30	1	3	1	1	7-16-*-G0	A	7-16-*-D0	M	7-16-*-W0	N	7-16-*-C0	U1
30	2	3	1	1	7-23-*-G0	A	7-23-*-D0	M	7-23-*-W0	N	7-23-*-C0	U1
55	2	5	1	1	7-30-*-G0	A	7-30-*-D0	M	7-30-*-W0	N	7-30-*-C0	U1

NOTE: Catalog numbers and enclosure dimensions reflect contactors with AC coils. For DC coils, select Coil Code from the DC Coil Code table on page C104 and follow the instructions for modifying catalog numbers.

Ordering Instructions

Specify Catalog Number	Refer to page C104 Refer to pages C107-C111
Replace (*) with Coil Code Factory Modifications available	

- ① Dimensional information starts on page C122.
- ② For Type 3R outdoor applications, replace "D" in catalog number with an "R". Dimensions may change. For example number CBUx7-23-*-D0 becomes CBUx7-23-*-R0. Price remains the same.
- ③ Contactors are equipped with number and type of auxiliaries indicated. See page C108 to order additional or different auxiliary contacts.
- ④ One N.C. auxiliary contact is used for electrical interlocking. On CBU reversing contactors, the N.C. contact comes from the Mechanical/Electrical Interlock unit (Cat # CM7-02).

Enclosed Contactors

Three Phase, Non-Reversing CAN7

NEMA Size	Maximum Horsepower Three Phase				Auxiliary Contacts per Contactor ③		Type 1 General Purpose	DIM	Type 12 [Type 3R ②] Industrial Dusttight	DIM
	200V	230V	460V	575V	NO	NC	Catalog Number		①	
00	3	3	7.5	10	1	0	CAN7-12-*G0	A	CAN7-12-*D0	L
0	5	5	10	15	1	0	CAN7-16-*G0	A	CAN7-16-*D0	L
1	10	10	25	30	1	0	CAN7-37-*G0	A	CAN7-37-*D0	L
2	10	15	30	30	1	0	CAN7-43-*G0	A	CAN7-43-*D0	L
3	25	30	60	60	1	0	CAN7-85-*G0	B	CAN7-85-*D0	M

NEMA Size	Maximum Horsepower Three Phase				Auxiliary Contacts per Contactor ③		Type 4 Watertight	DIM	Type 4X Watertight Corrosion Resistant Non-metallic	DIM
	200V	230V	460V	575V	NO	NC	Catalog Number		①	
00	3	3	7.5	10	1	0	CAN7-12-*W0	N	CAN7-12-*C0	S1
0	5	5	10	15	1	0	CAN7-16-*W0	N	CAN7-16-*C0	S1
1	10	10	25	30	1	0	CAN7-37-*W0	N	CAN7-37-*C0	S1
2	10	15	30	30	1	0	CAN7-43-*W0	N	CAN7-43-*C0	S1
3	25	30	60	60	1	0	CAN7-85-*W0	O	CAN7-85-*C0	U1

NOTE: Catalog numbers and enclosure dimensions reflect contactors with AC coils. For DC coils, select Coil Code from the DC Coil Code table on page C104 and follow the instructions for modifying catalog numbers.

Ordering Instructions

Specify Catalog Number	
Replace (*) with Coil Code Factory Modifications available	Refer to page C104 Refer to pages C107-C111

- ① Dimensional information starts on page C122.
- ② For Type 3R outdoor applications, replace "D" in catalog number with an "R". Dimensions may change. For example number CAN7-23-*D0 becomes CAN7-23-*R0. Price remains the same.
- ③ Contactors are equipped with number and type of auxiliaries indicated. See page C108 to order additional or different auxiliary contacts.

Three Phase, Reversing CAUN7

NEMA Size	Maximum Horsepower Three Phase				Auxiliary Contacts per Contactor ③		Type 1 General Purpose Catalog Number	DIM ①	Type 12 [Type 3R ②] Industrial Dusttight Catalog Number	DIM ①
	200V	230V	460V	575V	NO	NC ④				
00	3	3	7.5	10	1	1	CAUN7-12-*-G0	A	CAUN7-12-*-D0	M
0	5	5	10	15	1	1	CAUN7-16-*-G0	A	CAUN7-16-*-D0	M
1	10	10	25	30	1	1	CAUN7-37-*-G0	A	CAUN7-37-*-D0	M
2	10	15	30	30	1	1	CAUN7-43-*-G0	B	CAUN7-43-*-D0	M
3	25	30	60	60	1	1	CAUN7-85-*-G0	C	CAUN7-85-*-D0	O

NEMA Size	Maximum Horsepower Three Phase				Auxiliary Contacts per Contactor ③		Type 4 Watertight Catalog Number	DIM ①	Type 4X Watertight Corrosion Resistant Non-metallic Catalog Number	DIM ①
	200V	230V	460V	575V	NO	NC ④				
00	3	3	7.5	10	1	1	CAUN7-12-*-W0	N	CAUN7-12-*-C0	U1
0	5	5	10	15	1	1	CAUN7-16-*-W0	N	CAUN7-16-*-C0	U1
1	10	10	25	30	1	1	CAUN7-37-*-W0	N	CAUN7-37-*-C0	U1
2	10	15	30	30	1	1	CAUN7-43-*-W0	N	CAUN7-43-*-C0	U1
3	25	30	60	60	1	1	CAUN7-85-*-W0	O	CAUN7-85-*-C0	V1

NOTE: Catalog numbers and enclosure dimensions reflect contactors with AC coils. For DC coils, select Coil Code from the DC Coil Code table on page C104 and follow the instructions for modifying catalog numbers.

Ordering Instructions

Specify Catalog Number	
Replace (*) with Coil Code Factory Modifications available	Refer to page C104 Refer to pages C107-C111

- ① Dimensional information starts on page C122.
- ② For Type 3R outdoor applications, replace "D" in catalog number with an "R". Dimensions may change. For example number CAUN7-23-*-D0 becomes CAUN7-23-*-R0. Price remains the same.
- ③ Contactors are equipped with number and type of auxiliaries indicated. See page C108 to order additional or different auxiliary contacts.
- ④ One N.C. auxiliary contact is used for electrical interlocking. On CAU7 reversing contactors, the N.C. contact comes from the Mechanical/Electrical Interlock unit (Cat # CM7-02).

Electrically Held with AC Coil

Continuous Ampere Rating ③	Number of Poles	Standard Auxiliary Contacts ⑤		Type 1 General Purpose	D I M	Type 12 [Type 3R ⑥] Industrial Dusttight	D I M
		NO	NC	Catalog Number	④	Catalog Number	④
See page A46	4	0	0	CAL7-20-M40-*-G0		CAL7-20-M40-*-D0	L
	4	0	0	CAL7-30-M40-*-G0		CAL7-30-M40-*-D0	L
	4	0	0	CAL7-60-M40-*-G0		CAL7-60-M40-*-D0	M

Description

The CAL7 electrically held contactors and CAVL7 mechanical held contactors are cUL rated and labeled for tungsten and ballast lighting duty applications at 20, 30, and 60 amperes respectively.

Mechanically Held with AC Coil ①

Continuous Ampere Rating ③	Number of Poles	Standard Auxiliary Contacts ⑤		Type 1 General Purpose	D I M	Type 12 [Type 3R ⑥] Industrial Dusttight	D I M
		NO	NC	Catalog Number	④	Catalog Number	④
See page A46	4	0	0	CAVL7-20-M40-*-G0		CAVL7-20-M40-*-D0	R/F
	4	0	0	CAVL7-30-M40-*-G0		CAVL7-30-M40-*-D0	R/F
	4	0	0	CAVL7-60-M40-*-G0		CAVL7-60-M40-*-D0	R/F

Larger sizes available. Contact your Sprecher + Schuh representative.

NOTE: Catalog numbers and enclosure dimensions reflect contactors with AC coils. For DC coils, select Coil Code from the DC Coil Code table on page C104 and follow the instructions for modifying catalog numbers.

Operation of Mechanically Held Contactor with "ON-OFF" Pushbutton

Catalog number "CAVL7" consists of a CAL7 contactor with CV7-11 mechanical latch. Depressing the "ON" button energizes the "L" coil and the contactor closes. The mechanical latch locks the contactor in the closed position. The "L" coil is then de-energized by the coil, clearing contact "UL" (Terminals 65-66) to remove voltage. Depressing the "OFF" button energizes the "UL" coil, and the mechanical latch releases the contactor. The "UL" coil is immediately de-energized by the coil clearing contact "L" (Terminals 13-14) to remove voltage. The contactor is now open.

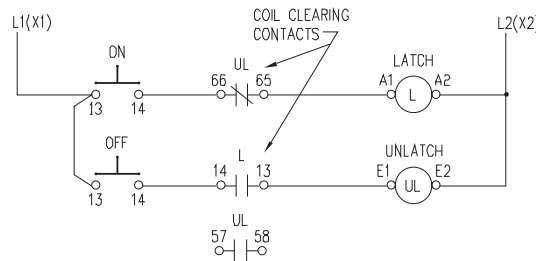

Ordering Instructions

Specify Catalog Number	Refer to page C104 Refer to pages C107-C111
Replace (*) with Coil Code Factory Modifications available	

- ① The N.O. auxiliary is used to mechanically latch the control circuit and is not available for use by customer for other uses.
- ② Engineering practice permits $2.5 \times I_b$ to be applied to a contactor when 3 poles are connected in parallel for single phase discharge lamp (ballast lighting) applications. Example: A CAL7-20-M40-* Lighting Contactor plus a CA7-P-B23 Paralleling Link can be used on a 50A ballast load. Applying parallel conductors to incandescent lamp loads does NOT result in a greater permissible load. Paralleling Links can be found in the Accessories section.
- ③ Dimensional information starts on page C122.
- ④ Contactors are equipped with number and type of auxiliaries indicated. See C108 to order additional or different auxiliary contacts.
- ⑤ For Type 3R outdoor applications, replace "D" in catalog number with an "R". Dimensions may change. For example: CAL7-20-M40-*-D0 becomes CAL7-20-M40-*-R0.

Open and Enclosed Non-Combination Motor Starters

Built to your specifications and ready to install

Sprecher + Schuh magnetic motor starters are intended to eliminate the purchase and assembly of a separate contactor, overload relay and associated wiring. When purchased with an enclosure, the starters are mounted and ready to install on receipt.

Starting with the best

At the heart of all magnetic starters is the Sprecher + Schuh CAT7 and CAT9 line of motor starters. These starters are compact and offer intermediate sizes to better match specific motor requirements. This equates to generous wiring space and less wasted horsepower capacity.

Top line protection...

Magnetic starters are equipped with Sprecher + Schuh's premium CEP7 solid state overload relay standard. Unlike traditional overload relays that indirectly sense motor current through heater elements, CEP7 solid state overload relays measure motor current directly through integrated current transformers and on board electronics. The electronics provide numerous advantages over electromechanical relays. Alternatively, the CT7N Thermal Overload Relay may also be selected.

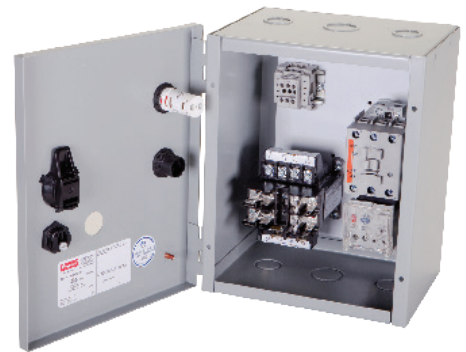

applications, we can house any starter in a custom enclosure of your choosing.

Quality enclosures ensure the highest confidence

Sprecher + Schuh only sources enclosures from name brand manufacturers, ensuring the highest quality. We primarily use enclosures that meet UL Standards, i.e., Type 1, Type 3R, etc., however, we can also source IEC-type enclosures at your request. Enclosures are sized first to accommodate the depth of the contactor and offer sufficient electrical clearances to satisfy UL.

Add a variety of modifications

If you need a larger enclosure than what is specified in our catalog, your sales representative and our Engineering department will work with you to customize any of our enclosed products to suit your exact specifications. Any combination of enclosure types, sizes, pilot devices, meters and other modifications can be combined to provide exactly the panel you need.

The right enclosure... whatever the application

Sprecher + Schuh's broad line of IEC style starters can be purchased pre-installed in a variety of standard enclosures. Cataloged enclosures include:

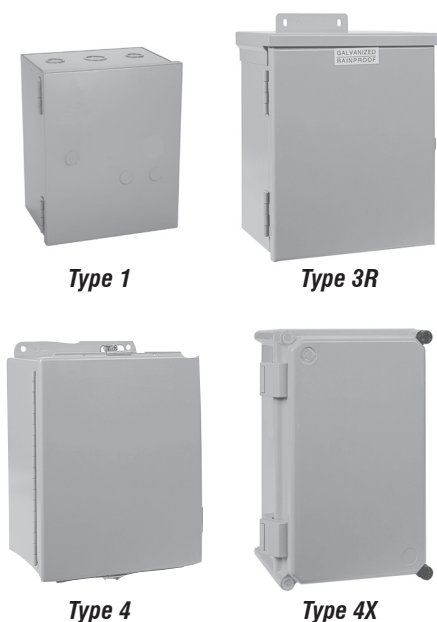

- Type 1** General Purpose
- Type 12** Industrial Dusttight
- Type 3R** Raintight (outdoor)
- Type 4** Watertight
- Type 4X** Watertight, Corrosion Resistant

Even though these are the most popular enclosure types for most industrial

Three Phase, Non-Reversing CAT7 & CAT9

Maximum Horsepower Three Phase				Auxiliary Contacts per Contactor ③		Open Type	Type 1 General Purpose	D I M	Type 12 [Type 3R ④] Industrial Dusttight	D I M
200V	230V	460V	575V	NO	NC	Catalog No.	Catalog No.	①	Catalog No.	①
2	2	5	7 1/2	1	0	CAT7-9-*◆	CAT7-9-*◆-G0	A	CAT7-9-*◆-D0	L
3	3	7 1/2	10	1	0	CAT7-12-*◆	CAT7-12-*◆-G0	A	CAT7-12-*◆-D0	L
5	5	10	15	1	0	CAT7-16-*◆	CAT7-16-*◆-G0	A	CAT7-16-*◆-D0	L
5	7 1/2	15	15	1	0	CAT7-23-*◆	CAT7-23-*◆-G0	A	CAT7-23-*◆-D0	L
7 1/2	10	20	25	1	0	CAT7-30-*◆	CAT7-30-*◆-G0	A	CAT7-30-*◆-D0	L
10	10	25	30	1	0	CAT7-37-*◆	CAT7-37-*◆-G0	A	CAT7-37-*◆-D0	L
10	15	30	30	1	0	CAT7-43-*◆	CAT7-43-*◆-G0	A	CAT7-43-*◆-D0	M
15	20	40	40	1	0	CAT7-55-*◆	CAT7-55-*◆-G0	A	CAT7-55-*◆-D0	M
15	20	40	50	1	0	CAT7-60-*◆	CAT7-60-*◆-G0	B	CAT7-60-*◆-D0	O
20	25	50	60	1	0	CAT7-72-*◆	CAT7-72-*◆-G0	B	CAT7-72-*◆-D0	O
25	30	60	60	1	0	CAT7-85-*◆	CAT7-85-*◆-G0	B	CAT7-85-*◆-D0	O
30	30	75	75	1	0	CAT7-97-*◆	CAT7-97-*◆-G0	O	CAT7-97-*◆-D0	O
30	40	75	100	1	1	CAT9-116-*◆◆④	CAT9-116-*◆◆-G0④	E2	CAT9-116-*◆◆-D0④	R2
40	50	100	125	1	1	CAT9-146-*◆◆④	CAT9-146-*◆◆-G0④	G	CAT9-146-*◆◆-D0④	T
50	60	125	150	1	1	CAT9-190-*◆◆④	CAT9-190-*◆◆-G0④	G	CAT9-190-*◆◆-D0④	T
60	75	150	200	1	1	CAT9-205-*◆◆④	CAT9-205-*◆◆-G0④	G	CAT9-205-*◆◆-D0④	T
75	100	200	250	1	1	CAT9-265-*◆◆④	CAT9-265-*◆◆-G0④	I	CAT9-265-*◆◆-D0④	I
100	125	250	300	1	1	CAT9-305-*◆◆④	CAT9-305-*◆◆-G0④	I	CAT9-305-*◆◆-D0④	I
125	150	300	350	1	1	CAT9-370-*◆◆④	CAT9-370-*◆◆-G0④	I	CAT9-370-*◆◆-D0④	I
125	150	350	400	1	1	CAT9-400-EI-*◆	CAT9-400-EI-*◆-G0	R/F	CAT9-400-EI-*◆-D0	R/F
150	200	400	500	1	1	CAT9-460-EI-*◆	CAT9-460-EI-*◆-G0	R/F	CAT9-460-EI-*◆-D0	R/F
200	250	500	600	1	1	CAT9-580-EI-*◆	CAT9-580-EI-*◆-G0	R/F	CAT9-580-EI-*◆-D0	R/F
250	300	600	700	1	1	CAT9-750-EI-*◆	CAT9-750-EI-*◆-G0	R/F	CAT9-750-EI-*◆-D0	R/F
~	400	800	1000	1	1	CAT9-860-EI-*◆	CAT9-860-EI-*◆-G0	R/F	CAT9-860-EI-*◆-D0	R/F
~	450	900	1150	1	1	CAT9-1060-EI-*◆	CAT9-1060-EI-*◆-G0	R/F	CAT9-1060-EI-*◆-D0	R/F

NOTE: Catalog numbers and enclosure dimensions reflect contactors with AC coils. For DC coils, select Coil Code from the DC Coil Code table on page C104 and follow the instructions for modifying catalog numbers.

Ordering Instructions

Specify Catalog Number	
Replace (*) with Coil Code	See page C104
Replace (◆) with O/L Relay	See pages C105-C106
Factory Modifications available	See pages C107-C111

- ① Dimensional information starts on page C122.
- ② For Type 3R outdoor applications, replace "D" in catalog number with an "R". Dimensions may change. For example number CAT7-23-*◆-D0 becomes CAT7-23-*◆-R0. Price remains the same.
- ③ Contactors are equipped with number and type of auxiliaries indicated. See page C108 to order additional or different auxiliary contacts.
- ④ CAT9-116...CAT9-370 starters are available with "EI" option for PLC interface. Change catalog number to include "-EI". Example: CAT9-116-*◆ becomes CAT9-116-EI-*◆.

Three Phase, Non-Reversing CAT7 & CAT9

Maximum Horsepower Three Phase				Auxiliary Contacts per Contactor ②		Type 4 Watertight	D I M	Type 4X Watertight Corrosion Resistant Non-metallic	D I M
200V	230V	460V	575V	NO	NC	Catalog No.	①	Catalog No.	①
2	2	5	7 1/2	1	0	CAT7-9-*-*♦-W0	N	CAT7-9-*-*♦-C0	S1
3	3	7 1/2	10	1	0	CAT7-12-*-*♦-W0	N	CAT7-12-*-*♦-C0	S1
5	5	10	15	1	0	CAT7-16-*-*♦-W0	N	CAT7-16-*-*♦-C0	S1
5	7 1/2	15	15	1	0	CAT7-23-*-*♦-W0	N	CAT7-23-*-*♦-C0	S1
7 1/2	10	20	25	1	0	CAT7-30-*-*♦-W0	O	CAT7-30-*-*♦-C0	U1
10	10	25	30	1	0	CAT7-37-*-*♦-W0	O	CAT7-37-*-*♦-C0	U1
10	15	30	30	1	0	CAT7-43-*-*♦-W0	O	CAT7-43-*-*♦-C0	U1
15	20	40	40	1	0	CAT7-55-*-*♦-W0	O	CAT7-55-*-*♦-C0	U1
15	20	40	50	1	0	CAT7-60-*-*♦-W0	O	CAT7-60-*-*♦-C0	U1
20	25	50	60	1	0	CAT7-72-*-*♦-W0	O	CAT7-72-*-*♦-C0	U1
25	30	60	60	1	0	CAT7-85-*-*♦-W0	O	CAT7-85-*-*♦-C0	U1
30	30	75	75	1	0	CAT7-97-*-*♦-W0	O	CAT7-97-*-*♦-C0	V1
30	40	75	100	1	1	CAT9-116-*-*♦-W0 ③	R2	CAT9-116-*-*♦-C0 ③	W2
40	50	100	125	1	1	CAT9-146-*-*♦-W0 ③	T	CAT9-146-*-*♦-C0 ③	X1
50	60	125	150	1	1	CAT9-190-*-*♦-W0 ③	T	CAT9-190-*-*♦-C0 ③	X1
60	75	150	200	1	1	CAT9-205-*-*♦-W0 ③	T	CAT9-205-*-*♦-C0 ③	X1
75	100	200	250	1	1	CAT9-265-*-*♦-W0 ③	J	CAT9-265-*-*♦-C0 ③	X1
100	125	250	300	1	1	CAT9-305-*-*♦-W0 ③	J	CAT9-305-*-*♦-C0 ③	Y1
125	150	300	350	1	1	CAT9-370-*-*♦-W0 ③	J	CAT9-370-*-*♦-C0 ③	Y1
125	150	350	400	1	1	CAT9-400-EI-*-*♦-W0	R/F	CAT9-400-EI-*-*♦-C0	R/F
150	200	400	500	1	1	CAT9-460-EI-*-*♦-W0	R/F	CAT9-460-EI-*-*♦-C0	R/F
200	250	500	600	1	1	CAT9-580-EI-*-*♦-W0	R/F	CAT9-580-EI-*-*♦-C0	R/F
250	300	600	700	1	1	CAT9-750-EI-*-*♦-W0	R/F	CAT9-750-EI-*-*♦-C0	R/F
~	400	800	1000	1	1	CAT9-860-EI-*-*♦-W0	R/F	CAT9-860-EI-*-*♦-C0	R/F
~	450	900	1150	1	1	CAT9-1060-EI-*-*♦-W0	R/F	CAT9-1060-EI-*-*♦-C0	R/F

NOTE: Catalog numbers and enclosure dimensions reflect contactors with AC coils. For DC coils, select Coil Code from the DC Coil Code table on page C104 and follow the instructions for modifying catalog numbers.

Ordering Instructions

Specify Catalog Number	See page C104 See pages C105-C106 See pages C107-C111
Replace (*) with Coil Code	
Replace (♦) with O/L Relay Factory Modifications available	

- ① Dimensional information starts on page C122.
- ② Contactors are equipped with number and type of auxiliaries indicated. See page C108 to order additional or different auxiliary contacts.
- ③ CAT9-116...CAT9-370 starters are available with "EI" option for PLC interface. Change catalog number to include "-EI". Example: CAT9-116-*-*♦-W0 becomes CAT9-116-EI-*-*♦-W0. See page C104 for price adder.

Three Phase, Reversing CAUT7 & CAUT9

Maximum Horsepower Three Phase				Auxiliary Contacts per Contactor ③		Open Type	Type 1 General Purpose	D I M	Type 12 [Type 3R ②] Industrial Dusttight	D I M
200V	230V	460V	575V	NO	NC ④					
2	2	5	7 1/2	1	1	CAUT7-9-*◆	CAUT7-9-*◆-G0	A	CAUT7-9-*◆-D0	M
3	3	7 1/2	10	1	1	CAUT7-12-*◆	CAUT7-12-*◆-G0	A	CAUT7-12-*◆-D0	M
5	5	10	15	1	1	CAUT7-16-*◆	CAUT7-16-*◆-G0	A	CAUT7-16-*◆-D0	M
5	7 1/2	15	15	1	1	CAUT7-23-*◆	CAUT7-23-*◆-G0	A	CAUT7-23-*◆-D0	M
7 1/2	10	20	25	1	1	CAUT7-30-*◆	CAUT7-30-*◆-G0	A	CAUT7-30-*◆-D0	M
10	10	25	30	1	1	CAUT7-37-*◆	CAUT7-37-*◆-G0	A	CAUT7-37-*◆-D0	M
10	15	30	30	1	1	CAUT7-43-*◆	CAUT7-43-*◆-G0	B	CAUT7-43-*◆-D0	M
15	20	40	40	1	1	CAUT7-55-*◆	CAUT7-55-*◆-G0	B	CAUT7-55-*◆-D0	M
15	20	40	50	1	1	CAUT7-60-*◆	CAUT7-60-*◆-G0	C	CAUT7-60-*◆-D0	O
20	25	50	60	1	1	CAUT7-72-*◆	CAUT7-72-*◆-G0	C	CAUT7-72-*◆-D0	O
25	30	60	60	1	1	CAUT7-85-*◆	CAUT7-85-*◆-G0	C	CAUT7-85-*◆-D0	O
30	30	75	75	1	1	CAUT7-97-*◆	CAUT7-97-*◆-G0	C	CAUT7-97-*◆-D0	O
30	40	75	100	1	1	CAUT9-116-*◆⑤	CAUT9-116-*◆-G0⑤	E2	CAUT9-116-*◆-D0⑤	R2
40	50	100	125	1	1	CAUT9-146-*◆⑤	CAUT9-146-*◆-G0⑤	G	CAUT9-146-*◆-D0⑤	T
50	60	125	150	1	1	CAUT9-190-*◆⑤	CAUT9-190-*◆-G0⑤	G	CAUT9-190-*◆-D0⑤	T
60	75	150	200	1	1	CAUT9-205-*◆⑤	CAUT9-205-*◆-G0⑤	G	CAUT9-205-*◆-D0⑤	T
75	100	200	250	1	1	CAUT9-265-*◆⑤	CAUT9-265-*◆-G0⑤	I	CAUT9-265-*◆-D0⑤	I
100	125	250	300	1	1	CAUT9-305-*◆⑤	CAUT9-305-*◆-G0⑤	I	CAUT9-305-*◆-D0⑤	I
125	150	300	350	1	1	CAUT9-370-*◆⑤	CAUT9-370-*◆-G0⑤	I	CAUT9-370-*◆-D0⑤	I
125	150	350	400	1	1	CAUT9-400-EI-*◆	CAUT9-400-EI-*◆-G0	R/F	CAUT9-400-EI-*◆-D0	R/F
150	200	400	500	1	1	CAUT9-460-EI-*◆	CAUT9-460-EI-*◆-G0	R/F	CAUT9-460-EI-*◆-D0	R/F
200	250	500	600	1	1	CAUT9-580-EI-*◆	CAUT9-580-EI-*◆-G0	R/F	CAUT9-580-EI-*◆-D0	R/F
250	300	600	700	1	1	CAUT9-750-EI-*◆	CAUT9-750-EI-*◆-G0	R/F	CAUT9-750-EI-*◆-D0	R/F
~	400	800	1000	1	1	CAUT9-860-EI-*◆	CAUT9-860-EI-*◆-G0	R/F	CAUT9-860-EI-*◆-D0	R/F
~	450	900	1150	1	1	CAUT9-1060-EI-*◆	CAUT9-1060-EI-*◆-G0	R/F	CAUT9-1060-EI-*◆-D0	R/F

NOTE: Catalog numbers and enclosure dimensions reflect contactors with AC coils. For DC coils, select Coil Code from the DC Coil Code table on page C104 and follow the instructions for modifying catalog numbers.

Ordering Instructions

Specify Catalog Number	
Replace (*) with Coil Code	See page C104
Replace (◆) with O/L Relay	See pages C105-C106
Factory Modifications available	See pages C107-C111

- ① Dimensional information starts on page C122.
- ② For Type 3R outdoor applications, replace "D" in catalog number with an "R". Dimensions may change. For example number CAUT7-23-*◆-D0 becomes CAUT7-23-*◆-R0.
- ③ Contactors are equipped with number and type of auxiliaries indicated. See page C108 to order additional or different auxiliary contacts.
- ④ One N.C. auxiliary contact is used for electrical interlocking. On CAUT7 reversing starters, the N.C. contact comes from the Mechanical/Electrical Interlock unit (Cat # CM7-02).
- ⑤ CAUT9-116...CAUT9-370 starters are available with "EI" option for PLC interface. Change catalog number to include "-EI". Example: CAUT9-116-*◆ becomes CAUT9-116-EI-*◆.

Three Phase, Reversing CAUT7 & CAUT9

Maximum Horsepower Three Phase				Auxiliary Contacts per Contactor ②		Type 4 Watertight	D I M	Type 4X Watertight Corrosion Resistant Non-metallic	D I M
200V	230V	460V	575V	NO	NC ③	Catalog No.		① Catalog No.	
2	2	5	7 1/2	1	1	CAUT7-9-*-*♦-W0	N	CAUT7-9-*-*♦-C0	U1
3	3	7 1/2	10	1	1	CAUT7-12-*-*♦-W0	N	CAUT7-12-*-*♦-C0	U1
5	5	10	15	1	1	CAUT7-16-*-*♦-W0	N	CAUT7-16-*-*♦-C0	U1
5	7 1/2	15	15	1	1	CAUT7-23-*-*♦-W0	N	CAUT7-23-*-*♦-C0	U1
7 1/2	10	20	25	1	1	CAUT7-30-*-*♦-W0	O	CAUT7-30-*-*♦-C0	U1
10	10	25	30	1	1	CAUT7-37-*-*♦-W0	O	CAUT7-37-*-*♦-C0	U1
10	15	30	30	1	1	CAUT7-43-*-*♦-W0	O	CAUT7-43-*-*♦-C0	U1
15	20	40	40	1	1	CAUT7-55-*-*♦-W0	O	CAUT7-55-*-*♦-C0	U1
15	20	40	50	1	1	CAUT7-60-*-*♦-W0	O	CAUT7-60-*-*♦-C0	V1
20	25	50	60	1	1	CAUT7-72-*-*♦-W0	O	CAUT7-72-*-*♦-C0	V1
25	30	60	60	1	1	CAUT7-85-*-*♦-W0	O	CAUT7-85-*-*♦-C0	V1
30	30	75	75	1	1	CAUT7-97-*-*♦-W0	O	CAUT7-97-*-*♦-C0	V1
30	40	75	100	1	1	CAUT9-116-*-*♦-W0 ④	R2	CAUT9-116-*-*♦-C0 ④	W2
40	50	100	125	1	1	CAUT9-146-*-*♦-W0 ④	T	CAUT9-146-*-*♦-C0 ④	X1
50	60	125	150	1	1	CAUT9-190-*-*♦-W0 ④	T	CAUT9-190-*-*♦-C0 ④	X1
60	75	150	200	1	1	CAUT9-205-*-*♦-W0 ④	T	CAUT9-205-*-*♦-C0 ④	X1
75	100	200	250	1	1	CAUT9-265-*-*♦-W0 ④	J	CAUT9-265-*-*♦-C0 ④	Y1
100	125	250	300	1	1	CAUT9-305-*-*♦-W0 ④	J	CAUT9-305-*-*♦-C0 ④	Y1
125	150	300	350	1	1	CAUT9-370-*-*♦-W0 ④	J	CAUT9-370-*-*♦-C0 ④	Y1
125	150	350	400	1	1	CAUT9-400-EI-*-*♦-W0	R/F	CAUT9-400-EI-*-*♦-C0	R/F
150	200	400	500	1	1	CAUT9-460-EI-*-*♦-W0	R/F	CAUT9-460-EI-*-*♦-C0	R/F
200	250	500	600	1	1	CAUT9-580-EI-*-*♦-W0	R/F	CAUT9-580-EI-*-*♦-C0	R/F
250	300	600	700	1	1	CAUT9-750-EI-*-*♦-W0	R/F	CAUT9-750-EI-*-*♦-C0	R/F
~	400	800	1000	1	1	CAUT9-860-EI-*-*♦-W0	R/F	CAUT9-860-EI-*-*♦-C0	R/F
~	450	900	1150	1	1	CAUT9-1060-EI-*-*♦-W0	R/F	CAUT9-1060-EI-*-*♦-C0	R/F

NOTE: Catalog numbers and enclosure dimensions reflect contactors with AC coils. For DC coils, select Coil Code from the DC Coil Code table on page C104 and follow the instructions for modifying catalog numbers.

Ordering Instructions

Specify Catalog Number	
Replace (*) with Coil Code	See page C104
Replace ♦ with O/L Relay	See pages C105-C106
Factory Modifications available	See pages C107-C111

- ① Dimensional information starts on page C122.
- ② Contactors are equipped with number and type of auxiliaries indicated. See page C108 to order additional or different auxiliary contacts.
- ③ One N.C. auxiliary contact is used for electrical interlocking. On CAUT7 reversing starters, the N.C. contact comes from the Mechanical/Electrical Interlock unit (Cat # CM7-02).
- ④ CAUT9-116...CAUT9-370 starters are available with "EI" option for PLC interface. Change catalog number to include "-EI". Example: CAUT9-116-*-*♦-W0 becomes CAUT9-116-EI-*-*♦-W0.

C
Non-Combination Starters

Single Phase, Non-Reversing CBT7

Maximum Horsepower Single Ø		Auxiliary Contacts per Contactor ③		Open Type	Type 1 General Purpose	D I M	Type 12 [Type 3R ②] Industrial Dusttight	D I M	Type 4 Watertight	D I M	Type 4X Watertight Corrosion Resistant	D I M
115V	230V	NO	NC	Catalog No.	Catalog No.	①	Catalog No.	①	Catalog No.	①	Catalog No.	①
				CBT7-	CBT7-		CBT7-		CBT7-		CBT7-	
1/2	1 1/2	1	0	9-*-◆	9-*-◆-G0	A	9-*-◆-D0	L	9-*-◆-W0	N	9-*-◆-C0	S1
1/2	2	1	0	12-*-◆	12-*-◆-G0	A	12-*-◆-D0	L	12-*-◆-W0	N	12-*-◆-C0	S1
1	3	1	0	16-*-◆	16-*-◆-G0	A	16-*-◆-D0	L	16-*-◆-W0	N	16-*-◆-C0	S1
2	3	1	0	23-*-◆	23-*-◆-G0	A	23-*-◆-D0	L	23-*-◆-W0	N	23-*-◆-C0	S1
2	5	1	0	30-*-◆	30-*-◆-G0	A	30-*-◆-D0	L	30-*-◆-W0	O	30-*-◆-C0	U1
3	5	1	0	37-*-◆	37-*-◆-G0	A	37-*-◆-D0	L	37-*-◆-W0	O	37-*-◆-C0	U1
3	7 1/2	1	0	43-*-◆	43-*-◆-G0	A	43-*-◆-D0	M	43-*-◆-W0	O	43-*-◆-C0	U1
5	10	1	0	60-*-◆	60-*-◆-G0	B	60-*-◆-D0	O	60-*-◆-W0	O	60-*-◆-C0	U1
5	15	1	0	72-*-◆	72-*-◆-G0	B	72-*-◆-D0	O	72-*-◆-W0	O	72-*-◆-C0	U1
7 1/2	15	1	0	85-*-◆	85-*-◆-G0	B	85-*-◆-D0	O	85-*-◆-W0	O	85-*-◆-C0	U1

NOTE: Catalog numbers and enclosure dimensions reflect contactors with AC coils. For DC coils, select Coil Code from the DC Coil Code table on page C104 and follow the instructions for modifying catalog numbers.

Ordering Instructions

Specify Catalog Number	
Replace (*) with Coil Code	See page C104
Replace (◆) with O/L Relay	See pages C105-C106
Factory Modifications available	See pages C107-C111

- ① Dimensional information starts on page C122.
- ② For Type 3R outdoor applications, replace "D" in catalog number with an "R". Dimensions may change. For example number CBT7-23-*-◆-D0 becomes CBT7-23-*-◆-R0.
- ③ Contactors are equipped with number and type of auxiliaries indicated. See page C108 to order additional or different auxiliary contacts.

Single Phase, Reversing CBUTR7 (Reconnectable Winding – Three Lead Motor)

Maximum Horsepower Single Ø		Auxiliary Contacts per Contactor ③		Open Type	Type 1 General Purpose	D I M	Type 12 [Type 3R ②] Industrial Dusttight	D I M	Type 4 Watertight	D I M	Type 4X Watertight Corrosion Resistant Non-metallic	D I M
115V	230V	NO	NC ④	Catalog No.	Catalog No.	①	Catalog No.	①	Catalog No.	①	Catalog No.	①
				CBUTR7-	CBUTR7-		CBUTR7-		CBUTR7-		CBUTR7-	
1/2	1 1/2	1	1	9-*◆	9-*◆-G0	A	9-*◆-D0	M	9-*◆-W0	N	9-*◆-C0	U1
1/2	2	1	1	12-*◆	12-*◆-G0	A	12-*◆-D0	M	12-*◆-W0	N	12-*◆-C0	U1
1	3	1	1	16-*◆	16-*◆-G0	A	16-*◆-D0	M	16-*◆-W0	N	16-*◆-C0	U1
2	3	1	1	23-*◆	23-*◆-G0	A	23-*◆-D0	M	23-*◆-W0	N	23-*◆-C0	U1
2	5	1	1	30-*◆	30-*◆-G0	A	30-*◆-D0	M	30-*◆-W0	O	30-*◆-C0	U1

Single Phase, Reversing CBUTS7 (Series Winding – Four Lead Repulsion Induction Motor)

Maximum Horsepower Single Ø		Auxiliary Contacts per Contactor ③		Open Type	Type 1 General Purpose	D I M	Type 12 [Type 3R ②] Industrial Dusttight	D I M	Type 4 Watertight	D I M	Type 4X Watertight Corrosion Resistant Non-metallic	D I M
115V	230V	NO	NC ④	Catalog No.	Catalog No.	①	Catalog No.	①	Catalog No.	①	Catalog No.	①
				CBUTS7-	CBUTS7-		CBUTS7-		CBUTS7-		CBUTS7-	
1/2	1 1/2	1	1	9-*◆	9-*◆-G0	A	9-*◆-D0	M	9-*◆-W0	N	9-*◆-C0	U1
1/2	2	1	1	12-*◆	12-*◆-G0	A	12-*◆-D0	M	12-*◆-W0	N	12-*◆-C0	U1
1	3	1	1	16-*◆	16-*◆-G0	A	16-*◆-D0	M	16-*◆-W0	N	16-*◆-C0	U1
2	3	1	1	23-*◆	23-*◆-G0	A	23-*◆-D0	M	23-*◆-W0	N	23-*◆-C0	U1
2	5	1	1	30-*◆	30-*◆-G0	A	30-*◆-D0	M	30-*◆-W0	O	30-*◆-C0	U1

Single Phase, Reversing CBUTP7 (Parallel Winding – Four Lead Capacitor or Split Phase Motor)

Maximum Horsepower Single Ø		Auxiliary Contacts per Contactor ③		Open Type	Type 1 General Purpose	D I M	Type 12 [Type 3R ②] Industrial Dusttight	D I M	Type 4 Watertight	D I M	Type 4X Watertight Corrosion Resistant Non-metallic	D I M
115V	230V	NO	NC ④	Catalog No.	Catalog No.	①	Catalog No.	①	Catalog No.	①	Catalog No.	①
				CBUTP7-	CBUTP7-		CBUTP7-		CBUTP7-		CBUTP7-	
1/2	1 1/2	1	1	9-*◆	9-*◆-G0	A	9-*◆-D0	M	9-*◆-W0	N	9-*◆-C0	U1
1/2	2	1	1	12-*◆	12-*◆-G0	A	12-*◆-D0	M	12-*◆-W0	N	12-*◆-C0	U1
1	3	1	1	16-*◆	16-*◆-G0	A	16-*◆-D0	M	16-*◆-W0	N	16-*◆-C0	U1
2	3	1	1	23-*◆	23-*◆-G0	A	23-*◆-D0	M	23-*◆-W0	N	23-*◆-C0	U1
2	5	1	1	30-*◆	30-*◆-G0	A	30-*◆-D0	M	30-*◆-W0	O	30-*◆-C0	U1

NOTE: Catalog numbers and enclosure dimensions reflect contactors with AC coils. For DC coils, select Coil Code from the DC Coil Code table on page C104 and follow the instructions for modifying catalog numbers.

Ordering Instructions

Specify Catalog Number	
Replace (*) with Coil Code	See page C104
Replace ◆ with O/L Relay	See pages C105-C106
Factory Modifications available	See pages C107-C111

- ① Dimensional information starts on page C122.
- ② For Type 3R outdoor applications, replace "D" in catalog number with an "R". Dimensions may change. For example number CBUTx7-23-*◆-D0 becomes CBUTx7-23-*◆-R0.
- ③ Contactors are equipped with number and type of auxiliaries indicated. See page C108 to order additional or different auxiliary contacts.
- ④ One N.C. auxiliary contact is used for electrical interlocking. On CAUT7 reversing starters, the N.C. contact comes from the Mechanical/Electrical Interlock unit (Cat # CM7-02).

NEMA Sized Open and Enclosed Non-Combination Motor Starters

Built to your specifications and ready to install

Sprecher + Schuh magnetic motor starters are intended to eliminate the purchase and assembly of a separate contactor, overload relay and associated wiring. When purchased with an enclosure, the starters are mounted and ready to install on receipt.

Starting with the best

At the heart of all Sprecher + Schuh NEMA sized magnetic motor starters is the CATN7 line of motor starters. Each starter proudly displays the NEMA size (00, 0, 1, 2, or 3) and HP at applied voltage. This line of starters is designed to meet rigid consultant specifications for NEMA starters.

Top line protection...



NEMA labeled magnetic starters are equipped with Sprecher + Schuh's premium CEP7 solid state overload relay standard. Unlike traditional overload relays that indirectly sense motor current through heater elements, CEP7 solid state overload relays measure the current directly through the energizing contact transformer on the motor. The electronic platform offers numerous advantages over electromechanical relays. Alternatively, the CT7N Thermal Overload Relay may also be selected.

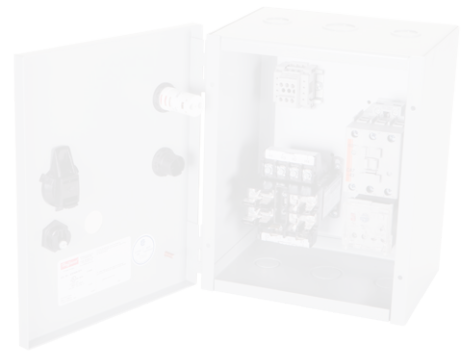

Even though these are the most popular enclosure types for most industrial applications, we can house any starter in a custom enclosure of your choosing.

Quality enclosures ensure the highest confidence

Sprecher + Schuh only sources enclosures from name brand manufacturers, ensuring the highest quality. We primarily use enclosures that meet NEMA standards, i.e., Type 1, Type 12, etc., however, we can also source other enclosures at your request. Enclosures are sized first to accommodate the depth of the contactor and offer sufficient electrical clearances to satisfy UL.

Add a variety of modifications

If you need a larger enclosure than what is specified in our catalog, your sales representative and our Engineering department will work with you to customize any of our enclosed products to suit your exact specifications. Any combination of enclosure types, sizes, pilot devices, meters and other modifications can be combined to provide exactly the panel you need.

See new NEMA Starters Section starting at page 101.1



See new NEMA labeled contactor (AC)

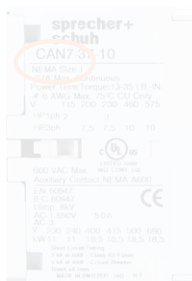
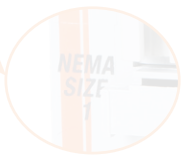

The right enclosure... whatever the application

Sprecher + Schuh's line of NEMA style starters can be purchased pre-installed in a variety of standard enclosures. Cataloged enclosures include:

- Type 1 General Purpose
- Type 12 Industrial Dusttight
- Type 3R Raintight (outdoor)
- Type 4 Watertight
- Type 4X Watertight, Corrosion Resistant



Type 1

Type 3R

Type 4

Type 4X

Three Phase, Non-Reversing CATN7

NEMA Size	Maximum Horsepower Three Phase				Auxiliary Contacts per Contactor ③		Open Type	Type 1 General Purpose	DIM	Type 12 [Type 3R ②] Industrial Dusttight	DIM
	200V	230V	460V	575V	NO	NC					
00	1-1/2	1-1/2	2	2	1	0	CATN7-12-*-◆	CATN7-12-*-◆-G0	A	CATN7-12-*-◆-D0	L
0	3	3	5	5	1	0	CATN7-16-*-◆	CATN7-16-*-◆-G0	A	CATN7-16-*-◆-D0	L
1	7-1/2	7-1/2	10	10	1	0	CATN7-37-*-◆	CATN7-37-*-◆-G0	A	CATN7-37-*-◆-D0	L
2	10	15	25	25	1	0	CATN7-43-*-◆	CATN7-43-*-◆-G0	A	CATN7-43-*-◆-D0	L
3	25	30	50	50	1	0	CATN7-85-*-◆	CATN7-85-*-◆-G0	B	CATN7-85-*-◆-D0	M

Three Phase, Non-Reversing CATN7

NEMA Size	Maximum Horsepower Three Phase				Auxiliary Contacts per Contactor ③		Type 4 Watertight	DIM	Type 4X Watertight Corrosion Resistant Non-metallic	DIM
	200V	230V	460V	575V	NO	NC				
00	1-1/2	1-1/2	2	2	1	0	CATN7-12-*-◆-W0	N	CATN7-12-*-◆-C0	U1
0	3	3	5	5	1	0	CATN7-16-*-◆-W0	N	CATN7-16-*-◆-C0	U1
1	7-1/2	7-1/2	10	10	1	0	CATN7-37-*-◆-W0	N	CATN7-37-*-◆-C0	U1
2	10	15	25	25	1	0	CATN7-43-*-◆-W0	N	CATN7-43-*-◆-C0	U1
3	25	30	50	50	1	0	CATN7-85-*-◆-W0	N	CATN7-85-*-◆-C0	U1

NOTE: Catalog numbers and enclosure dimensions refer to catalog number. For DC coils, select Coil Code from the DC Coil Code table on page C104 and follow the instructions for modifying catalog numbers.

This page has moved. See new NEMA Starters Section starting at page 101.1

NEMA Non-Combination Starters

Ordering Instructions

Specify Catalog Number	
Replace (□) with Coil Code	See page C104
Replace (◆) with O/L Relay	See pages C105-C106
Factory Modifications available	See pages C107-C111

- ① Dimensional information starts on page C122.
- ② For Type 3R outdoor applications, replace "D" in catalog number with an "R". Dimensions may change. For example number CATN7-37-*-◆-D0 becomes CATN7-37-*-◆-R0.
- ③ Contactors are equipped with number and type of auxiliaries indicated. See page C108 to order additional or different auxiliary contacts.

Three Phase, Non-Reversing CATN7 @208V AC Non-Combination Starter

NEMA Size	Max HP 3-Phase ①	Auxiliary Contacts per Contactor ②		Type 1 Metallic General Purpose	DIM	Type 3R Metallic Outdoor Raintight	DIM
		208V	NO	NC		Catalog Number	
00	0.25	2	1	CATN7-12-XA-D1B8-G17-L11	A	CATN7-12-XA-D1B8-R17-L11	L
	0.5	2	1	CATN7-12-XA-D1C8-G17-L11	A	CATN7-12-XA-D1C8-R17-L11	L
	0.75	2	1	CATN7-12-XA-D1C8-G17-L11	A	CATN7-12-XA-D1C8-R17-L11	L
	1	2	1	CATN7-12-XA-D1C8-G17-L11	A	CATN7-12-XA-D1C8-R17-L11	L
	1.5	2	1	CATN7-12-XA-D1DB-G17-L11	A	CATN7-12-XA-D1DB-R17-L11	L
0	2	2	1	CATN7-16-XA-D1DB-G17-L11	A	CATN7-16-XA-D1DB-R17-L11	L
	3	2	1	CATN7-16-XA-D1DB-G17-L11	A	CATN7-16-XA-D1DB-R17-L11	L
1	5	2	1	CATN7-37-XA-D1ED-G17-L11	A	CATN7-37-XA-D1ED-R17-L11	L
	7.5	2	1	CATN7-37-XA-D1ED-G17-L11	A	CATN7-37-XA-D1ED-R17-L11	L
2	10	2	1	CATN7-43-XA-D1FD-G17-L11	A	CATN7-43-XA-D1FD-R17-L11	L
	15	2	1	CATN7-85-XA-EGE-G17-L11	B	CATN7-85-XA-EGE-R17-L11	M
3	20	2	1	CATN7-85-XA-EGE-G17-L11	B	CATN7-85-XA-EGE-R17-L11	M
	25	2	1	CATN7-85-XA-EGE-G17-L11	B	CATN7-85-XA-EGE-R17-L11	M

Full Voltage Non-Reversing (FVNR) Features include:

- NEMA-sized CAN7 contactor
- Three-Phase CEP7 Electronic Overload Relay
- Control Circuit Transformer
- Hand-Off-Auto (H-O-A) selector switch
- Red Run pilot light
- 2-NO and 1-NC auxiliaries for customer use
- Class CC Fuse holder as fused primary of CCT
- Reset pushbutton

See new NEMA Starters Section starting at page 101.1

This page has moved.

Three Phase, Non-Reversing CATN7 @230V AC Non-Combination Starter

NEMA Size	Max HP 3-Phase ①	Auxiliary Contacts per Contactor ②		Type 1 Metallic General Purpose	DIM	Type 3R Metallic Outdoor Raintight	DIM
		230V	NO	NC		③ Catalog Number	
00	0.25	2	1	CATN7-12-XB-D1B8-G17-L11	A	CATN7-12-XB-D1B8-R17-L11	L
	0.5	2	1	CATN7-12-XB-D1C8-G17-L11	A	CATN7-12-XB-D1C8-R17-L11	L
	0.75	2	1	CATN7-12-XB-D1C8-G17-L11	A	CATN7-12-XB-D1C8-R17-L11	L
	1	2	1	CATN7-12-XB-D1C8-G17-L11	A	CATN7-12-XB-D1C8-R17-L11	L
	1.5	2	1	CATN7-12-XB-D1C8-G17-L11	A	CATN7-12-XB-D1C8-R17-L11	L
0	2	2	1	CATN7-16-XB-D1DB-G17-L11	A	CATN7-16-XB-D1DB-R17-L11	L
	3	2	1	CATN7-16-XB-D1DB-G17-L11	A	CATN7-16-XB-D1DB-R17-L11	L
1	5	2	1	CATN7-37-XB-D1ED-G17-L11	A	CATN7-37-XB-D1ED-R17-L11	L
	7.5	2	1	CATN7-37-XB-D1ED-G17-L11	A	CATN7-37-XB-D1ED-R17-L11	L
2	10	2	1	CATN7-43-XB-D1FD-G17-L11	A	CATN7-43-XB-D1FD-R17-L11	L
	15	2	1	CATN7-43-XB-D1FD-G17-L11	A	CATN7-43-XB-D1FD-R17-L11	L
3	20	2	1	CATN7-85-XB-EGE-G17-L11	B	CATN7-85-XB-EGE-R17-L11	M
	25	2	1	CATN7-85-XB-EGE-G17-L11	B	CATN7-85-XB-EGE-R17-L11	M
	30	2	1	CATN7-85-XB-EGE-G17-L11	B	CATN7-85-XB-EGE-R17-L11	M

Full Voltage Non-Reversing (FVNR) Features include:

- NEMA-sized CAN7 contactor
- Three-Phase CEP7 Electronic Overload Relay
- Control Circuit Transformer
- Hand-Off-Auto (H-O-A) selector switch
- Red Run pilot light
- 2-NO and 1-NC auxiliaries for customer use
- Class CC Fuse holder as fused primary of CCT
- Reset pushbutton

① HP and NEMA size selection shown for 208V ratings only. Contact your Sprecher + Schuh representative for other voltage applications.
 ② Contactors are equipped with number and type of auxiliaries indicated. See page C108 to order additional or different auxiliary contacts.
 ③ Dimensional information starts on page C122.
 ④ HP and NEMA size selection shown for 230V ratings only. Contact your Sprecher + Schuh representative for other voltage applications.

Three Phase, Non-Reversing CATN7 @460V AC Non-Combination Starter

NEMA Size	Max HP 3-Phase ④	Auxiliary Contacts per Contactor ②		Type 1 Metallic General Purpose	DIM	Type 3R Metallic Outdoor Raintight	DIM
		NO	NC	Catalog Number		Catalog Number	
00	0.25	2	1	CATN7-12-XC-D1BB-G17-L11	A	CATN7-12-XC-D1BB-R17-L11	L
	0.5	2	1	CATN7-12-XC-D1CB-G17-L11	A	CATN7-12-XC-D1CB-R17-L11	L
	0.75	2	1	CATN7-12-XC-D1CB-G17-L11	A	CATN7-12-XC-D1CB-R17-L11	L
	1	2	1	CATN7-12-XC-D1CB-G17-L11	A	CATN7-12-XC-D1CB-R17-L11	L
	1.5	2	1	CATN7-12-XC-D1CB-G17-L11	A	CATN7-12-XC-D1CB-R17-L11	L
	2	2	1	CATN7-12-XC-D1CB-G17-L11	A	CATN7-12-XC-D1CB-R17-L11	L
0	3	2	1	CATN7-16-XC-D1DB-G17-L11	A	CATN7-16-XC-D1DB-R17-L11	L
	5	2	1	CATN7-16-XC-D1DB-G17-L11	A	CATN7-16-XC-D1DB-R17-L11	L
1	7.5	2	1	CATN7-37-XC-D1ED-G17-L11	A	CATN7-37-XC-D1ED-R17-L11	L
	10	2	1	CATN7-37-XC-D1ED-G17-L11	A	CATN7-37-XC-D1ED-R17-L11	L
2	15	2	1	CATN7-43-XC-D1FD-G17-L11	A	CATN7-43-XC-D1FD-R17-L11	L
	20	2	1	CATN7-43-XC-D1FD-G17-L11	A	CATN7-43-XC-D1FD-R17-L11	L
	25	2	1	CATN7-43-XC-D1FD-G17-L11	A	CATN7-43-XC-D1FD-R17-L11	L
3	30	2	1	CATN7-85-XC-EGE-G17-L11	B	CATN7-85-XC-EGE-R17-L11	M
	40	2	1	CATN7-85-XC-EGE-G17-L11	B	CATN7-85-XC-EGE-R17-L11	M
	50	2	1	CATN7-85-XC-EGE-G17-L11	B	CATN7-85-XC-EGE-R17-L11	M

Full Voltage Non-Reversing (FVNR) Features include:

- NEMA-sized CAN7 contactor
- Three-Phase CEP7 Electronic Overload Relay
- Control Circuit Transformer
- Hand-Off-Auto (H-O-A) selector switch
- Red Run pilot light
- 2-NO and 1-NC auxiliaries for customer use
- Class CC Fuse holder as fused primary of CCT
- Reset pushbutton

NEMA Non-Combination Starters

See new NEMA Starters Section starting at page 101.1

This page has moved.

Three Phase, Non-Reversing CATN7 @575V AC Non-Combination Starter

NEMA Size	Max HP 3-Phase ④	Auxiliary Contacts per Contactor ②		Type 1 Metallic General Purpose	DIM	Type 3R Metallic Outdoor Raintight	DIM
		NO	NC	Catalog Number		Catalog Number	
00	0.25	2	1	CATN7-12-XD-D1BB-G17-L11	A	CATN7-12-XD-D1BB-R17-L11	L
	0.5	2	1	CATN7-12-XD-D1CB-G17-L11	A	CATN7-12-XD-D1CB-R17-L11	L
	0.75	2	1	CATN7-12-XD-D1CB-G17-L11	A	CATN7-12-XD-D1CB-R17-L11	L
	1	2	1	CATN7-12-XD-D1CB-G17-L11	A	CATN7-12-XD-D1CB-R17-L11	L
	2	2	1	CATN7-12-XD-D1CB-G17-L11	A	CATN7-12-XD-D1CB-R17-L11	L
	3	2	1	CATN7-16-XD-D1DB-G17-L11	A	CATN7-16-XD-D1DB-R17-L11	L
0	5	2	1	CATN7-16-XD-D1DB-G17-L11	A	CATN7-16-XD-D1DB-R17-L11	L
	7.5	2	1	CATN7-37-XD-D1ED-G17-L11	A	CATN7-37-XD-D1ED-R17-L11	L
1	10	2	1	CATN7-37-XD-D1ED-G17-L11	A	CATN7-37-XD-D1ED-R17-L11	L
	15	2	1	CATN7-43-XD-D1FD-G17-L11	A	CATN7-43-XD-D1FD-R17-L11	L
2	20	2	1	CATN7-43-XD-D1FD-G17-L11	A	CATN7-43-XD-D1FD-R17-L11	L
	25	2	1	CATN7-43-XD-D1FD-G17-L11	A	CATN7-43-XD-D1FD-R17-L11	L
	30	2	1	CATN7-85-XD-EGE-G17-L11	B	CATN7-85-XD-EGE-R17-L11	M
3	40	2	1	CATN7-85-XD-EGE-G17-L11	B	CATN7-85-XD-EGE-R17-L11	M
	50	2	1	CATN7-85-XD-EGE-G17-L11	B	CATN7-85-XD-EGE-R17-L11	M

Full Voltage Non-Reversing (FVNR) Features include:

- NEMA-sized CAN7 contactor
- Three-Phase CEP7 Electronic Overload Relay
- Control Circuit Transformer
- Hand-Off-Auto (H-O-A) selector switch
- Red Run pilot light
- 2-NO and 1-NC auxiliaries for customer use
- Class CC Fuse holder as fused primary of CCT
- Reset pushbutton

- ① HP and NEMA size selection shown for 460V ratings only. Contact your Sprecher + Schuh representative for other voltage applications.
- ② Contactors are equipped with number and type of auxiliaries indicated. See page C108 to order additional or different auxiliary contacts.
- ③ Dimensional information starts on page C122.
- ④ HP and NEMA size selection shown for 575V ratings only. Contact your Sprecher + Schuh representative for other voltage applications.

Single Phase, Non-Reversing CBTN7

NEMA Size	Maximum HP Single ϕ		Auxiliary Contacts per Contactor $\text{\textcircled{e}}$		Open Type	Type 1 General Purpose	D I M	Type 12 [Type 3R $\text{\textcircled{e}}$] Industrial Dusttight	D I M
	115V	230V	NO	NC					
00	1/3	1	1	0	CBTN7-12-* $\text{\textcircled{d}}$	CBTN7-12-* $\text{\textcircled{d}}$ -G0	A	CBTN7-12-* $\text{\textcircled{d}}$ -D0	L
0	1	2	1	0	CBTN7-16-* $\text{\textcircled{d}}$	CBTN7-16-* $\text{\textcircled{d}}$ -G0	A	CBTN7-16-* $\text{\textcircled{d}}$ -D0	L
1	2	3	1	0	CBTN7-37-* $\text{\textcircled{d}}$	CBTN7-37-* $\text{\textcircled{d}}$ -G0	A	CBTN7-37-* $\text{\textcircled{d}}$ -D0	L
2	3	7-1/2	1	0	CBTN7-43-* $\text{\textcircled{d}}$	CBTN7-43-* $\text{\textcircled{d}}$ -G0	A	CBTN7-43-* $\text{\textcircled{d}}$ -D0	L
3	7-1/2	15	1	0	CBTN7-85-* $\text{\textcircled{d}}$	CBTN7-85-* $\text{\textcircled{d}}$ -G0	B	CBTN7-85-* $\text{\textcircled{d}}$ -D0	M

Single Phase, Non-Reversing CBTN7

NEMA Size	Maximum HP Single ϕ		Auxiliary Contacts per Contactor $\text{\textcircled{e}}$		Type 4 Watertight	D I M	Type 4X Watertight Corrosion Resistant Non-metallic	D I M
	115V	230V	NO	NC				
00	1/3	1	1	0	CBTN7-12-* $\text{\textcircled{d}}$ -W0	N	CBTN7-12-* $\text{\textcircled{d}}$ -C0	S1
0	1	2	1	0	CBTN7-16-* $\text{\textcircled{d}}$ -W0	N	CBTN7-16-* $\text{\textcircled{d}}$ -C0	S1
1	2	3	1	0	CBTN7-37-* $\text{\textcircled{d}}$ -W0	N	CBTN7-37-* $\text{\textcircled{d}}$ -C0	U1
2	3	7-1/2	1	0	CBTN7-43-* $\text{\textcircled{d}}$ -W0	N	CBTN7-43-* $\text{\textcircled{d}}$ -C0	U1
3	7-1/2	15	1	0	CBTN7-85-* $\text{\textcircled{d}}$ -W0	O	CBTN7-85-* $\text{\textcircled{d}}$ -C0	U1

This page has moved.
 See new NEMA Starters Section starting at page 101.1

NOTE: Catalog numbers and enclosure dimensions reflect contactors with AC coils. For DC coils, select Coil Code from the DC Coil Code table on page C104 and follow the instructions for modifying catalog numbers.

Ordering Instructions

Specify Catalog Number	
Replace (*) with Coil Code	See page C104
Replace $\text{\textcircled{d}}$ with O/L Relay	See pages C105-C106
Factory Modifications available	See pages C107-C111

- $\text{\textcircled{i}}$ Dimensional information starts on page C122.
- $\text{\textcircled{e}}$ For Type 3R outdoor applications, replace "D" in catalog number with an "R". Dimensions may change. For example number CBTN7-37-* $\text{\textcircled{d}}$ -D0 becomes CBTN7-37-* $\text{\textcircled{d}}$ -R0.
- $\text{\textcircled{e}}$ Contactors are equipped with number and type of auxiliaries indicated. See page C108 to order additional or different auxiliary contacts.

Single Phase, Non-Reversing CBTN7 @ 120V AC Non-Combination

NEMA Size	Max HP 1-Phase ①	Auxiliary Contacts per Contactor ②		Type 1 Metallic General Purpose	DIM	Type 3R Metallic Outdoor Raintight	DIM
		NO	NC	Catalog No.		③ Catalog No.	
00	0.33	2	1	CBTN7-12-120-ERB-G17-L11	A	CBTN7-12-120-ERB-R17-L11	L
	0.5	2	1	CBTN7-16-120-ESB-G17-L11	A	CBTN7-16-120-ESB-R17-L11	L
0	0.75	2	1	CBTN7-16-120-ESB-G17-L11	A	CBTN7-16-120-ESB-R17-L11	L
	1	2	1	CBTN7-16-120-ESB-G17-L11	A	CBTN7-16-120-ESB-R17-L11	L
1	1.5	2	1	CBTN7-37-120-ETD-G17-L11	A	CBTN7-37-120-ETD-R17-L11	L
	2	2	1	CBTN7-37-120-ETD-G17-L11	A	CBTN7-37-120-ETD-R17-L11	L
2	3	2	1	CBTN7-43-120-ETD-G17-L11	A	CBTN7-43-120-ETD-R17-L11	L
3	5	2	1	CBTN7-85-120-EUE-G17-L11	B	CBTN7-85-120-EUE-R17-L11	M
	7.5	2	1	CBTN7-85-120-EUE-G17-L11	B	CBTN7-85-120-EUE-R17-L11	M

Full Voltage Non-Reversing (FVNR) Features include:

- NEMA-sized CAN7 contactor
- Single-Phase CEP7S electronic overload relay
- AC coil
- Hand-Off-Auto (H-O-A) selector switch
- Red Run pilot light
- 2-NO and 1-NC auxiliaries for customer use
- Reset pushbutton

NEMA Non-Combination Starters

NEMA Size	Max HP 1-Phase ①	Auxiliary Contacts per Contactor ②		Type 1 Metallic General Purpose	DIM	Type 3R Metallic Outdoor Raintight	DIM
		NO	NC	Catalog No.		③ Catalog No.	
00	0.25	2	1	CBTN7-12-220W-EPB-G17-L11	A	CBTN7-12-220W-EPB-R17-L11	L
	0.5	2	1	CBTN7-12-220W-EPB-G17-L11	A	CBTN7-12-220W-EPB-R17-L11	L
	0.75	2	1	CBTN7-12-220W-EPB-G17-L11	A	CBTN7-12-220W-EPB-R17-L11	L
	1	2	1	CBTN7-12-220W-EPB-G17-L11	A	CBTN7-12-220W-EPB-R17-L11	L
0	1.5	2	1	CBTN7-16-220W-ESB-G17-L11	A	CBTN7-16-220W-ESB-R17-L11	L
	2	2	1	CBTN7-16-220W-ESB-G17-L11	A	CBTN7-16-220W-ESB-R17-L11	L
1	3	2	1	CBTN7-37-220W-ETD-G17-L11	A	CBTN7-37-220W-ETD-R17-L11	L
2	5	2	1	CBTN7-43-220W-ETD-G17-L11	A	CBTN7-43-220W-ETD-R17-L11	L
	7.5	2	1	CBTN7-43-220W-ETD-G17-L11	A	CBTN7-43-220W-ETD-R17-L11	L
3	10	2	1	CBTN7-85-220W-EUE-G17-L11	B	CBTN7-85-220W-EUE-R17-L11	M
	15	2	1	CBTN7-85-220W-EUE-G17-L11	B	CBTN7-85-220W-EUE-R17-L11	M

See new NEMA Starters Section starting at page 101.1

Full Voltage Non-Reversing (FVNR) Features include:

- NEMA-sized CAN7 contactor
- Single-Phase CEP7S electronic overload relay
- AC coil
- Hand-Off-Auto (H-O-A) selector switch
- Red Run pilot light
- 2-NO and 1-NC auxiliaries for customer use
- Reset pushbutton

- ① HP and NEMA size selection shown for 120V ratings only. Contact your Sprecher + Schuh representative for other voltage applications.
- ② Contactors are equipped with number and type of auxiliaries indicated. See page C108 to order additional or different auxiliary contacts.
- ③ Dimensional information starts on page C122.
- ④ HP and NEMA size selection shown for 230V ratings only. Contact your Sprecher + Schuh representative for other voltage applications.

Combination Starters - Through the Door Operated

Smart and cost effective... for any application

Combination Starters



Sprecher + Schuh's through-the-door operated combination starters represent an economical alternative to the classic flange-operated combo solution. It is designed to meet rigid UL/NEC withstand specifications. Sprecher + Schuh has been building custom control panels with this design for years. Experience the durability of this product!

Starting with the best

At the heart of all combination starters is the Sprecher + Schuh CAT7 and CAT9 line of motor starters. These starters are compact and offer intermediate sizes to better match specific motor requirements. This equates to generous wiring space and less wasted horsepower capacity.

Top line protection...

Combination starters are equipped with Sprecher + Schuh's premium CEP7 solid state overload relay standard. Unlike traditional overload relays that indirectly sense motor current through heater elements, CEP7 solid state overload relays measure motor current directly through integrated current transformers and on board electronics. The electronics provide numerous advantages over electromechanical relays. Alternatively, the CT7N Thermal Overload Relay may also be selected.

Choice of Enclosures

Available enclosures include;

- Type 1 General Purpose
- Type 3R Raintight
- Type 12 Dusttight
- Type 4 Watertight
- Type 4X Corrosion Resistant

Choice of Disconnect

- Choices for disconnect include:
- Thermal Magnetic Molded Case Circuit Breaker (MCCB)
- L11 fusible or non-fusible Disconnect switch
- Motor Circuit Controller (Section F)

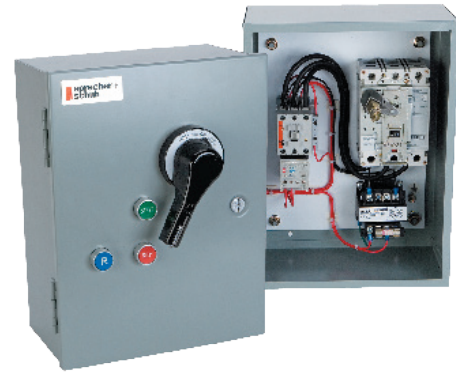

Thermal Magnetic Molded Case Circuit Breaker (MCCB)

The through-the-door operated combo MCCB is available to meet UL short circuit withstand specifications. An MCCB prevents single phasing by simultaneously opening all three phases when a fault occurs in any one phase. An MCCB can often be reset after the fault has been cleared.

Disconnect Switches

The through-the-door operated combo is available with the L11 disconnect switch. A mechanical door interlock system prevents the door from being opened when the disconnect is closed, and conversely, prevents the disconnect from being closed when the door is open. Both functions can be defeated for test and maintenance purposes. Other safety features include padlock provisions and a high visibility operating handle.

The L11 disconnect switch has a quick make/quick break, non-teasing action. The L11 fusible switch is suitable for interrupting up to 100,000 amperes when class "J" fuses are used. All L11 disconnect switches conform to UL 98 standards.

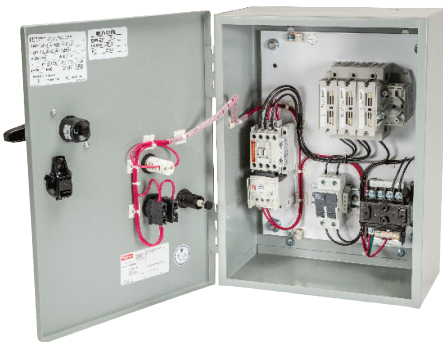

Series CAT7 with Thermal-Magnetic Circuit Breaker ①

Maximum Horsepower Three Phase				MCCB Amps	Open Type Catalog No. ②
200V	230V	460V	575V		
2	2	5	~	15	CAT7-9-*◆-TB15-BP
2	2	5	5	15	CAT7-9-*◆-TBH15-BP
~	~	~	7.5	20	CAT7-9-*◆-TBH20-BP
3	3	7.5	~	20	CAT7-12-*◆-TB20-BP
3	3	7.5	10	20	CAT7-12-*◆-TBH20-BP
~	5	10	~	30	CAT7-16-*◆-TB30-BP
5	~	~	~	35	CAT7-23-*◆-TB35-BP
5	~	~	15	35	CAT7-23-*◆-TBH35-BP
~	7.5	15	~	40	CAT7-23-*◆-TB40-BP
~	~	~	20	40	CAT7-30-*◆-TBH40-BP
7.5	10	20	25 ③	50	CAT7-30-*◆-TB50-BP
7.5	10	20	25	50	CAT7-30-*◆-TBH50-BP
10	10	25	30 ③	50	CAT7-37-*◆-TB50-BP
10	10	~	30	50	CAT7-37-*◆-TBH50-BP
~	~	30	~	70	CAT7-43-*◆-TB70-BP
~	15	~	~	80	CAT7-43-*◆-TB80-BP
15	20	40	40 ③	80	CAT7-55-*◆-TB80-BP
15	20	40	40	80	CAT7-55-*◆-TBH80-BP
~	~	~	40 ③	80	CAT7-60-*◆-TB80-BP
~	~	~	40	80	CAT7-60-*◆-TBH80-BP
15	20	40	50 ③	100	CAT7-60-*◆-TB100-BP
15	20	40	50	100	CAT7-60-*◆-TBH100-BP
20	25	50	60 ③	125	CAT7-72-*◆-TB125-BP
~	25	~	60	125	CAT7-72-*◆-TBH125-BP
25	30	60	~	125	CAT7-85-*◆-TB125-BP
~	30	~	75 ③	125	CAT7-97-*◆-TB125-BP
~	30	~	75	125	CAT7-97-*◆-TBH125-BP

Larger sizes available. Contact your Sprecher + Schuh representative.

Modifications (Factory Assembled) ①

Description	Add Suffix to Catalog Number
CA7 Auxiliaries & Trip Contacts - Side Mount	1 NO Auxiliary
	1 NC Auxiliary
1 NO + 1 NC Auxiliary	2 NO Auxiliaries
	2 NC Auxiliaries



Open Combination Starters include the following:

- CA7 Contactor with 1 Normally Open Auxiliary contact
- CEP7 Overload Relay
- Thermal Magnetic Circuit Breaker
- 19 x 5.25" 12 gauge steel back pan with black polyester powder paint finish

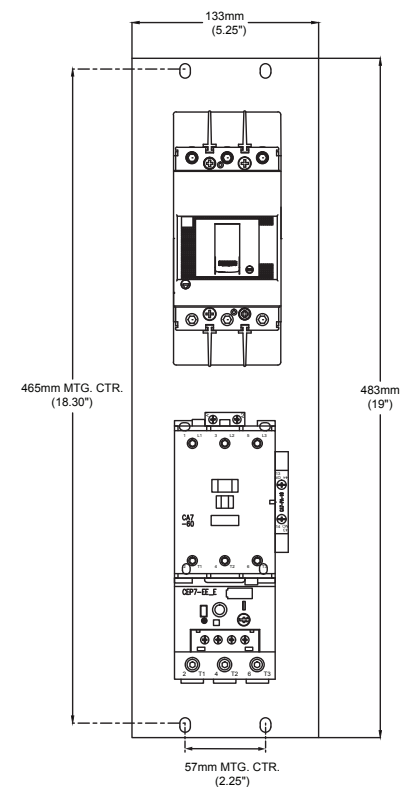

NOTE: Catalog numbers and enclosure dimensions reflect contactors with AC coils. For DC coils, select Coil Code from the DC Coil Code table on page C104 and follow the instructions for modifying Catalog Numbers.

- ① Open type combination starters are limited to standard coils, overload selections, and modifications listed on this page. Contact factory for additional modifications.
- ② Applicable to 600Y/347V only. Refer to page C61 for 600V Delta enclosed solution. Contact your Sprecher + Schuh representative for an open type delta solution.
- ③ Selections above the orange line should consider an E-Combo starter. See page F58.

Ordering Instructions

Specify Catalog Number	
Replace (*) with Coil Code	See page C104
Replace (◆) with O/L Relay	See pages C105-C106

Series CAT7 & CAT9 with Thermal-Magnetic Circuit Breaker

Maximum Horsepower Three Phase				MCCB Amps	Type 1 General Purpose Catalog No.	D I M	Type 12 [Type 3R ☉] Industrial Dusttight Catalog No.	D I M	Type 4 Watertight Catalog No.	D I M	Type 4X Watertight Corrosion Resistant Non-metallic Catalog No.	D I M
200V	230V	460V	575V									
2	2	5	~	15	7-9-*◆-TB15G0	C2	7-9-*◆-TB15D0	C3	7-9-*◆-TB15W0	C2	7-9-*◆-TB15C0	V2
3	3	7.5	~	20	7-12-*◆-TB20G0	C2	7-12-*◆-TB20D0	C3	7-12-*◆-TB20W0	C2	7-12-*◆-TB20C0	V2
~	5	10	~	30	7-16-*◆-TB30G0	C2	7-16-*◆-TB30D0	C3	7-16-*◆-TB30W0	C2	7-16-*◆-TB30C0	V2
5	~	~	~	35	7-23-*◆-TB35G0	C2	7-23-*◆-TB35D0	C3	7-23-*◆-TB35W0	C2	7-23-*◆-TB35C0	V2
~	7.5	15	~	40	7-23-*◆-TB40G0	C2	7-23-*◆-TB40D0	C3	7-23-*◆-TB40W0	C2	7-23-*◆-TB40C0	V2
~	~	~	20 ☉	40	7-30-*◆-TB40G0	C2	7-30-*◆-TB40D0	C3	7-30-*◆-TB40W0	C2	7-30-*◆-TB40C0	V2
7.5	10	20	25 ☉	50	7-30-*◆-TB50G0	C2	7-30-*◆-TB50D0	C3	7-30-*◆-TB50W0	C2	7-30-*◆-TB50C0	V2
10	~	25	30 ☉	60	7-37-*◆-TB60G0	C2	7-37-*◆-TB60D0	C3	7-37-*◆-TB60W0	C2	7-37-*◆-TB60C0	V2
~	~	30	~	70	7-43-*◆-TB70G0	C2	7-43-*◆-TB70D0	C3	7-43-*◆-TB70W0	C2	7-43-*◆-TB70C0	V2
~	15	~	~	80	7-43-*◆-TB80G0	C2	7-43-*◆-TB80D0	C3	7-43-*◆-TB80W0	C2	7-43-*◆-TB80C0	V2
15	20	40	40 ☉	80	7-55-*◆-TB80G0	C2	7-55-*◆-TB80D0	C3	7-55-*◆-TB80W0	C2	7-55-*◆-TB80C0	V2
~	~	~	40 ☉	80	7-60-*◆-TB80G0	D3	7-60-*◆-TB80D0	Q	7-60-*◆-TB80W0	Q	7-60-*◆-TB80C0	W2
15	20	40	50 ☉	100	7-60-*◆-TB100G0	D3	7-60-*◆-TB100D0	Q	7-60-*◆-TB100W0	Q	7-60-*◆-TB100C0	W2
20	25	50	60 ☉	125	7-72-*◆-TB125G0	D3	7-72-*◆-TB125D0	Q	7-72-*◆-TB125W0	Q	7-72-*◆-TB125C0	W2
25	30	60	~	125	7-85-*◆-TB125G0	D3	7-85-*◆-TB125D0	Q	7-85-*◆-TB125W0	Q	7-85-*◆-TB125C0	W2
~	~	~	75 ☉☉	150	7-97-*◆-TB150G0	D3	7-97-*◆-TB150D0	Q	7-97-*◆-TB150W0	Q	7-97-*◆-TB150C0	W2
30 ☉	~	75 ☉	~	175	7-97-*◆-TB175G0	D3	7-97-*◆-TB175D0	Q	7-97-*◆-TB175W0	Q	7-97-*◆-TB175C0	W2
30	~	75	~	175	9-116-*◆-TB175G0 ☉	E2	9-116-*◆-TB175D0 ☉	R2	9-116-*◆-TB175W0 ☉	R2	9-116-*◆-TB175C0 ☉	X1
~	40	~	100 ☉	200	9-116-*◆-TB200G0 ☉	E2	9-116-*◆-TB200D0 ☉	R2	9-116-*◆-TB200W0 ☉	R2	9-116-*◆-TB200C0 ☉	X1
40	~	100	125 ☉	225	9-146-*◆-TB225G0 ☉	G	9-146-*◆-TB225D0 ☉	R2	9-146-*◆-TB225W0 ☉	R2	9-146-*◆-TB225C0 ☉	X1
~	50	~	~	250	9-146-*◆-TB250G0 ☉	G	9-146-*◆-TB250D0 ☉	T	9-146-*◆-TB250W0 ☉	T	9-146-*◆-TB250C0 ☉	X1
50	60	125	150	300	9-190-*◆-TB300G0 ☉	H	9-190-*◆-TB300D0 ☉	T	9-190-*◆-TB300W0 ☉	T	9-190-*◆-TB300C0 ☉	X1
60	75	150	200	350	9-205-*◆-TB350G0 ☉	H	9-205-*◆-TB350D0 ☉	H	9-205-*◆-TB350W0 ☉	H	9-205-*◆-TB350C0 ☉	A2
75	~	175	~	400	9-265-*◆-TB400G0 ☉	H	9-265-*◆-TB400D0 ☉	H	9-265-*◆-TB400W0 ☉	H	9-265-*◆-TB400C0 ☉	A2
~	100	200	250	450	9-265-*◆-TB450G0 ☉	H	9-265-*◆-TB450D0 ☉	H	9-265-*◆-TB450W0 ☉	H	9-265-*◆-TB450C0 ☉	Y1
100	~	~	~	500	9-305-*◆-TB500G0 ☉	I	9-305-*◆-TB500D0 ☉	W	9-305-*◆-TB500W0 ☉	J	9-305-*◆-TB500C0 ☉	Y1
~	125	250	300	600	9-305-*◆-TB600G0 ☉	I	9-305-*◆-TB600D0 ☉	W	9-305-*◆-TB600W0 ☉	J	9-305-*◆-TB600C0 ☉	Y1
~	~	~	350	600	9-370-*◆-TB600G0 ☉	I	9-370-*◆-TB600D0 ☉	W	9-370-*◆-TB600W0 ☉	J	9-370-*◆-TB600C0 ☉	Y1
125	150	300	~	700	9-370-*◆-TB700G0 ☉	I	9-370-*◆-TB700D0 ☉	W	9-370-*◆-TB700W0 ☉	J	9-370-*◆-TB700C0 ☉	Y1
125	150	~	400	700	9-400-EI-*◆-TB700G0	J	9-400-EI-*◆-TB700D0	J	9-400-EI-*◆-TB700W0	J	9-400-EI-*◆-TB700C0	Y1
~	~	350	~	800	9-400-EI-*◆-TB800G0	J	9-400-EI-*◆-TB800D0	J	9-400-EI-*◆-TB800W0	J	9-400-EI-*◆-TB800C0	Y1
150	~	~	~	800	9-460-EI-*◆-TB800G0	J	9-460-EI-*◆-TB800D0	J	9-460-EI-*◆-TB800W0	J	9-460-EI-*◆-TB800C0	Y1
~	200	400	500	1000	9-460-EI-*◆-TB1000G0	J	9-460-EI-*◆-TB1000D0	J	9-460-EI-*◆-TB1000W0	J	9-460-EI-*◆-TB1000C0	Y1
200	~	~	600	1000	9-580-EI-*◆-TB1000G0	R/F	9-580-EI-*◆-TB1000D0	R/F	9-580-EI-*◆-TB1000W0	R/F	9-580-EI-*◆-TB1000C0	R/F
~	250	500	~	1200	9-580-EI-*◆-TB1200G0	R/F	9-580-EI-*◆-TB1200D0	R/F	9-580-EI-*◆-TB1200W0	R/F	9-580-EI-*◆-TB1200C0	R/F

Larger sizes available. Contact your Sprecher + Schuh representative.

NOTE: Catalog numbers and enclosure dimensions reflect contactors with AC coils. For DC coils, select Coil Code from the DC Coil Code table on page C104 and follow the instructions for modifying catalog numbers.

- ① Dimensional information starts on page C122.
- ② For Type 3R outdoor applications, replace "D" in catalog number with an "R". Dimensions may change. For example number CAT7-30-*◆-TB50D0 becomes CAT7-30-*◆-TB50R0.
- ③ Applicable to 600Y/347V only. Refer to page C61 for 600V Delta solution.
- ④ The short circuit and kAIC is relegated to the contactor's 10kA. Contact your Sprecher + Schuh representative for a higher kAIC.
- ⑤ CAT9-116...CAT9-370 starters are available with "EI" option for PLC interface. Change catalog number to include "-EI". Example: CAT9-116-*◆-TB175G0 becomes CAT9-116-EI-*◆-TB175G0.

Ordering Instructions

Specify Catalog Number	
Replace (*) with Coil Code	See page C104
Replace (◆) with O/L Relay	See pages C105-C106
Factory Modifications available	See pages C107-C111

Series CAT7 & CAT9 with Thermal-Magnetic Circuit Breaker - 600V Delta

Maximum Horsepower Three Phase				MCCB Amps	Type 1 General Purpose	D I M	Type 12 [Type 3R ☉] Industrial Dusttight	D I M	Type 4 Watertight	D I M	Type 4X Watertight Corrosion Resistant Non-metallic	D I M
200V	230V	460V	575V		Catalog No.		☉ Catalog No.		☉ Catalog No.		☉ Catalog No.	
					CAT		CAT		CAT		CAT	
2	2	5	5	15	7-9-☉-TBH15G0	C2	7-9-☉-TBH15D0	C3	7-9-☉-TBH15W0	C2	7-9-☉-TBH15C0	V2
~	~	~	7.5	20	7-9-☉-TBH20G0	C2	7-9-☉-TBH20D0	C3	7-9-☉-TBH20W0	C2	7-9-☉-TBH20C0	V2
3	3	7.5	10	20	7-12-☉-TBH20G0	C2	7-12-☉-TBH20D0	C3	7-12-☉-TBH20W0	C2	7-12-☉-TBH20C0	V2
5	~	~	15	35	7-23-☉-TBH35G0	C2	7-23-☉-TBH35D0	C3	7-23-☉-TBH35W0	C2	7-23-☉-TBH35C0	V2
~	~	~	20	40	7-30-☉-TBH40G0	C2	7-30-☉-TBH40D0	C3	7-30-☉-TBH40W0	C2	7-30-☉-TBH40C0	V2
7.5	10	20	25	50	7-30-☉-TBH50G0	C2	7-30-☉-TBH50D0	C3	7-30-☉-TBH50W0	C2	7-30-☉-TBH50C0	V2
10	~	25	30	60	7-37-☉-TBH60G0	C2	7-37-☉-TBH60D0	C3	7-37-☉-TBH60W0	C2	7-37-☉-TBH60C0	V2
15	20	40	40	80	7-55-☉-TBH80G0	C2	7-55-☉-TBH80D0	C3	7-55-☉-TBH80W0	C2	7-55-☉-TBH80C0	V2
~	~	~	40	80	7-60-☉-TBH80G0	D3	7-60-☉-TBH80D0	Q	7-60-☉-TBH80W0	Q	7-60-☉-TBH80C0	W2
15	20	40	50	100	7-60-☉-TBH100G0	D3	7-60-☉-TBH100D0	Q	7-60-☉-TBH100W0	Q	7-60-☉-TBH100C0	W2
~	25	~	60	125	7-72-☉-TBH125G0	D3	7-72-☉-TBH125D0	Q	7-72-☉-TBH125W0	Q	7-72-☉-TBH125C0	W2
~	~	~	75 ☉	150	7-97-☉-TBH150G0	D3	7-97-☉-TBH150D0	Q	7-97-☉-TBH150W0	Q	7-97-☉-TBH150C0	W2
30	~	75	~	175	9-116-☉-TBH175G0 ☉	E2	9-116-☉-TBH175D0 ☉	R2	9-116-☉-TBH175W0 ☉	R2	9-116-☉-TBH175C0 ☉	X1
~	40	~	100 ☉	200	9-116-☉-TBH200G0 ☉	E2	9-116-☉-TBH200D0 ☉	R2	9-116-☉-TBH200W0 ☉	R2	9-116-☉-TBH200C0 ☉	X1
40	~	100	125 ☉	225	9-146-☉-TBH225G0 ☉	G	9-146-☉-TBH225D0 ☉	T	9-146-☉-TBH225W0 ☉	T	9-146-☉-TBH225C0 ☉	X1

C
Combination Starters

Ordering Instructions

Specify Catalog Number	
Replace (*) with Coil Code	See page C104
Replace (◆) with O/L Relay	See pages C105-C106
Factory Modifications available	See pages C107-C111

NOTE: Catalog numbers and enclosure dimensions reflect contactors with AC coils. For DC coils, select Coil Code from the DC Coil Code table on page C104 and follow the instructions for modifying catalog numbers.

- ① Dimensional information starts on page C122.
- ② For Type 3R outdoor applications, replace "D" in catalog number with an "R". Dimensions may change. For example number CAT7-30-☉-TBH50D0 becomes CAT7-30-☉-TBH50R0.
- ③ The short circuit and kAIC is relegated to the contactor's 10kA. Contact your Sprecher + Schuh representative for a higher kAIC.
- ④ CAT9-116...CAT9-370 starters are available with "EI" option for PLC interface. Change catalog number to include "-EI". Example: CAT9-116-☉-TBH175G0 becomes CAT9-116-EI-☉-TBH175G0.

Series CAUT7 & CAUT9 with Thermal-Magnetic Circuit Breaker

Maximum Horsepower Three Phase				MCCB Amps	Type 1 General Purpose	D I M	Type 12 [Type 3R Ⓜ] Industrial Dusttight	D I M	Type 4 Watertight	D I M	Type 4X Watertight Corrosion Resistant Non-metallic	D I M
200V	230V	460V	575V		Catalog No.	Ⓜ	Catalog No.	Ⓜ	Catalog No.	Ⓜ	Catalog No.	Ⓜ
					CAUT		CAUT		CAUT		CAUT	
2	2	5	~	15	7-9- * - ◆ -TB15G0	D3	7-9- * - ◆ -TB15D0	Q	7-9- * - ◆ -TB15W0	Q	7-9- * - ◆ -TB15C0	V2
3	3	7.5	~	20	7-12- * - ◆ -TB20G0	D3	7-12- * - ◆ -TB20D0	Q	7-12- * - ◆ -TB20W0	Q	7-12- * - ◆ -TB20C0	V2
~	5	10	~	30	7-16- * - ◆ -TB30G0	D3	7-16- * - ◆ -TB30D0	Q	7-16- * - ◆ -TB30W0	Q	7-16- * - ◆ -TB30C0	V2
5	~	~	~	35	7-23- * - ◆ -TB35G0	D3	7-23- * - ◆ -TB35D0	Q	7-23- * - ◆ -TB35W0	Q	7-23- * - ◆ -TB35C0	V2
~	7.5	15	~	40	7-23- * - ◆ -TB40G0	D3	7-23- * - ◆ -TB40D0	Q	7-23- * - ◆ -TB40W0	Q	7-23- * - ◆ -TB40C0	V2
~	~	~	20 Ⓜ	40	7-30- * - ◆ -TB40G0	D3	7-30- * - ◆ -TB40D0	Q	7-30- * - ◆ -TB40W0	Q	7-30- * - ◆ -TB40C0	V2
7.5	10	20	25 Ⓜ	50	7-30- * - ◆ -TB50G0	D3	7-30- * - ◆ -TB50D0	Q	7-30- * - ◆ -TB50W0	Q	7-30- * - ◆ -TB50C0	V2
10	~	25	30 Ⓜ	60	7-37- * - ◆ -TB60G0	D3	7-37- * - ◆ -TB60D0	Q	7-37- * - ◆ -TB60W0	Q	7-37- * - ◆ -TB60C0	V2
~	~	30	~	70	7-43- * - ◆ -TB70G0	D3	7-43- * - ◆ -TB70D0	Q	7-43- * - ◆ -TB70W0	Q	7-43- * - ◆ -TB70C0	V2
~	15	~	~	80	7-43- * - ◆ -TB80G0	D3	7-43- * - ◆ -TB80D0	Q	7-43- * - ◆ -TB80W0	Q	7-43- * - ◆ -TB80C0	V2
15	20	40	40 Ⓜ	80	7-55- * - ◆ -TB80G0	D3	7-55- * - ◆ -TB80D0	Q	7-55- * - ◆ -TB80W0	Q	7-55- * - ◆ -TB80C0	V2
~	~	~	40 Ⓜ	80	7-60- * - ◆ -TB80G0	D3	7-60- * - ◆ -TB80D0	Q	7-60- * - ◆ -TB80W0	Q	7-60- * - ◆ -TB80C0	W2
20	25	50	60 Ⓜ	125	7-72- * - ◆ -TB125G0	D3	7-72- * - ◆ -TB125D0	Q	7-72- * - ◆ -TB125W0	Q	7-72- * - ◆ -TB125C0	W2
25	30	60	~	125	7-85- * - ◆ -TB125G0	D3	7-85- * - ◆ -TB125D0	Q	7-85- * - ◆ -TB125W0	Q	7-85- * - ◆ -TB125C0	W2
~	~	~	75 Ⓜ	150	7-97- * - ◆ -TB150G0	D3	7-97- * - ◆ -TB150D0	Q	7-97- * - ◆ -TB150W0	Q	7-97- * - ◆ -TB150C0	W2
30 Ⓜ	~	75 Ⓜ	~	125	7-97- * - ◆ -TB175G0	D3	7-97- * - ◆ -TB175D0	Q	7-97- * - ◆ -TB175W0	Q	7-97- * - ◆ -TB175C0	W2
30	~	75	~	175	9-116- * - ◆ -TB175G0 Ⓜ	E2	9-116- * - ◆ -TB175D0 Ⓜ	R2	9-116- * - ◆ -TB175W0 Ⓜ	R2	9-116- * - ◆ -TB175C0 Ⓜ	X1
~	40	~	100 Ⓜ	200	9-116- * - ◆ -TB200G0 Ⓜ	E2	9-116- * - ◆ -TB200D0 Ⓜ	R2	9-116- * - ◆ -TB200W0 Ⓜ	R2	9-116- * - ◆ -TB200C0 Ⓜ	X1
40	~	100	125 Ⓜ	225	9-146- * - ◆ -TB225G0 Ⓜ	G	9-146- * - ◆ -TB225D0 Ⓜ	T	9-146- * - ◆ -TB225W0 Ⓜ	T	9-146- * - ◆ -TB225C0 Ⓜ	X1
~	50	~	~	250	9-146- * - ◆ -TB250G0 Ⓜ	G	9-146- * - ◆ -TB250D0 Ⓜ	T	9-146- * - ◆ -TB250W0 Ⓜ	T	9-146- * - ◆ -TB250C0 Ⓜ	X1
50	60	125	150	300	9-190- * - ◆ -TB300G0 Ⓜ	H	9-190- * - ◆ -TB300D0 Ⓜ	H	9-190- * - ◆ -TB300W0 Ⓜ	H	9-190- * - ◆ -TB300C0 Ⓜ	A2
60	75	150	200	350	9-205- * - ◆ -TB350G0 Ⓜ	H	9-205- * - ◆ -TB350D0 Ⓜ	H	9-205- * - ◆ -TB350W0 Ⓜ	H	9-205- * - ◆ -TB350C0 Ⓜ	Y1
75	~	175	~	400	9-265- * - ◆ -TB400G0 Ⓜ	I	9-265- * - ◆ -TB400D0 Ⓜ	W	9-265- * - ◆ -TB400W0 Ⓜ	J	9-265- * - ◆ -TB400C0 Ⓜ	Y1
~	100	200	250	450	9-265- * - ◆ -TB450G0 Ⓜ	I	9-265- * - ◆ -TB450D0 Ⓜ	W	9-265- * - ◆ -TB450W0 Ⓜ	J	9-265- * - ◆ -TB450C0 Ⓜ	Y1
100	~	~	~	500	9-305- * - ◆ -TB500G0 Ⓜ	I	9-305- * - ◆ -TB500D0 Ⓜ	W	9-305- * - ◆ -TB500W0 Ⓜ	J	9-305- * - ◆ -TB500C0 Ⓜ	Y1
~	125	250	300	600	9-305- * - ◆ -TB600G0 Ⓜ	I	9-305- * - ◆ -TB600D0 Ⓜ	W	9-305- * - ◆ -TB600W0 Ⓜ	J	9-305- * - ◆ -TB600C0 Ⓜ	Y1
~	~	~	350	600	9-370- * - ◆ -TB600G0 Ⓜ	J	9-370- * - ◆ -TB600D0 Ⓜ	W	9-370- * - ◆ -TB600W0 Ⓜ	J	9-370- * - ◆ -TB600C0 Ⓜ	Y1
125	150	300	~	700	9-370- * - ◆ -TB700G0 Ⓜ	J	9-370- * - ◆ -TB700D0 Ⓜ	W	9-370- * - ◆ -TB700W0 Ⓜ	J	9-370- * - ◆ -TB700C0 Ⓜ	Y1
125	150	~	400	700	9-400-EI- * - ◆ -TB700G0	J	9-400-EI- * - ◆ -TB700D0	J	9-400-EI- * - ◆ -TB700W0	J	9-400-EI- * - ◆ -TB700C0	Y1
~	~	350	~	800	9-400-EI- * - ◆ -TB800G0	J	9-400-EI- * - ◆ -TB800D0	J	9-400-EI- * - ◆ -TB800W0	J	9-400-EI- * - ◆ -TB800C0	Y1
150	~	~	~	800	9-460-EI- * - ◆ -TB800G0	J	9-460-EI- * - ◆ -TB800D0	J	9-460-EI- * - ◆ -TB800W0	J	9-460-EI- * - ◆ -TB800C0	Y1
~	200	400	500	1000	9-460-EI- * - ◆ -TB1000G0	J	9-460-EI- * - ◆ -TB1000D0	J	9-460-EI- * - ◆ -TB1000W0	J	9-460-EI- * - ◆ -TB1000C0	Y1
200	~	~	600	1000	9-580-EI- * - ◆ -TB1000G0	R/F	9-580-EI- * - ◆ -TB1000D0	R/F	9-580-EI- * - ◆ -TB1000W0	R/F	9-580-EI- * - ◆ -TB1000C0	R/F
~	250	500	~	1200	9-580-EI- * - ◆ -TB1200G0	R/F	9-580-EI- * - ◆ -TB1200D0	R/F	9-580-EI- * - ◆ -TB1200W0	R/F	9-580-EI- * - ◆ -TB1200C0	R/F

Larger sizes available. Contact your Sprecher + Schuh representative.

NOTE: Catalog numbers and enclosure dimensions reflect contactors with AC coils. For DC coils, select Coil Code from the DC Coil Code table on page C104 and follow the instructions for modifying catalog numbers.

- ① Dimensional information starts on page C122.
- ② For Type 3R outdoor applications, replace "D" in catalog number with an "R". Dimensions may change. For example number CAUT7-30-*****-**◆**-TB50D0 becomes CAUT7-30-*****-**◆**-TB50R0.
- ③ Applicable to 600Y/347V only. Refer to page C63 for 600V Delta solution.
- ④ The short circuit and kAIC is relegated to the contactor's 10kA. Contact your Sprecher + Schuh representative for a higher kAIC.
- ⑤ CAUT9-116...CAUT9-370 starters are available with "EI" option for PLC interface. Change catalog number to include "EI". Example: CAUT9-116-*****-**◆**-TB175G0 becomes CAUT9-116-EI-*****-**◆**-TB175G0.

Ordering Instructions

Specify Catalog Number	
Replace (*) with Coil Code	See page C104
Replace (◆) with O/L Relay	See pages C105-C106
Factory Modifications available	See pages C107-C111

Series CAUT7 & CAUT9 with Thermal-Magnetic Circuit Breaker - 600V Delta

Maximum Horse-power Three Phase				MCCB Amps	Type 1 General Purpose	D I M	Type 12 [Type 3R ☉] Industrial Dusttight	D I M	Type 4 Watertight	D I M	Type 4X Watertight Corrosion Resistant Non-metallic	D I M
200V	230V	460V	575V		Catalog No.	①	Catalog No.	①	Catalog No.	①	Catalog No.	①
					CAUT		CAUT		CAUT		CAUT	
2	2	5	5	15	7-9-*-◆-TBH15G0	D3	7-9-*-◆-TBH15D0	Q	7-9-*-◆-TBH15W0	Q	7-9-*-◆-TBH15C0	V2
~	~	~	7.5	20	7-9-*-◆-TBH20G0	D3	7-9-*-◆-TBH20D0	Q	7-9-*-◆-TBH20W0	Q	7-9-*-◆-TBH20C0	V2
3	3	7.5	10	20	7-12-*-◆-TBH20G0	D3	7-12-*-◆-TBH20D0	Q	7-12-*-◆-TBH20W0	Q	7-12-*-◆-TBH20C0	V2
5	~	~	15	35	7-23-*-◆-TBH35G0	D3	7-23-*-◆-TBH35D0	Q	7-23-*-◆-TBH35W0	Q	7-23-*-◆-TBH35C0	V2
~	~	~	20	40	7-30-*-◆-TBH40G0	D3	7-30-*-◆-TBH40D0	Q	7-30-*-◆-TBH40W0	Q	7-30-*-◆-TBH40C0	V2
7.5	10	20	25	50	7-30-*-◆-TBH50G0	D3	7-30-*-◆-TBH50D0	Q	7-30-*-◆-TBH50W0	Q	7-30-*-◆-TBH50C0	V2
10	~	25	30	60	7-37-*-◆-TBH60G0	D3	7-37-*-◆-TBH60D0	Q	7-37-*-◆-TBH60W0	Q	7-37-*-◆-TBH60C0	V2
15	20	40	40	80	7-55-*-◆-TBH80G0	D3	7-55-*-◆-TBH80D0	Q	7-55-*-◆-TBH80W0	Q	7-55-*-◆-TBH80C0	V2
~	~	~	40	80	7-60-*-◆-TBH80G0	D3	7-60-*-◆-TBH80D0	Q	7-60-*-◆-TBH80W0	Q	7-60-*-◆-TBH80C0	W2
15	20	40	50	100	7-60-*-◆-TBH100G0	D3	7-60-*-◆-TBH100D0	Q	7-60-*-◆-TBH100W0	Q	7-60-*-◆-TBH100C0	W2
~	25	~	60	125	7-72-*-◆-TBH125G0	D3	7-72-*-◆-TBH125D0	Q	7-72-*-◆-TBH125W0	Q	7-72-*-◆-TBH125C0	W2
~	~	~	75 ☉	150	7-97-*-◆-TBH150G0	D3	7-97-*-◆-TBH150D0	Q	7-97-*-◆-TBH150W0	Q	7-97-*-◆-TBH150C0	W2
30	~	75	~	175	9-116-*-◆-TBH175G0 ☉	E2	9-116-*-◆-TBH175D0 ☉	R2	9-116-*-◆-TBH175W0 ☉	R2	9-116-*-◆-TBH175C0 ☉	X1
~	40	~	100 ☉	200	9-116-*-◆-TBH200G0 ☉	E2	9-116-*-◆-TBH200D0 ☉	R2	9-116-*-◆-TBH200W0 ☉	R2	9-116-*-◆-TBH200C0 ☉	X1
40	~	100	125 ☉	225	9-146-*-◆-TBH225G0 ☉	G	9-146-*-◆-TBH225D0 ☉	T	9-146-*-◆-TBH225W0 ☉	T	9-146-*-◆-TBH225C0 ☉	X1

Combination Starters

Ordering Instructions

Specify Catalog Number	
Replace (*) with Coil Code	See page C104
Replace (◆) with O/L Relay	See pages C105-C106
Factory Modifications available	See pages C107-C111

NOTE: Catalog numbers and enclosure dimensions reflect contactors with AC coils. For DC coils, select Coil Code from the DC Coil Code table on page C104 and follow the instructions for modifying catalog numbers.

- ① Dimensional information starts on page C122.
- ② For Type 3R outdoor applications, replace "D" in catalog number with an "R". Dimensions may change. For example number CAUT7-30-*-◆-TBH50D0 becomes CAUT7-30-*-◆-TBH50R0.
- ③ The short circuit and kAIC is relegated to the contactor's 10kA. Contact your Sprecher + Schuh representative for a higher kAIC.
- ④ CAUT9-116...CAUT9-370 starters are available with "EI" option for PLC interface. Change catalog number to include "-EI". Example: CAUT9-116-*-◆-TBH175G0 becomes CAUT9-116-EI-*-◆-TBH175G0.

Series CAT7 & CAT9 with Fusible Disconnect (J-Type) ①②

Maximum Horsepower Three Phase				Fuse Clip Amps	Type 1 General Purpose	DIM	Type 12 [Type 3R ②] Industrial Dusttight	DIM	Type 4 Watertight	DIM	Type 4X Watertight Corrosion Resistant Non-metallic	DIM
200V	230V	460V	575V		Catalog No.		① Catalog No.		① Catalog No.		① Catalog No.	
					CAT		CAT		CAT		CAT	
2	2	5	7.5	30	7-9-*◆-JF61G0	C	7-9-*◆-JF61D0	C2	7-9-*◆-JF61W0	Q	7-9-*◆-JF61C0	V1
3	3	7.5	10	30	7-12-*◆-JF61G0	C	7-12-*◆-JF61D0	C2	7-12-*◆-JF61W0	Q	7-12-*◆-JF61C0	V1
5	5	10	15	30	7-16-*◆-JF61G0	C	7-16-*◆-JF61D0	C2	7-16-*◆-JF61W0	Q	7-16-*◆-JF61C0	V1
5	~	~	15	30	7-23-*◆-JF61G0	C	7-23-*◆-JF61D0	C2	7-23-*◆-JF61W0	Q	7-23-*◆-JF61C0	V1
~	7.5	15	~	60	7-23-*◆-JF62G0	C	7-23-*◆-JF62D0	C2	7-23-*◆-JF62W0	Q	7-23-*◆-JF62C0	V1
7.5	10	20	25	60	7-30-*◆-JF62G0	C	7-30-*◆-JF62D0	C2	7-30-*◆-JF62W0	Q	7-30-*◆-JF62C0	V1
10	10	25	30	60	7-37-*◆-JF62G0	C	7-37-*◆-JF62D0	C2	7-37-*◆-JF62W0	Q	7-37-*◆-JF62C0	V1
10	~	30	30	60	7-43-*◆-JF62G0	C	7-43-*◆-JF62D0	C2	7-43-*◆-JF62W0	Q	7-43-*◆-JF62C0	V1
~	15	~	~	100	7-43-*◆-JF63G0	D3	7-43-*◆-JF63D0	Q	7-43-*◆-JF63W0	Q	7-43-*◆-JF63C0	W1
~	~	~	40	60	7-55-*◆-JF62G0	C	7-55-*◆-JF62D0	C2	7-55-*◆-JF62W0	Q	7-55-*◆-JF62C0	V1
15	20	40	~	100	7-55-*◆-JF63G0	D3	7-55-*◆-JF63D0	Q	7-55-*◆-JF63W0	Q	7-55-*◆-JF63C0	W1
~	~	~	40	60	7-60-*◆-JF62G0	D3	7-60-*◆-JF62D0	Q	7-60-*◆-JF62W0	Q	7-60-*◆-JF62C0	W2
15	20	40	50	100	7-60-*◆-JF63G0	D3	7-60-*◆-JF63D0	Q	7-60-*◆-JF63W0	Q	7-60-*◆-JF63C0	W2
20	25	50	60	100	7-72-*◆-JF63G0	D3	7-72-*◆-JF63D0	Q	7-72-*◆-JF63W0	Q	7-72-*◆-JF63C0	W2
~	~	~	60	100	7-85-*◆-JF63G0	D3	7-85-*◆-JF63D0	Q	7-85-*◆-JF63W0	Q	7-85-*◆-JF63C0	W2
25	30	60	~	200	7-85-*◆-JF64G0	G	7-85-*◆-JF64D0	T	7-85-*◆-JF64W0	T	7-85-*◆-JF64C0	X1
30	30	75	75	200	7-97-*◆-JF64G0	G	7-97-*◆-JF64D0	T	7-97-*◆-JF64W0	T	7-97-*◆-JF64C0	X1
30	40	75	100	200	9-116-*◆-JF64G0 ③	G	9-116-*◆-JF64D0 ③	T	9-116-*◆-JF64W0 ③	T	9-116-*◆-JF64C0 ③	A2
40	50	100	125	200	9-146-*◆-JF64G0 ③	G	9-146-*◆-JF64D0 ③	T	9-146-*◆-JF64W0 ③	T	9-146-*◆-JF64C0 ③	A2
50	60	125	150	400	9-190-*◆-JF65G0 ③	H	9-190-*◆-JF65D0 ③	H	9-190-*◆-JF65W0 ③	H	9-190-*◆-JF65C0 ③	Y1
60	75	150	200	400	9-205-*◆-JF65G0 ③	H	9-205-*◆-JF65D0 ③	H	9-205-*◆-JF65W0 ③	H	9-205-*◆-JF65C0 ③	Y1
75	100	200	250	400	9-265-*◆-JF65G0 ③	J	9-265-*◆-JF65D0 ③	J	9-265-*◆-JF65W0 ③	J	9-265-*◆-JF65C0 ③	Y1
100	125	250	300	600	9-305-*◆-JF66G0 ③	R/F	9-305-*◆-JF66D0 ③	R/F	9-305-*◆-JF66W0 ③	R/F	9-305-*◆-JF66C0 ③	R/F
125	150	300	350	600	9-370-*◆-JF66G0 ③	R/F	9-370-*◆-JF66D0 ③	R/F	9-370-*◆-JF66W0 ③	R/F	9-370-*◆-JF66C0 ③	R/F
125	150	~	400	600	9-400-EI-*◆-JF66G0	R/F	9-400-EI-*◆-JF66D0	R/F	9-400-EI-*◆-JF66W0	R/F	9-400-EI-*◆-JF66C0	R/F
~	~	350	~	800	9-400-EI-*◆-JF67G0	R/F	9-400-EI-*◆-JF67D0	R/F	9-400-EI-*◆-JF67W0	R/F	9-400-EI-*◆-JF67C0	R/F
150	200	400	500	800	9-460-EI-*◆-JF67G0	R/F	9-460-EI-*◆-JF67D0	R/F	9-460-EI-*◆-JF67W0	R/F	9-460-EI-*◆-JF67C0	R/F

Larger sizes available. Contact your Sprecher + Schuh representative.

NOTE: Catalog numbers and enclosure dimensions reflect contactors with AC coils. For DC coils, select Coil Code from the DC Coil Code table on page C104 and follow the instructions for modifying catalog numbers.

- ① Dimensional information starts on page C122.
- ② For Type 3R outdoor applications, replace "D" in catalog number with an "R". Dimensions may change. For example number CAT7-23-*◆-JF62D0 becomes CAT7-23-*◆-JF62R0.
- ③ Fusible combo starter uses the L11 Disconnect. Fuse clips accept "J" type fuses. Power fuses not supplied.
- ④ A Red and Yellow Handle may be selected instead of the standard Black handle. Change "JF" to "LF" in catalog number.
- ⑤ CAT9-116...CAT9-370 starters are available with "EI" option for PLC interface. Change catalog number to include "-EI". Example: CAT9-116-*◆-JF64G0 becomes CAT9-116-EI-*◆-JF64G0.

Ordering Instructions

Specify Catalog Number	
Replace (*) with Coil Code	See page C104
Replace (◆) with O/L Relay	See pages C105-C106
Factory Modifications available	See pages C107-C111

Series CAUT7 & CAUT9 with Fusible Disconnect (J-Type) ④④

Maximum Horsepower Three Phase				Fuse Clips Amps	Type 1 General Purpose	DIM	Type 12 [Type 3R ②] Industrial Dusttight	DIM	Type 4 Watertight	DIM	Type 4X Watertight Corrosion Resistant Non-metallic	DIM
200V	230V	460V	575V		Catalog No.		① Catalog No.		① Catalog No.		① Catalog No.	
					CAUT		CAUT		CAUT		CAUT	
2	2	5	7.5	30	7-9-*◆-JF61G0	D3	7-9-*◆-JF61D0	Q	7-9-*◆-JF61W0	Q	7-9-*◆-JF61C0	V1
3	3	7.5	10	30	7-12-*◆-JF61G0	D3	7-12-*◆-JF61D0	Q	7-12-*◆-JF61W0	Q	7-12-*◆-JF61C0	V1
5	5	10	15	30	7-16-*◆-JF61G0	D3	7-16-*◆-JF61D0	Q	7-16-*◆-JF61W0	Q	7-16-*◆-JF61C0	V1
5	~	~	15	30	7-23-*◆-JF61G0	D3	7-23-*◆-JF61D0	Q	7-23-*◆-JF61W0	Q	7-23-*◆-JF61C0	V1
	7.5	15	~	60	7-23-*◆-JF62G0	D3	7-23-*◆-JF62D0	Q	7-23-*◆-JF62W0	Q	7-23-*◆-JF62C0	V1
7.5	10	20	25	60	7-30-*◆-JF62G0	D3	7-30-*◆-JF62D0	Q	7-30-*◆-JF62W0	Q	7-30-*◆-JF62C0	V1
10	10	25	30	60	7-37-*◆-JF62G0	D3	7-37-*◆-JF62D0	Q	7-37-*◆-JF62W0	Q	7-37-*◆-JF62C0	V1
10	~	30	30	60	7-43-*◆-JF62G0	D3	7-43-*◆-JF62D0	Q	7-43-*◆-JF62W0	Q	7-43-*◆-JF62C0	V1
~	15	~	~	100	7-43-*◆-JF63G0	E	7-43-*◆-JF63D0	R	7-43-*◆-JF63W0	R	7-43-*◆-JF63C0	W1
~	~	~	40	60	7-55-*◆-JF62G0	D3	7-55-*◆-JF62D0	Q	7-55-*◆-JF62W0	Q	7-55-*◆-JF62C0	V1
15	20	40	~	100	7-55-*◆-JF63G0	E	7-55-*◆-JF63D0	R	7-55-*◆-JF63W0	R	7-55-*◆-JF63C0	W1
~	~	~	40	60	7-60-*◆-JF62G0	E	7-60-*◆-JF62D0	R	7-60-*◆-JF62W0	R	7-60-*◆-JF62C0	W2
15	20	40	50	100	7-60-*◆-JF63G0	E	7-60-*◆-JF63D0	R	7-60-*◆-JF63W0	R	7-60-*◆-JF63C0	W2
20	25	50	60	100	7-72-*◆-JF63G0	E	7-72-*◆-JF63D0	R	7-72-*◆-JF63W0	R	7-72-*◆-JF63C0	W2
~	~	~	60	100	7-85-*◆-JF63G0	E	7-85-*◆-JF63D0	R	7-85-*◆-JF63W0	R	7-85-*◆-JF63C0	W2
25	30	60	~	200	7-85-*◆-JF64G0	F	7-85-*◆-JF64D0	T	7-85-*◆-JF64W0	T	7-85-*◆-JF64C0	A2
30	30	75	75	200	7-97-*◆-JF64G0	F	7-97-*◆-JF64D0	T	7-97-*◆-JF64W0	T	7-97-*◆-JF64C0	A2
30	40	75	100	200	9-116-*◆-JF64G0 ⑤	H	9-116-*◆-JF64D0 ⑤	H	9-116-*◆-JF64W0 ⑤	H	9-116-*◆-JF64C0 ⑤	Y1
40	50	100	125	200	9-146-*◆-JF64G0 ⑤	H	9-146-*◆-JF64D0 ⑤	H	9-146-*◆-JF64W0 ⑤	H	9-146-*◆-JF64C0 ⑤	Y1
50	60	125	150	400	9-190-*◆-JF65G0 ⑤	J	9-190-*◆-JF65D0 ⑤	J	9-190-*◆-JF65W0 ⑤	J	9-190-*◆-JF65C0 ⑤	Z1
60	75	150	200	400	9-205-*◆-JF65G0 ⑤	J	9-205-*◆-JF65D0 ⑤	J	9-205-*◆-JF65W0 ⑤	J	9-205-*◆-JF65C0 ⑤	Z1
75	100	200	250	400	9-265-*◆-JF65G0 ⑤	J	9-265-*◆-JF65D0 ⑤	J	9-265-*◆-JF65W0 ⑤	J	9-265-*◆-JF65C0 ⑤	Z1
100	125	250	300	600	9-305-*◆-JF66G0 ⑤	R/F	9-305-*◆-JF66D0 ⑤	R/F	9-305-*◆-JF66W0 ⑤	R/F	9-305-*◆-JF66C0 ⑤	R/F
125	150	300	350	600	9-370-*◆-JF66G0 ⑤	R/F	9-370-*◆-JF66D0 ⑤	R/F	9-370-*◆-JF66W0 ⑤	R/F	9-370-*◆-JF66C0 ⑤	R/F
125	150	~	400	600	9-400-EI-*◆-JF66G0	R/F	9-400-EI-*◆-JF66D0	R/F	9-400-EI-*◆-JF66W0	R/F	9-400-EI-*◆-JF66C0	R/F
~	~	350	~	800	9-400-EI-*◆-JF67G0	R/F	9-400-EI-*◆-JF67D0	R/F	9-400-EI-*◆-JF67W0	R/F	9-400-EI-*◆-JF67C0	R/F
150	200	400	500	800	9-460-EI-*◆-JF67G0	R/F	9-460-EI-*◆-JF67D0	R/F	9-460-EI-*◆-JF67W0	R/F	9-460-EI-*◆-JF67C0	R/F

Larger sizes available. Contact your Sprecher + Schuh representative.

NOTE: Catalog numbers and enclosure dimensions reflect contactors with AC coils. For DC coils, select Coil Code from the DC Coil Code table on page C104 and follow the instructions for modifying catalog numbers.

- ① Dimensional information starts on page C122
- ② For Type 3R outdoor applications, replace "D" in catalog number with an "R". Dimensions may change. For example number CAUT7-23-*◆-JF62D0 becomes CAUT7-23-*◆-JF62R0.
- ③ Fusible combo starter used the L11 Disconnect. Fuse clips accept "J" type fuses. Power fuses not supplied.
- ④ A Red and Yellow Handle may be selected instead of the standard y and Black handle. Change "JF" to "LF" in catalog number.
- ⑤ CAUT9-116...CAUT9-370 starters are available with "EI" option for PLC interface. Change catalog number to include "-EI". Example: CAUT9-116-*◆-JF64G0 becomes CAUT9-116-EI-*◆-JF64G0.

Ordering Instructions

Specify Catalog Number	
Replace (*) with Coil Code	See page C104
Replace (◆) with O/L Relay	See pages C105-C106
Factory Modifications available	See pages C107-C111

Series CAT7 & CAT9 with Non-Fusible Disconnect

Maximum Horsepower Three Phase				Disc Size/ Amps	Type 1 General Purpose	DIM	Type 12 [Type 3R] Industrial Dusttight	DIM	Type 4 Watertight	DIM	Type 4X Watertight Corrosion Resistant Non-metallic	DIM
200V	230V	460V	575V		Catalog No.		① Catalog No.		① Catalog No.		① Catalog No.	
					CAT		CAT		CAT		CAT	
2	2	5	7.5	30	7-9-*◆-JU61G0	C	7-9-*◆-JU61D0	C2	7-9-*◆-JU61W0	Q	7-9-*◆-JU61C0	V1
3	3	7.5	10	30	7-12-*◆-JU61G0	C	7-12-*◆-JU61D0	C2	7-12-*◆-JU61W0	Q	7-12-*◆-JU61C0	V1
5	5	10	15	30	7-16-*◆-JU61G0	C	7-16-*◆-JU61D0	C2	7-16-*◆-JU61W0	Q	7-16-*◆-JU61C0	V1
5	7.5	15	15	30	7-23-*◆-JU61G0	C	7-23-*◆-JU61D0	C2	7-23-*◆-JU61W0	Q	7-23-*◆-JU61C0	V1
7.5	~	~	20	30	7-30-*◆-JU61G0	C	7-30-*◆-JU61D0	C2	7-30-*◆-JU61W0	Q	7-30-*◆-JU61C0	V1
~	10	20	25	60	7-30-*◆-JU62G0	C	7-30-*◆-JU62D0	C2	7-30-*◆-JU62W0	Q	7-30-*◆-JU62C0	V1
10	10	25	30	60	7-37-*◆-JU62G0	C	7-37-*◆-JU62D0	C2	7-37-*◆-JU62W0	Q	7-37-*◆-JU62C0	V1
10	15	30	30	60	7-43-*◆-JU62G0	C	7-43-*◆-JU62D0	C2	7-43-*◆-JU62W0	Q	7-43-*◆-JU62C0	V1
15	~	~	40	60	7-55-*◆-JU62G0	C	7-55-*◆-JU62D0	C2	7-55-*◆-JU62W0	Q	7-55-*◆-JU62C0	V1
~	20	40	~	100	7-55-*◆-JU63G0	D3	7-55-*◆-JU63D0	Q	7-55-*◆-JU63W0	Q	7-55-*◆-JU63C0	W2
15	~	~	~	60	7-60-*◆-JU62G0	D3	7-60-*◆-JU62D0	Q	7-60-*◆-JU62W0	Q	7-60-*◆-JU62C0	W2
~	20	40	50	100	7-60-*◆-JU63G0	D3	7-60-*◆-JU63D0	Q	7-60-*◆-JU63W0	Q	7-60-*◆-JU63C0	W2
20	25	50	60	100	7-72-*◆-JU63G0	D3	7-72-*◆-JU63D0	Q	7-72-*◆-JU63W0	Q	7-72-*◆-JU63C0	W2
25	30	60	60	100	7-85-*◆-JU63G0	D3	7-85-*◆-JU63D0	Q	7-85-*◆-JU63W0	Q	7-85-*◆-JU63C0	W2
~	30	~	75	100	7-97-*◆-JU63G0	D3	7-97-*◆-JU63D0	Q	7-97-*◆-JU63W0	Q	7-97-*◆-JU63C0	W2
30	~	75	~	200	7-97-*◆-JU64G0	G	7-97-*◆-JU64D0	T	7-97-*◆-JU64W0	T	7-97-*◆-JU64C0	X1
30	40	75	100	200	9-116-*◆-JU64G0	G	9-116-*◆-JU64D0	T	9-116-*◆-JU64W0	T	9-116-*◆-JU64C0	A2
40	50	100	125	200	9-146-*◆-JU64G0	G	9-146-*◆-JU64D0	T	9-146-*◆-JU64W0	T	9-146-*◆-JU64C0	A2
50	60	125	150	200	9-190-*◆-JU64G0	G	9-190-*◆-JU64D0	T	9-190-*◆-JU64W0	T	9-190-*◆-JU64C0	A2
60	75	150	200	400	9-205-*◆-JU65G0	H	9-205-*◆-JU65D0	H	9-205-*◆-JU65W0	H	9-205-*◆-JU65C0	Y1
75	100	200	250	400	9-265-*◆-JU65G0	J	9-265-*◆-JU65D0	J	9-265-*◆-JU65W0	J	9-265-*◆-JU65C0	Y1
100	125	250	300	400	9-305-*◆-JU65G0	J	9-305-*◆-JU65D0	J	9-305-*◆-JU65W0	J	9-305-*◆-JU65C0	Y1

Larger sizes available. Contact your Sprecher + Schuh representative.

NOTE: Catalog numbers and enclosure dimensions reflect contactors with AC coils. For DC coils, select Coil Code from the DC Coil Code table on page C104 and follow the instructions for modifying catalog numbers.

- ① Dimensional information starts on page C122.
- ② For Type 3R outdoor applications, replace "D" in catalog number with an "R". Dimensions may change. For example number CAT7-23-*◆-JU61D0 becomes CAT7-23-*◆-JU61R0.
- ③ Non-fusible combo-starter uses the L11 Non-Fusible Disconnect.
- ④ A Red and Yellow Handle may be selected instead of the standard Black handle. Change "JU" to "LU" in catalog number.
- ⑤ CAT9-116...CAT9-370 starters are available with "EI" option for PLC interface. Change catalog number to include "-EI". Example: CAT9-116-*◆-JU64G0 becomes CAT9-116-EI-*◆-JU64G0.

Ordering Instructions

Specify Catalog Number	
Replace (*) with Coil Code	See page C104
Replace (◆) with O/L Relay	See pages C105-C106
Factory Modifications available	See pages C107-C111

Series CAUT7 & CAUT9 with Non-Fusible Disconnect ④

Maximum Horsepower Three Phase					Disc Size/ Amps	Type 1 General Purpose	D I M	Type 12 [Type 3R ②] Industrial Dusttight	D I M	Type 4 Watertight	D I M	Type 4X Watertight Corrosion Resistant Non-metallic	D I M
200V	230V	460V	575V	Catalog No.		① Catalog No.		① Catalog No.		① Catalog No.			
					CAUT		CAUT		CAUT		CAUT		
2	2	5	7.5	30	7-9-*-◆-JU61G0	D3	7-9-*-◆-JU61D0	Q	7-9-*-◆-JU61W0	Q	7-9-*-◆-JU61C0	W1	
3	3	7.5	10	30	7-12-*-◆-JU61G0	D3	7-12-*-◆-JU61D0	Q	7-12-*-◆-JU61W0	Q	7-12-*-◆-JU61C0	W1	
5	5	10	15	30	7-16-*-◆-JU61G0	D3	7-16-*-◆-JU61D0	Q	7-16-*-◆-JU61W0	Q	7-16-*-◆-JU61C0	W1	
5	7.5	15	15	30	7-23-*-◆-JU61G0	D3	7-23-*-◆-JU61D0	Q	7-23-*-◆-JU61W0	Q	7-23-*-◆-JU61C0	W1	
7.5	~	~	20	30	7-30-*-◆-JU61G0	D3	7-30-*-◆-JU61D0	Q	7-30-*-◆-JU61W0	Q	7-30-*-◆-JU61C0	W1	
~	10	20	25	60	7-30-*-◆-JU62G0	D3	7-30-*-◆-JU62D0	Q	7-30-*-◆-JU62W0	Q	7-30-*-◆-JU62C0	W1	
10	10	25	30	60	7-37-*-◆-JU62G0	D3	7-37-*-◆-JU62D0	Q	7-37-*-◆-JU62W0	Q	7-37-*-◆-JU62C0	W1	
10	15	30	30	60	7-43-*-◆-JU62G0	D3	7-43-*-◆-JU62D0	Q	7-43-*-◆-JU62W0	Q	7-43-*-◆-JU62C0	W1	
15	~	~	40	60	7-55-*-◆-JU62G0	D3	7-55-*-◆-JU62D0	Q	7-55-*-◆-JU62W0	Q	7-55-*-◆-JU62C0	W1	
~	20	40	~	100	7-55-*-◆-JU63G0	E	7-55-*-◆-JU63D0	R	7-55-*-◆-JU63W0	R	7-55-*-◆-JU63C0	W2	
15	~	~	~	60	7-60-*-◆-JU62G0	E	7-60-*-◆-JU62D0	Q	7-60-*-◆-JU62W0	Q	7-60-*-◆-JU62C0	W2	
~	20	40	50	100	7-60-*-◆-JU63G0	E	7-60-*-◆-JU63D0	R	7-60-*-◆-JU63W0	R	7-60-*-◆-JU63C0	W2	
20	25	50	60	100	7-72-*-◆-JU63G0	E	7-72-*-◆-JU63D0	R	7-72-*-◆-JU63W0	R	7-72-*-◆-JU63C0	W2	
25	30	60	60	100	7-85-*-◆-JU63G0	E	7-85-*-◆-JU63D0	R	7-85-*-◆-JU63W0	R	7-85-*-◆-JU63C0	W2	
~	30	~	75	100	7-97-*-◆-JU63G0	E	7-97-*-◆-JU63D0	R	7-97-*-◆-JU63W0	R	7-97-*-◆-JU63C0	W2	
30	~	75	~	200	7-97-*-◆-JU64G0	F	7-97-*-◆-JU64D0	T	7-97-*-◆-JU64W0	T	7-97-*-◆-JU64C0	A2	
30	40	75	100	200	9-116-*-◆-JU64G0 ⑤	H	9-116-*-◆-JU64D0 ⑤	H	9-116-*-◆-JU64W0 ⑤	H	9-116-*-◆-JU64C0 ⑤	Y1	
40	50	100	125	200	9-146-*-◆-JU64G0 ⑤	H	9-146-*-◆-JU64D0 ⑤	H	9-146-*-◆-JU64W0 ⑤	H	9-146-*-◆-JU64C0 ⑤	Y1	
50	60	125	150	200	9-190-*-◆-JU64G0 ⑤	J	9-190-*-◆-JU64D0 ⑤	J	9-190-*-◆-JU64W0 ⑤	J	9-190-*-◆-JU64C0 ⑤	Z1	
60	75	150	200	400	9-205-*-◆-JU65G0 ⑤	J	9-205-*-◆-JU65D0 ⑤	J	9-205-*-◆-JU65W0 ⑤	J	9-205-*-◆-JU65C0 ⑤	Z1	
75	100	200	250	400	9-265-*-◆-JU65G0 ⑤	J	9-265-*-◆-JU65D0 ⑤	J	9-265-*-◆-JU65W0 ⑤	J	9-265-*-◆-JU65C0 ⑤	Z1	
100	125	250	300	400	9-305-*-◆-JU65G0 ⑤	J	9-305-*-◆-JU65D0 ⑤	J	9-305-*-◆-JU65W0 ⑤	J	9-305-*-◆-JU65C0 ⑤	Z1	

Larger sizes available. Contact your Sprecher + Schuh representative.

C
Combination Starters

Ordering Instructions

Specify Catalog Number	
Replace (*) with Coil Code	See page C104
Replace (◆) with O/L Relay	See pages C105-C106
Factory Modifications available	See pages C107-C111

NOTE: Catalog numbers and enclosure dimensions reflect contactors with AC coils. For DC coils, select Coil Code from the DC Coil Code table on page C104 and follow the instructions for modifying catalog numbers.

- ① Dimensional information starts on page C122.
- ② For Type 3R outdoor applications, replace "D" in catalog number with an "R". Dimensions may change. For example number CAUT7-23-*-◆-JU61D0 becomes CAUT7-23-*-◆-JU61R0.
- ③ Non-fusible combo-starter uses the L11 Non-Fusible Disconnect.
- ④ A Red and Yellow Handle may be selected instead of the standard Black handle. Change "JU" to "LU" in catalog number.
- ⑤ CAUT9-116...CAUT9-370 starters are available with "EI" option for PLC interface. Change catalog number to include "-EI". Example: CAUT9-116-*-◆-JU64G0 becomes CAUT9-116-EI-*-◆-JU64G0.

NEMA Sized Combination Starters - Through the Door Operated

NEMA Combination Starters

Smart and cost effective... for any application

Sprecher + Schuh's through-the-door operated combination starters represent an economical alternative to the classic flange-operated combo solution. It is designed to meet rigid UL/NEC withstand specifications. Sprecher + Schuh has been building custom control panels with this design for years. Experience the durability of this product!

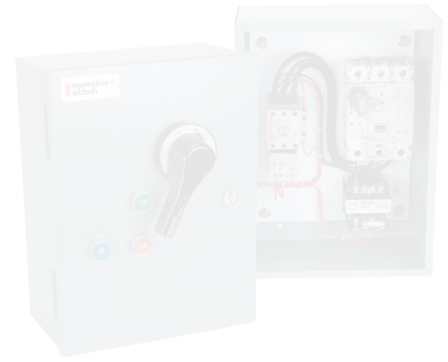

Starting with the best

At the heart of all Sprecher + Schuh NEMA sized combination starters is the CATN7 line of motor starters. Each starter proudly displays the NEMA size (00, 0, 1, 2, or 3) and HP at applied voltage. This line of starters is designed to meet rigid consultant specifications for NEMA starters.

Thermal Magnetic Molded Case Circuit Breaker (MCCB)

The through-the-door operated combo MCCB is available to meet UL short circuit withstand specifications. An MCCB prevents single phasing by simultaneously opening all three phases when a fault occurs in any one phase. An MCCB can be reset after the fault has been cleared.

Top line protection...

NEMA labeled combination starters are equipped with Sprecher + Schuh premium CEP7 solid state thermal relay standard. Unlike traditional overload relays which directly sense motor current through heat elements, the CEP7 solid state relay directly measures motor current through integrated current sensors and on board electronics. The electronics provide numerous advantages over electromechanical relays. Alternatively, the CT7N Thermal Overload Relay may also be selected.

Disconnect Switches

The through-the-door operated combo is available with the L11 switch. A mechanical door interlock system prevents the door from being opened when the disconnect is closed, and conversely, prevents the disconnect from being closed when the door is open. Both functions can be defeated for test and maintenance purposes. Other safety features include padlock provisions and a high visibility operating handle.

Choice of Disconnect

- Choices for disconnect include:
- Thermal Magnetic Molded Case Circuit Breaker (MCCB)
- L11 Fusible or Non-Fusible Disconnect switch

The L11 Switch disconnects have a quick make/quick break, non-teasing action. The L11 fusible switch is suitable for interrupting up to 100,000 amperes when class "J" fuses are used. All L11 disconnect switches conform to UL 98 standards.

Choice of Enclosures

- Available enclosures include;
- Type 1 General Purpose
- Type 3R Raintight
- Type 12 Dusttight
- Type 4 Watertight
- Type 4X Corrosion Resistant



CAN7 NEMA labeled contactor (AC)

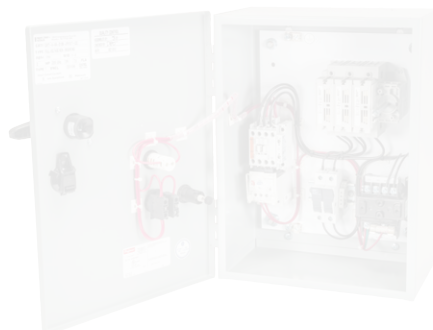
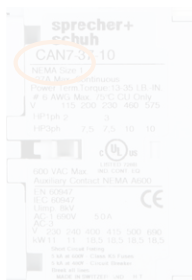

See new NEMA Starters Section starting at page 101.1

Series CATN7 with Thermal-Magnetic Circuit Breaker

NEMA Size	Maximum Horse-power Three Phase				MCCB Amps	Type 1 General Purpose	D I M	Type 12 [Type 3R Ⓣ] Industrial Dusttight	D I M	Type 4 Watertight	D I M	Type 4X Watertight Corrosion Resistant Non-metallic	D I M
	200V	230V	460V	575V		Catalog No.	Ⓣ Catalog No.	Ⓣ Catalog No.	Ⓣ Catalog No.				
						CATN		CATN		CATN		CATN	
00	1-1/2	1-1/2	2	2 Ⓣ	15	7-12-*◆-TB15G0	C2	7-12-*◆-TB15D0	C3	7-12-*◆-TB15W0	C2	7-12-*◆-TB15C0	V2
0	2	2	5	5 Ⓣ	15	7-16-*◆-TB15G0	C2	7-16-*◆-TB15D0	C3	7-16-*◆-TB15W0	C2	7-16-*◆-TB15C0	V2
	3	3	~	~	20	7-16-*◆-TB20G0	C2	7-16-*◆-TB20D0	C3	7-16-*◆-TB20W0	C2	7-16-*◆-TB20C0	V2
1	~	~	7-1/2	10 Ⓣ	20	7-37-*◆-TB20G0	C2	7-37-*◆-TB20D0	C3	7-37-*◆-TB20W0	C2	7-37-*◆-TB20C0	V2
	~	5	10	~	30	7-37-*◆-TB30G0	C2	7-37-*◆-TB30D0	C3	7-37-*◆-TB30W0	C2	7-37-*◆-TB30C0	V2
	5	~	~	~	35	7-37-*◆-TB35G0	C2	7-37-*◆-TB35D0	C3	7-37-*◆-TB35W0	C2	7-37-*◆-TB35C0	V2
	~	7-1/2	~	~	40	7-37-*◆-TB40G0	C2	7-37-*◆-TB40D0	C3	7-37-*◆-TB40W0	C2	7-37-*◆-TB40C0	V2
	7-1/2	~	~	~	50	7-37-*◆-TB50G0	C2	7-37-*◆-TB50D0	C3	7-37-*◆-TB50W0	C2	7-37-*◆-TB50C0	V2
2	~	~	~	15 Ⓣ	35	7-43-*◆-TB35G0	C2	7-43-*◆-TB35D0	C3	7-43-*◆-TB35W0	C2	7-43-*◆-TB35C0	V2
	~	~	15	20 Ⓣ	40	7-43-*◆-TB40G0	C2	7-43-*◆-TB40D0	C3	7-43-*◆-TB40W0	C2	7-43-*◆-TB40C0	V2
	~	10	20	25 Ⓣ	50	7-43-*◆-TB50G0	C2	7-43-*◆-TB50D0	C3	7-43-*◆-TB50W0	C2	7-43-*◆-TB50C0	V2
	10	~	25	~	60	7-43-*◆-TB60G0	C2	7-43-*◆-TB60D0	C3	7-43-*◆-TB60W0	C2	7-43-*◆-TB60C0	V2
	~	15	~	~	80	7-43-*◆-TB80G0	C2	7-43-*◆-TB80D0	C3	7-43-*◆-TB80W0	C2	7-43-*◆-TB80C0	V2
3	~	~	~	30 Ⓣ	60	7-85-*◆-TB60G0	D3	7-85-*◆-TB60D0	Q	7-85-*◆-TB60W0	Q	7-85-*◆-TB60C0	W2
	~	~	30	40 Ⓣ	80	7-85-*◆-TB80G0	D3	7-85-*◆-TB80D0	Q	7-85-*◆-TB80W0	Q	7-85-*◆-TB80C0	W2
	15	20	40	50 Ⓣ	100	7-85-*◆-TB100G0	D3	7-85-*◆-TB100D0	Q	7-85-*◆-TB100W0	Q	7-85-*◆-TB100C0	W2
	25	30	50	~	125	7-85-*◆-TB125G0	D3	7-85-*◆-TB125D0	Q	7-85-*◆-TB125W0	Q	7-85-*◆-TB125C0	W2

This page has moved. See new NEMA Starters Section starting at page 101.1

NEMA Combination Starters

NOTE: Catalog numbers and enclosure dimensions reflect contactors with AC coils. For DC coils, select Coil Code from the DC Coil Code table on page C104 and follow the instructions for modifying catalog numbers.

Ordering Instructions

Specify Catalog Number	
Replace (*) with Coil Code	See page C104
Replace (◆) with O/L Relay	See pages C105-C106
Factory Modifications available	See pages C107-C111

- Ⓣ Dimensional information starts on page C122.
- Ⓣ For Type 3R outdoor applications, replace "D" in catalog number with an "R". Dimensions may change. For example number CATN7-37-*◆-TB40D0 becomes CATN7-37-*◆-TB40R0.
- Ⓣ Applicable to 600Y/347V only. Refer to page C70 for 600V Delta solution.

Series CATN7 with Thermal-Magnetic Circuit Breaker - 600V Delta

NEMA Size	Maximum Horsepower Three Phase				MCCB Amps	Type 1 General Purpose	D I M	Type 12 [Type 3R Ⓣ] Industrial Dusttight	D I M	Type 4 Watertight	D I M	Type 4X Watertight Corrosion Resistant Non-metallic	D I M
	200V	230V	460V	575V		Catalog No.	Ⓣ Catalog No.	Ⓣ Catalog No.	Ⓣ Catalog No.	Ⓣ Catalog No.			
						CATN		CATN		CATN		CATN	
00	1-1/2	1-1/2	2	2	15	7-12-*-◆-TBH15G0	C2	7-12-*-◆-TBH15D0	C3	7-12-*-◆-TBH15W0	C2	7-12-*-◆-TBH15C0	V2
0	2	3	5	5	15	7-16-*-◆-TBH15G0	C2	7-16-*-◆-TBH15D0	C3	7-16-*-◆-TBH15W0	C2	7-16-*-◆-TBH15C0	V2
1	~	~	7-1/2	10	20	7-37-*-◆-TBH20G0	C2	7-37-*-◆-TBH20D0	C3	7-37-*-◆-TBH20W0	C2	7-37-*-◆-TBH20C0	V2
2	~	~	~	15	35	7-43-*-◆-TBH35G0	C2	7-43-*-◆-TBH35D0	C3	7-43-*-◆-TBH35W0	C2	7-43-*-◆-TBH35C0	V2
	~	~	15	20	40	7-43-*-◆-TBH40G0	C2	7-43-*-◆-TBH40D0	C3	7-43-*-◆-TBH40W0	C2	7-43-*-◆-TBH40C0	V2
	~	~	20	25	50	7-43-*-◆-TBH50G0	C2	7-43-*-◆-TBH50D0	C3	7-43-*-◆-TBH50W0	C2	7-43-*-◆-TBH50C0	V2
3	~	~	~	30	60	7-85-*-◆-TBH60G0	D3	7-85-*-◆-TBH60D0	Q	7-85-*-◆-TBH60W0	Q	7-85-*-◆-TBH60C0	W2
	~	~	30	40	80	7-85-*-◆-TBH80G0	D3	7-85-*-◆-TBH80D0	Q	7-85-*-◆-TBH80W0	Q	7-85-*-◆-TBH80C0	W2
	15	20	40	50	100	7-85-*-◆-TBH100G0	D3	7-85-*-◆-TBH100D0	Q	7-85-*-◆-TBH100W0	Q	7-85-*-◆-TBH100C0	W2

See new NEMA Starters Section starting at page 101.1
This page has moved.

NOTE: Catalog numbers and enclosure dimensions reflect contactors with AC coils. For DC coils, select Coil Code from the DC Coil Code table on page C104 and follow the instructions for modifying catalog numbers.

Ordering Instructions

Specify Catalog Number	
Replace (*) with Coil Code	See page C104
Replace (◆) with O/L Relay	See pages C105-C106
Factory Modifications available	See pages C107-C111

- Ⓣ Dimensional information starts on page C122.
- Ⓣ For Type 3R outdoor applications, replace "D" in catalog number with an "R". Dimensions may change. For example number CATN7-37-*-◆-TBH40D0 becomes CATN7-37-*-◆-TBH40R0.

NEMA Combination Starters

Series CATN7 208V AC with Thermal-Magnetic Circuit Breaker

NEMA Size	Max HP 3-Phase Ⓢ	Auxiliary Contacts per Contactor Ⓣ		MCCB Amps	Type 1 Metallic General Purpose	DIM	Type 3R Metallic Outdoor Raintight	DIM
		NO	NC		Catalog No.		Ⓢ Catalog No.	
00	0.25	2	1	15	CATN7-12-XA-D1BB-TB15G17-L11	C2	CATN7-12-XA-D1BB-TB15R17-L11	0
	0.5	2	1	15	CATN7-12-XA-D1CB-TB15G17-L11	C2	CATN7-12-XA-D1CB-TB15R17-L11	0
	0.75	2	1	15	CATN7-12-XA-D1CB-TB15G17-L11	C2	CATN7-12-XA-D1CB-TB15R17-L11	0
	1	2	1	15	CATN7-12-XA-D1CB-TB15G17-L11	C2	CATN7-12-XA-D1CB-TB15R17-L11	0
	1.5	2	1	15	CATN7-12-XA-D1DB-TB15G17-L11	C2	CATN7-12-XA-D1DB-TB15R17-L11	0
0	2	2	1	15	CATN7-16-XA-D1DB-TB15G17-L11	C2	CATN7-16-XA-D1DB-TB15R17-L11	0
	3	2	1	20	CATN7-16-XA-D1DB-TB20G17-L11	C2	CATN7-16-XA-D1DB-TB20R17-L11	0
1	5	2	1	35	CATN7-37-XA-D1ED-TB35G17-L11	C2	CATN7-37-XA-D1ED-TB35R17-L11	0
	7.5	2	1	50	CATN7-37-XA-D1ED-TB50G17-L11	C2	CATN7-37-XA-D1ED-TB50R17-L11	0
2	10	2	1	60	CATN7-43-XA-D1FD-TB60G17-L11	C2	CATN7-43-XA-D1FD-TB60R17-L11	0
3	15	2	1	100	CATN7-85-XA-EGE-TB100G17-L11	D3	CATN7-85-XA-EGE-TB100R17-L11	0
	20	2	1	125	CATN7-85-XA-EGE-TB125G17-L11	D3	CATN7-85-XA-EGE-TB125R17-L11	0
	25	2	1	125	CATN7-85-XA-EGE-TB125G17-L11	D3	CATN7-85-XA-EGE-TB125R17-L11	0

- Full Voltage Non-Reversing (FVNR) Features include:**
- NEMA-sized CAN7 contactor
 - Three-Phase CEP7 Electronic Overload Relay
 - Control Circuit Transformer
 - Hand-Off-Auto (H-O-A) selector switch
 - Red Run pilot light
 - 2-NO and 1-NC auxiliaries for customer use
 - Class CC Fuse holder as fused primary of CCT
 - Reset pushbutton
 - UL489 600V class thermal-magnetic molded case circuit breaker

NEMA Combination Starters

This page has moved.
See new NEMA Starters Section starting at page 101.1

Series CATN7 230V AC with Thermal-Magnetic Circuit Breaker

NEMA Size	Max HP 3-Phase Ⓢ	Auxiliary Contacts per Contactor Ⓣ		MCCB Amps	Type 1 Metallic General Purpose	DIM	Type 3R Metallic Outdoor Raintight	DIM
		NO	NC		Catalog No.		Ⓢ Catalog No.	
00	0.25	2	1	15	CATN7-12-XB-D1BB-TB15G17-L11	C2	CATN7-12-XB-D1BB-TB15R17-L11	0
	0.5	2	1	15	CATN7-12-XB-D1CB-TB15G17-L11	C2	CATN7-12-XB-D1CB-TB15R17-L11	0
	0.75	2	1	15	CATN7-12-XB-D1CB-TB15G17-L11	C2	CATN7-12-XB-D1CB-TB15R17-L11	0
	1	2	1	15	CATN7-12-XB-D1CB-TB15G17-L11	C2	CATN7-12-XB-D1CB-TB15R17-L11	0
	1.5	2	1	15	CATN7-12-XB-D1CB-TB15G17-L11	C2	CATN7-12-XB-D1CB-TB15R17-L11	0
0	2	2	1	15	CATN7-16-XB-D1DB-TB15G17-L11	C2	CATN7-16-XB-D1DB-TB15R17-L11	0
	3	2	1	15	CATN7-16-XB-D1DB-TB15G17-L11	C2	CATN7-16-XB-D1DB-TB15R17-L11	0
1	5	2	1	30	CATN7-37-XB-D1ED-TB30G17-L11	C2	CATN7-37-XB-D1ED-TB30R17-L11	0
	7.5	2	1	40	CATN7-37-XB-D1ED-TB40G17-L11	C2	CATN7-37-XB-D1ED-TB40R17-L11	0
2	10	2	1	60	CATN7-43-XB-D1FD-TB60G17-L11	C2	CATN7-43-XB-D1FD-TB60R17-L11	0
	15	2	1	80	CATN7-43-XB-D1FD-TB80G17-L11	C2	CATN7-43-XB-D1FD-TB80R17-L11	0
3	20	2	1	100	CATN7-85-XB-EGE-TB100G17-L11	D3	CATN7-85-XB-EGE-TB100R17-L11	0
	25	2	1	125	CATN7-85-XB-EGE-TB125G17-L11	D3	CATN7-85-XB-EGE-TB125R17-L11	0
	30	2	1	150	CATN7-85-XB-EGE-TB150G17-L11	D3	CATN7-85-XB-EGE-TB150R17-L11	0

- Ⓢ HP and NEMA size selection shown for 208V ratings only. Contact your Sprecher + Schuh representative for other voltage applications.
- Ⓣ Contactors are equipped with number and type of auxiliaries indicated. See page C108 to order additional or different auxiliary contacts.

- Ⓢ Dimensional information starts on page C122.
- Ⓢ HP and NEMA size selection shown for 230V ratings only. Contact your Sprecher + Schuh representative for other voltage applications.

Series CATN7 460V AC with Thermal-Magnetic Circuit Breaker

NEMA Size	Max HP 3-Phase ①	Auxiliary Contacts per Contactor ②		MCCB Amps	Type 1 Metallic General Purpose	DIM	Type 3R Metallic Outdoor Raintight	DIM
		NO	NC		Catalog No.		③ Catalog No.	
00	0.25	2	1	15	CATN7-12-XC-D1BB-TB15G17-L11	C2	CATN7-12-XC-D1BB-TB15R17-L11	0
	0.5	2	1	15	CATN7-12-XC-D1CB-TB15G17-L11	C2	CATN7-12-XC-D1CB-TB15R17-L11	0
	0.75	2	1	15	CATN7-12-XC-D1CB-TB15G17-L11	C2	CATN7-12-XC-D1CB-TB15R17-L11	0
	1	2	1	15	CATN7-12-XC-D1CB-TB15G17-L11	C2	CATN7-12-XC-D1CB-TB15R17-L11	0
	1.5	2	1	15	CATN7-12-XC-D1CB-TB15G17-L11	C2	CATN7-12-XC-D1CB-TB15R17-L11	0
	2	2	1	15	CATN7-12-XC-D1CB-TB15G17-L11	C2	CATN7-12-XC-D1CB-TB15R17-L11	0
0	3	2	1	15	CATN7-16-XC-D1DB-TB15G17-L11	C2	CATN7-16-XC-D1DB-TB15R17-L11	0
	5	2	1	15	CATN7-16-XC-D1DB-TB15G17-L11	C2	CATN7-16-XC-D1DB-TB15R17-L11	0
1	7.5	2	1	20	CATN7-37-XC-D1ED-TB20G17-L11	C2	CATN7-37-XC-D1ED-TB20R17-L11	0
	10	2	1	30	CATN7-37-XC-D1ED-TB30G17-L11	C2	CATN7-37-XC-D1ED-TB30R17-L11	0
2	15	2	1	40	CATN7-43-XC-D1FD-TB40G17-L11	C2	CATN7-43-XC-D1FD-TB40R17-L11	0
	20	2	1	50	CATN7-43-XC-D1FD-TB50G17-L11	C2	CATN7-43-XC-D1FD-TB50R17-L11	0
	25	2	1	60	CATN7-43-XC-D1FD-TB60G17-L11	C2	CATN7-43-XC-D1FD-TB60R17-L11	0
3	30	2	1	80	CATN7-85-XC-EGE-TB80G17-L11	D3	CATN7-85-XC-EGE-TB80R17-L11	0
	40	2	1	100	CATN7-85-XC-EGE-TB100G17-L11	D3	CATN7-85-XC-EGE-TB100R17-L11	0
	50	2	1	125	CATN7-85-XC-EGE-TB125G17-L11	D3	CATN7-85-XC-EGE-TB125R17-L11	0

- Full Voltage Non-Reversing (FVNR) Features include:**
- NEMA-sized CAN7 contactor
 - Three-Phase CEP7 Electronic Overload Relay
 - Control Circuit Transformer
 - Hand-Off-Auto (H-O-A) selector switch
 - Red Run pilot light
 - 2-NO and 1-NC auxiliaries for customer use
 - Class CC Fuse holder as fused primary of CCT
 - Reset pushbutton
 - UL489 600V class thermal-magnetic molded case circuit breaker

See new NEMA Starters Section starting at page 101.1
This page has moved.

NEMA Combination Starters

① HP and NEMA size selection shown for 460V ratings only. Contact your Sprecher + Schuh representative for other voltage applications.

② Contactors are equipped with number and type of auxiliaries indicated. See page C108 to order additional or different auxiliary contacts.
③ Dimensional information starts on page C122.

Series CATN7 575V AC with Thermal-Magnetic Circuit Breaker

NEMA Size	Max HP 3-Phase ①	Auxiliary Contacts per Contactor ②		MCCB Amps	Type 1 Metallic General Purpose (except TBH)	DIM	Type 3R Metallic Outdoor Raintight	DIM
		NO	NC		Catalog No.		Catalog No.	
00	0.25	2	1	15	CATN7-12-XD-D1BB-TBH15G17-L11	C2	CATN7-12-XD-D1BB-TBH15R17-L11	0
	0.5	2	1	15	CATN7-12-XD-D1CB-TBH15G17-L11	C2	CATN7-12-XD-D1CB-TBH15R17-L11	0
	0.75	2	1	15	CATN7-12-XD-D1CB-TBH15G17-L11	C2	CATN7-12-XD-D1CB-TBH15R17-L11	0
	1	2	1	15	CATN7-12-XD-D1CB-TBH15G17-L11	C2	CATN7-12-XD-D1CB-TBH15R17-L11	0
	2	2	1	15	CATN7-12-XD-D1CB-TBH15G17-L11	C2	CATN7-12-XD-D1CB-TBH15R17-L11	0
0	3	2	1	15	CATN7-16-XD-D1DB-TBH15G17-L11	C2	CATN7-16-XD-D1DB-TBH15R17-L11	0
	5	2	1	15	CATN7-16-XD-D1DB-TBH15G17-L11	C2	CATN7-16-XD-D1DB-TBH15R17-L11	0
1	7.5 ③	2	1	20	CATN7-37-XD-D1ED-TB20G17-L11	C2	CATN7-37-XD-D1ED-TB20R17-L11	0
	10 ③	2	1	20	CATN7-37-XD-D1FD-TB20G17-L11	C2	CATN7-37-XD-D1ED-TB20R17-L11	0
	7.5	2	1	20	CATN7-37-XD-D1ED-TBH20G17-L11	C2	CATN7-37-XD-D1ED-TBH20R17-L11	0
	10	2	1	20	CATN7-37-XD-D1FD-TBH20G17-L11	C2	CATN7-37-XD-D1FD-TBH20R17-L11	0
2	15 ③	2	1	35	CATN7-43-XD-D1FD-TB35G17-L11	C2	CATN7-43-XD-D1FD-TB35R17-L11	0
	20 ③	2	1	40	CATN7-43-XD-D1FD-TB40G17-L11	C2	CATN7-43-XD-D1FD-TB40R17-L11	0
	25 ③	2	1	50	CATN7-43-XD-D1FD-TB50G17-L11	C2	CATN7-43-XD-D1FD-TB50R17-L11	0
	15	2	1	35	CATN7-43-XD-D1FD-TBH35G17-L11	C2	CATN7-43-XD-D1FD-TBH35R17-L11	0
	20	2	1	40	CATN7-43-XD-D1FD-TBH40G17-L11	C2	CATN7-43-XD-D1FD-TBH40R17-L11	0
	25	2	1	50	CATN7-43-XD-D1FD-TBH50G17-L11	C2	CATN7-43-XD-D1FD-TBH50R17-L11	0
3	30 ③	2	1	60	CATN7-85-XD-EGE-TB60G17-L11	D3	CATN7-85-XD-EGE-TB60R17-L11	0
	40 ③	2	1	80	CATN7-85-XD-EGE-TB80G17-L11	D3	CATN7-85-XD-EGE-TB80R17-L11	0
	50 ③	2	1	100	CATN7-85-XD-EGE-TB100G17-L11	D3	CATN7-85-XD-EGE-TB100R17-L11	0
	30	2	1	60	CATN7-85-XD-EGE-TBH60G17-L11	D3	CATN7-85-XD-EGE-TBH60R17-L11	0
	40	2	1	80	CATN7-85-XD-EGE-TBH80G17-L11	D3	CATN7-85-XD-EGE-TBH80R17-L11	0
	50	2	1	100	CATN7-85-XD-EGE-TBH100G17-L11	D3	CATN7-85-XD-EGE-TBH100R17-L11	0
	50	2	1	100	CATN7-85-XD-EGE-TBH100G17-L11	D3	CATN7-85-XD-EGE-TBH100R17-L11	0

This page has moved.
See new NEMA Starters Section starting at page 101.1

Full Voltage Non-Reversing (FVNR) Features include:

- NEMA-sized CAN7 contactor
- Three-Phase CEP7 Electronic Overload Relay
- Control Circuit Transformer
- Hand-Off-Auto (H-O-A) selector switch
- Red Run pilot light
- 2-NO and 1-NC auxiliaries for customer use
- Class CC Fuse holder as fused primary of CCT
- Reset pushbutton
- UL489 600V class thermal-magnetic molded case circuit breaker

NEMA Combination Starters

① HP and NEMA size selection shown for 575V ratings only. Contact your Sprecher + Schuh representative for other voltage applications.

② Contactors are equipped with number and type of auxiliaries indicated. See page C108 to order additional or different auxiliary contacts.

③ Dimensional information starts on page C122.

④ Applicable to 600Y/347V only.

Series CATN7 with Fusible Disconnect (J-Type) ⑥⑥

NEMA Size	Maximum Horsepower Three Phase				Fuse Clip Amps	Type 1 General Purpose	D I M	Type 12 [Type 3R ⑥]	D I M	Type 4 Watertight	D I M	Type 4X Watertight Corrosion Resistant Non-metallic	D I M
	200V	230V	460V	575V		Catalog No.	①	Catalog No.	①	Catalog No.	①	Catalog No.	①
						CATN		CATN		CATN		CATN	
00	1-1/2	1-1/2	2	2	30	7-12-*◆-JF61G0	C	7-12-*◆-JF61D0	C2	7-12-*◆-JF61W0	Q	7-12-*◆-JF61C0	V1
0	3	3	5	5	30	7-16-*◆-JF61G0	C	7-16-*◆-JF61D0	C2	7-16-*◆-JF61W0	Q	7-16-*◆-JF61C0	V1
1	5	5	10	10	30	7-37-*◆-JF61G0	C	7-37-*◆-JF61D0	C2	7-37-*◆-JF61W0	Q	7-37-*◆-JF61C0	V1
	7-1/2	7-1/2	~	~	60	7-37-*◆-JF62G0	C	7-37-*◆-JF62D0	C2	7-37-*◆-JF62W0	Q	7-37-*◆-JF62C0	V1
2	~	~	~	15	30	7-43-*◆-JF61G0	C	7-43-*◆-JF61D0	C2	7-43-*◆-JF61W0	Q	7-43-*◆-JF61C0	V1
	10	10	25	25	60	7-43-*◆-JF62G0	C	7-43-*◆-JF62D0	C2	7-43-*◆-JF62W0	Q	7-43-*◆-JF62C0	V1
	~	15	~	~	100	7-43-*◆-JF63G0	D3	7-43-*◆-JF63D0	Q	7-43-*◆-JF63W0	Q	7-43-*◆-JF63C0	W1
3	~	~	30	40	60	7-85-*◆-JF62G0	D3	7-85-*◆-JF62D0	Q	7-85-*◆-JF62W0	Q	7-85-*◆-JF62C0	W2
	20	25	50	50	100	7-85-*◆-JF63G0	D3	7-85-*◆-JF63D0	Q	7-85-*◆-JF63W0	Q	7-85-*◆-JF63C0	W2
	25	30	~	~	200	7-85-*◆-JF64G0	G	7-85-*◆-JF64D0	T	7-85-*◆-JF64W0	T	7-85-*◆-JF64C0	X1

This page has moved.
 See new NEMA Starters Section starting at page 101.1

NOTE: Catalog numbers and enclosure dimensions reflect contactors with AC coils. For DC coils, select Coil Code from the DC Coil Code table on page C104 and follow the instructions for modifying catalog numbers.

Ordering Instructions

Specify Catalog Number	
Replace (*) with Coil Code	See page C104
Replace (◆) with O/L Relay	See pages C105-C106
Factory Modifications available	See pages C107-C111

- ⑥ Dimensional information starts on page C122.
- ⑥ For Type 3R outdoor applications, replace "D" in catalog number with an "R". Dimensions may change. For example number CATN7-16-*◆-JF61D0 becomes CATN7-16-*◆-JF61R0.
- ⑥ Fusible combo starter uses the L11 Disconnect. Fuse clips accept "J" type fuses. Power fuses not supplied.
- ⑥ A Red and Yellow Handle may be selected instead of the standard Black handle. Change "JF" to "LF" in catalog number.

Series CATN7 208V AC with Fusible Disconnect (J-Type) ☉☉

NEMA Size	Max HP 3-Phase ☉	Auxiliary Contacts per Contactor ☉		Fuse Clip Amps	Type 1 Metallic General Purpose	DIM	Type 3R Metallic Outdoor Raintight	DIM
		NO	NC		Catalog No.		Catalog No.	
00	0.25	2	1	30	CATN7-12-XA-D1BB-JF61G17-L11	C	CATN7-12-XA-D1BB-JF61R17-L11	0
	0.5	2	1	30	CATN7-12-XA-D1CB-JF61G17-L11	C	CATN7-12-XA-D1CB-JF61R17-L11	0
	0.75	2	1	30	CATN7-12-XA-D1CB-JF61G17-L11	C	CATN7-12-XA-D1CB-JF61R17-L11	0
	1	2	1	30	CATN7-12-XA-D1CB-JF61G17-L11	C	CATN7-12-XA-D1CB-JF61R17-L11	0
	1.5	2	1	30	CATN7-12-XA-D1DB-JF61G17-L11	C	CATN7-12-XA-D1DB-JF61R17-L11	0
0	2	2	1	30	CATN7-16-XA-D1DB-JF61G17-L11	C	CATN7-16-XA-D1DB-JF61R17-L11	0
	3	2	1	30	CATN7-16-XA-D1DB-JF61G17-L11	C	CATN7-16-XA-D1DB-JF61R17-L11	0
1	5	2	1	30	CATN7-37-XA-D1ED-JF61G17-L11	C	CATN7-37-XA-D1ED-JF61R17-L11	0
	7.5	2	1	60	CATN7-37-XA-D1ED-JF62G17-L11	C	CATN7-37-XA-D1ED-JF62R17-L11	0
2	10	2	1	60	CATN7-43-XA-D1FD-JF62G17-L11	C	CATN7-43-XA-D1FD-JF62R17-L11	0
3	15	2	1	100	CATN7-85-XA-EGE-JF63G17-L11	D3	CATN7-85-XA-EGE-JF63R17-L11	0
	20	2	1	100	CATN7-85-XA-EGE-JF63G17-L11	D3	CATN7-85-XA-EGE-JF63R17-L11	0
	25	2	1	200	CATN7-85-XA-EGE-JF64G17-L11	G	CATN7-85-XA-EGE-JF64R17-L11	T

Full Voltage Non-Reversing (FVNR) Features include:

- NEMA-sized CAN7 contactor
- Three-Phase CEP7 Electronic Overload Relay
- Control Circuit Transformer
- Hand-Off-Auto (H-O-A) selector switch
- Red Run pilot light
- 2-NO and 1-NC auxiliaries for customer use
- Class CC Fuse holder as fused primary of CCT
- UL98 fusible L11 disconnect
- Reset pushbutton

NEMA Combination Starters

Series CATN7 230V AC with Fusible Disconnect (J-Type) ☉☉

NEMA Size	Max HP 3-Phase ☉	Auxiliary Contacts per Contactor ☉		Fuse Clip Amps	Type 1 Metallic General Purpose	DIM	Type 3R Metallic Outdoor Raintight	DIM
		NO	NC		Catalog No.		Catalog No.	
00	0.25	2	1	30	CATN7-12-XB-D1BB-JF61G17-L11	C	CATN7-12-XB-D1BB-JF61R17-L11	0
	0.5	2	1	30	CATN7-12-XB-D1CB-JF61G17-L11	C	CATN7-12-XB-D1CB-JF61R17-L11	0
	0.75	2	1	30	CATN7-12-XB-D1CB-JF61G17-L11	C	CATN7-12-XB-D1CB-JF61R17-L11	0
	1	2	1	30	CATN7-12-XB-D1CB-JF61G17-L11	C	CATN7-12-XB-D1CB-JF61R17-L11	0
	1.5	2	1	30	CATN7-12-XB-D1DB-JF61G17-L11	C	CATN7-12-XB-D1DB-JF61R17-L11	0
0	2	2	1	30	CATN7-16-XB-D1DB-JF61G17-L11	C	CATN7-16-XB-D1DB-JF61R17-L11	0
	3	2	1	30	CATN7-16-XB-D1DB-JF61G17-L11	C	CATN7-16-XB-D1DB-JF61R17-L11	0
1	5	2	1	30	CATN7-37-XB-D1ED-JF61G17-L11	C	CATN7-37-XB-D1ED-JF61R17-L11	0
	7.5	2	1	60	CATN7-37-XB-D1ED-JF62G17-L11	C	CATN7-37-XB-D1ED-JF62R17-L11	0
2	10	2	1	60	CATN7-43-XB-D1FD-JF62G17-L11	C	CATN7-43-XB-D1FD-JF62R17-L11	0
	15	2	1	100	CATN7-43-XB-D1FD-JF63G17-L11	C	CATN7-43-XB-D1FD-JF63R17-L11	0
3	20	2	1	100	CATN7-85-XB-EGE-JF63G17-L11	D3	CATN7-85-XB-EGE-JF63R17-L11	0
	25	2	1	100	CATN7-85-XB-EGE-JF63G17-L11	D3	CATN7-85-XB-EGE-JF63R17-L11	0
	30	2	1	200	CATN7-85-XB-EGE-JF64G17-L11	G	CATN7-85-XB-EGE-JF64R17-L11	T

Full Voltage Non-Reversing (FVNR) Features include:

- NEMA-sized CAN7 contactor
- Three-Phase CEP7 Electronic Overload Relay
- Control Circuit Transformer
- Hand-Off-Auto (H-O-A) selector switch
- Red Run pilot light
- 2-NO and 1-NC auxiliaries for customer use
- Class CC Fuse holder as fused primary of CCT
- UL98 fusible L11 disconnect
- Reset pushbutton

This page has moved.
See new NEMA Starters Section starting at page 101.1

- ☉ HP and NEMA size selection shown for 208V ratings only. Contact your Sprecher + Schuh representative for other voltage application.
- ☉ Contactors are equipped with number and type of auxiliaries indicated. See page C108 to order additional or different auxiliary contacts.
- ☉ Fusible combo starter uses the L11 Disconnect. Fuse clips accept "J" type fuses. Power fuses not supplied.
- ☉ A Red and Yellow Handle may be selected instead of the standard Black handle. Change "JF" to "LF" in catalog number.
- ☉ HP and NEMA size selection shown for 230V ratings only. Contact your Sprecher + Schuh representative for other voltage application.
- ☉ Dimensional information starts on page C122.

Series CATN7 460V AC with Fusible Disconnect (J-Type) ⑥⑦

NEMA Size	Max HP 3-Phase ④	Auxiliary Contacts per Contactor ②		Fuse Clip Amps	Type 1 Metallic General Purpose	DIM	Type 3R Metallic Outdoor Raintight	DIM
		NO	NC		Catalog No.		⑤ Catalog No.	
00	0.25	2	1	30	CATN7-12-XC-D18B-JF61G17-L11	C	CATN7-12-XC-D18B-JF61R17-L11	0
	0.5	2	1	30	CATN7-12-XC-D1CB-JF61G17-L11	C	CATN7-12-XC-D1CB-JF61R17-L11	0
	0.75	2	1	30	CATN7-12-XC-D1CB-JF61G17-L11	C	CATN7-12-XC-D1CB-JF61R17-L11	0
	1	2	1	30	CATN7-12-XC-D1CB-JF61G17-L11	C	CATN7-12-XC-D1CB-JF61R17-L11	0
	1.5	2	1	30	CATN7-12-XC-D1CB-JF61G17-L11	C	CATN7-12-XC-D1CB-JF61R17-L11	0
	2	2	1	30	CATN7-12-XC-D1CB-JF61G17-L11	C	CATN7-12-XC-D1CB-JF61R17-L11	0
0	3	2	1	30	CATN7-16-XC-D1DB-JF61G17-L11	C	CATN7-16-XC-D1DB-JF61R17-L11	0
	5	2	1	30	CATN7-16-XC-D1DB-JF61G17-L11	C	CATN7-16-XC-D1DB-JF61R17-L11	0
1	7.5	2	1	30	CATN7-37-XC-D1ED-JF61G17-L11	C	CATN7-37-XC-D1ED-JF61R17-L11	0
	10	2	1	30	CATN7-37-XC-D1ED-JF61G17-L11	C	CATN7-37-XC-D1ED-JF61R17-L11	0
2	15	2	1	60	CATN7-43-XC-D1FD-JF62G17-L11	C	CATN7-43-XC-D1FD-JF62R17-L11	0
	20	2	1	60	CATN7-43-XC-D1FD-JF62G17-L11	C	CATN7-43-XC-D1FD-JF62R17-L11	0
	25	2	1	60	CATN7-43-XC-D1FD-JF62G17-L11	C	CATN7-43-XC-D1FD-JF62R17-L11	0
3	30	2	1	60	CATN7-85-XC-EGE-JF62G17-L11	D3	CATN7-85-XC-EGE-JF62R17-L11	0
	40	2	1	100	CATN7-85-XC-EGE-JF63G17-L11	D3	CATN7-85-XC-EGE-JF63R17-L11	0
	50	2	1	100	CATN7-85-XC-EGE-JF63G17-L11	D3	CATN7-85-XC-EGE-JF63R17-L11	0

Full Voltage Non-Reversing (FVNR) Features include:

- NEMA-sized CAN7 contactor
- Three-Phase CEP7 Electronic Overload Relay
- Control Circuit Transformer
- Hand-Off-Auto (H-O-A) selector switch
- Red Run pilot light
- 2-NO and 1-NC auxiliaries for customer use
- Class CC Fuse holder as fused primary of CCT
- UL98 fusible L11 disconnect
- Reset pushbutton

This page has moved.
See new NEMA Starters Section starting at page 101.1

Series CATN7 575V AC with Fusible Disconnect (J-Type) ⑥⑦

NEMA Size	Max HP 3-Phase ④	Auxiliary Contacts per Contactor ②		Fuse Clip Amps	Type 1 Metallic General Purpose	DIM	Type 3R Metallic Outdoor Raintight	DIM
		NO	NC		Catalog No.		⑤ Catalog No.	
00	0.25	2	1	30	CATN7-12-XD-D18B-JF61G17-L11	C	CATN7-12-XD-D18B-JF61R17-L11	0
	0.5	2	1	30	CATN7-12-XD-D1CB-JF61G17-L11	C	CATN7-12-XD-D1CB-JF61R17-L11	0
	0.75	2	1	30	CATN7-12-XD-D1CB-JF61G17-L11	C	CATN7-12-XD-D1CB-JF61R17-L11	0
	1	2	1	30	CATN7-12-XD-D1CB-JF61G17-L11	C	CATN7-12-XD-D1CB-JF61R17-L11	0
	1.5	2	1	30	CATN7-12-XD-D1CB-JF61G17-L11	C	CATN7-12-XD-D1CB-JF61R17-L11	0
	2	2	1	30	CATN7-12-XD-D1CB-JF61G17-L11	C	CATN7-12-XD-D1CB-JF61R17-L11	0
0	3	2	1	30	CATN7-16-XD-D1DB-JF61G17-L11	C	CATN7-16-XD-D1DB-JF61R17-L11	0
	5	2	1	30	CATN7-16-XD-D1DB-JF61G17-L11	C	CATN7-16-XD-D1DB-JF61R17-L11	0
1	7.5	2	1	30	CATN7-37-XD-D1ED-JF61G17-L11	C	CATN7-37-XD-D1ED-JF61R17-L11	0
	10	2	1	30	CATN7-37-XD-D1ED-JF61G17-L11	C	CATN7-37-XD-D1ED-JF61R17-L11	0
2	15	2	1	60	CATN7-43-XD-D1FD-JF61G17-L11	C	CATN7-43-XD-D1FD-JF61R17-L11	0
	20	2	1	60	CATN7-43-XD-D1FD-JF62G17-L11	C	CATN7-43-XD-D1FD-JF62R17-L11	0
	25	2	1	60	CATN7-43-XD-D1FD-JF62G17-L11	C	CATN7-43-XD-D1FD-JF62R17-L11	0
3	30	2	1	60	CATN7-85-XD-EGE-JF62G17-L11	D3	CATN7-85-XD-EGE-JF62R17-L11	0
	40	2	1	60	CATN7-85-XD-EGE-JF62G17-L11	D3	CATN7-85-XD-EGE-JF62R17-L11	0
	50	2	1	100	CATN7-85-XD-EGE-JF63G17-L11	D3	CATN7-85-XD-EGE-JF63R17-L11	0

Full Voltage Non-Reversing (FVNR) Features include:

- NEMA-sized CAN7 contactor
- Three-Phase CEP7 Electronic Overload Relay
- Control Circuit Transformer
- Hand-Off-Auto (H-O-A) selector switch
- Red Run pilot light
- 2-NO and 1-NC auxiliaries for customer use
- Class CC Fuse holder as fused primary of CCT
- UL98 fusible L11 disconnect
- Reset pushbutton

- ① HP and NEMA size selection shown for 460V ratings only. Contact your Sprecher + Schuh representative for other voltage application.
- ② Contactors are equipped with number and type of auxiliaries indicated. See page C108 to order additional or different auxiliary contacts.
- ③ Fusible combo starter uses the L11 Disconnect. Fuse clips accept "J" type fuses. Power fuses not supplied.

- ④ A Red and Yellow Handle may be selected instead of the standard Black handle. Change "JF" to "LF" in catalog number.
- ⑤ HP and NEMA size selection shown for 575V ratings only. Contact your Sprecher + Schuh representative for other voltage application.
- ⑥ Dimensional information starts on page C122.

Series CATN7 with Non-Fusible Disconnect

NEMA Size	Maximum Horsepower Three Phase				Disc Size/Amps	Type 1 General Purpose	Type 12 [Type 3R] Industrial Dusttight	Type 4 Watertight	Type 4X Watertight Corrosion Resistant Non-metallic	
	200V	230V	460V	575V		Catalog No.	Ⓢ Catalog No.	Ⓢ Catalog No.	Ⓢ Catalog No.	Ⓢ
						CATN	CATN	CATN	CATN	
00	1-1/2	1-1/2	2	2	30	7-12-*◆-JU61G0	C 7-12-*◆-JU61D0	C2 7-12-*◆-JU61W0	Q 7-12-*◆-JU61C0	V1
0	3	3	5	5	30	7-16-*◆-JU61G0	C 7-16-*◆-JU61D0	C2 7-16-*◆-JU61W0	Q 7-16-*◆-JU61C0	V1
1	5	7-1/2	10	10	30	7-37-*◆-JU61G0	C 7-37-*◆-JU61D0	C2 7-37-*◆-JU61W0	Q 7-37-*◆-JU61C0	V1
	7-1/2	~	~	~	60	7-37-*◆-JU62G0	C 7-37-*◆-JU62D0	C2 7-37-*◆-JU62W0	Q 7-37-*◆-JU62C0	V1
2	~	~	15	15	30	7-43-*◆-JU61G0	C 7-43-*◆-JU61D0	C2 7-43-*◆-JU61W0	Q 7-43-*◆-JU61C0	V1
	10	15	25	25	60	7-43-*◆-JU62G0	C 7-43-*◆-JU62D0	C2 7-43-*◆-JU62W0	Q 7-43-*◆-JU62C0	V1
3	15	~	30	40	60	7-85-*◆-JU62G0	D3 7-85-*◆-JU62D0	Q 7-85-*◆-JU62W0	Q 7-85-*◆-JU62C0	W2
	25	30	50	50	100	7-85-*◆-JU63G0	D3 7-85-*◆-JU63D0	Q 7-85-*◆-JU63W0	Q 7-85-*◆-JU63C0	W2

NEMA Combination Starters

This page has moved.
 See new NEMA Starters Section starting at page 101.1

NOTE: Catalog numbers and enclosure dimensions reflect contactors with AC coils. For DC coils, select Coil Code from the DC Coil Code table on page C104 and follow the instructions for modifying catalog numbers.

Ordering Instructions

Specify Catalog Number	
Replace (*) with Coil Code	See page C104
Replace ◆ with O/L Relay	See pages C105-C106
Factory Modifications available	See pages C107-C111

- ① Dimensional information starts on page C122.
- ② For Type 3R outdoor applications, replace "D" in catalog number with an "R". Dimensions may change. For example number CATN7-16-*◆-JU61D0 becomes CATN7-16-*◆-JU61R0.
- ③ Non-fusible combo-starter uses the L11 Non-Fusible Disconnect.
- ④ A Red and Yellow Handle may be selected instead of the standard Black handle. Change "JU" to "LU" in catalog number.

Series CATN7 @208V AC with Non-Fusible Disconnect

NEMA Size	Max HP 3-Phase	Auxiliary Contacts per Contactor		Disc Size/ Amps	Type 1 Metallic General Purpose	DIM	Type 3R Metallic Outdoor Raintight	DIM
		NO	NC		Catalog No.		Catalog No.	
00	0.25	2	1	30	CATN7-12-XA-D18B-JU61G17-L11	C	CATN7-12-XA-D18B-JU61R17-L11	0
	0.5	2	1	30	CATN7-12-XA-D1CB-JU61G17-L11	C	CATN7-12-XA-D1CB-JU61R17-L11	0
	0.75	2	1	30	CATN7-12-XA-D1CB-JU61G17-L11	C	CATN7-12-XA-D1CB-JU61R17-L11	0
	1	2	1	30	CATN7-12-XA-D1CB-JU61G17-L11	C	CATN7-12-XA-D1CB-JU61R17-L11	0
	1.5	2	1	30	CATN7-12-XA-D1DB-JU61G17-L11	C	CATN7-12-XA-D1DB-JU61R17-L11	0
0	2	2	1	30	CATN7-16-XA-D1DB-JU61G17-L11	C	CATN7-16-XA-D1DB-JU61R17-L11	0
	3	2	1	30	CATN7-16-XA-D1DB-JU61G17-L11	C	CATN7-16-XA-D1DB-JU61R17-L11	0
1	5	2	1	30	CATN7-37-XA-D1ED-JU61G17-L11	C	CATN7-37-XA-D1ED-JU61R17-L11	0
	7.5	2	1	30	CATN7-37-XA-D1ED-JU61G17-L11	C	CATN7-37-XA-D1ED-JU61R17-L11	0
2	10	2	1	60	CATN7-43-XA-D1FD-JU62G17-L11	C	CATN7-43-XA-D1FD-JU62R17-L11	0
	15	2	1	60	CATN7-85-XA-EGE-JU62G17-L11	D3	CATN7-85-XA-EGE-JU62R17-L11	0
3	20	2	1	100	CATN7-85-XA-EGE-JU63G17-L11	D3	CATN7-85-XA-EGE-JU63R17-L11	0
	25	2	1	100	CATN7-85-XA-EGE-JU63G17-L11	D3	CATN7-85-XA-EGE-JU63R17-L11	0

Full Voltage Non-Reversing (FVNR) Features include:

- NEMA-sized CAN7 contactor
- Three-Phase CEP7 Electronic Overload Relay
- Control Circuit Transformer
- Hand-Off-Auto (H-O-A) selector switch
- Red Run pilot light
- 2-NO and 1-NC auxiliaries for customer use
- Class CC Fuse holder as fused primary of CCT
- UL98 non-fusible L11 disconnect switch
- Reset pushbutton

This page has moved.
See new NEMA Starters Section starting at page 101.1

Series CATN7 @230V AC with Non-Fusible Disconnect

NEMA Size	Max HP 3-Phase	Auxiliary Contacts per Contactor		Disc Size/ Amps	Type 1 Metallic General Purpose	DIM	Type 3R Metallic Outdoor Raintight	DIM
		NO	NC		Catalog No.		Catalog No.	
00	0.25	2	1	30	CATN7-12-XB-D18B-JU61G17-L11	C	CATN7-12-XB-D18B-JU61R17-L11	0
	0.5	2	1	30	CATN7-12-XB-D1CB-JU61G17-L11	C	CATN7-12-XB-D1CB-JU61R17-L11	0
	0.75	2	1	30	CATN7-12-XB-D1CB-JU61G17-L11	C	CATN7-12-XB-D1CB-JU61R17-L11	0
	1	2	1	30	CATN7-12-XB-D1CB-JU61G17-L11	C	CATN7-12-XB-D1CB-JU61R17-L11	0
	1.5	2	1	30	CATN7-12-XB-D1CB-JU61G17-L11	C	CATN7-12-XB-D1CB-JU61R17-L11	0
0	2	2	1	30	CATN7-16-XB-D1DB-JU61G17-L11	C	CATN7-16-XB-D1DB-JU61R17-L11	0
	3	2	1	30	CATN7-16-XB-D1DB-JU61G17-L11	C	CATN7-16-XB-D1DB-JU61R17-L11	0
1	5	2	1	30	CATN7-37-XB-D1ED-JU61G17-L11	C	CATN7-37-XB-D1ED-JU61R17-L11	0
	7.5	2	1	30	CATN7-37-XB-D1ED-JU61G17-L11	C	CATN7-37-XB-D1ED-JU61R17-L11	0
2	10	2	1	60	CATN7-43-XB-D1FD-JU62G17-L11	C	CATN7-43-XB-D1FD-JU62R17-L11	0
	15	2	1	60	CATN7-43-XB-D1FD-JU62G17-L11	C	CATN7-43-XB-D1FD-JU62R17-L11	0
3	20	2	1	100	CATN7-85-XB-EGE-JU63G17-L11	D3	CATN7-85-XB-EGE-JU63R17-L11	0
	25	2	1	100	CATN7-85-XB-EGE-JU63G17-L11	D3	CATN7-85-XB-EGE-JU63R17-L11	0
	30	2	1	100	CATN7-85-XB-EGE-JU63G17-L11	D3	CATN7-85-XB-EGE-JU63R17-L11	0

Full Voltage Non-Reversing (FVNR) Features include:

- NEMA-sized CAN7 contactor
- Three-Phase CEP7 Electronic Overload Relay
- Control Circuit Transformer
- Hand-Off-Auto (H-O-A) selector switch
- Red Run pilot light
- 2-NO and 1-NC auxiliaries for customer use
- Class CC Fuse holder as fused primary of CCT
- UL98 non-fusible L11 disconnect switch
- Reset pushbutton

- ① HP and NEMA size selection shown for 208V ratings only. Contact your Sprecher + Schuh representative for other voltage application.
- ② Contactors are equipped with number and type of auxiliaries indicated. See page C108 to order additional or different auxiliary contacts.
- ③ Fusible combo starter uses the L11 Disconnect. Fuse clips accept "J" type fuses. Power fuses not supplied.
- ④ A Red and Yellow Handle may be selected instead of the standard Black handle. Change "JF" to "LF" in catalog number.
- ⑤ HP and NEMA size selection shown for 230V ratings only. Contact your Sprecher + Schuh representative for other voltage application.
- ⑥ Dimensional information starts on page C122.

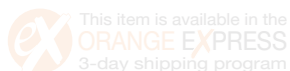

Series CATN7 @460V AC with Non-Fusible Disconnect

NEMA Size	Max HP 3-Phase	Auxiliary Contacts per Contactor		Disc Size/ Amps	Type 1 Metallic General Purpose	DIM	Type 3R Metallic Outdoor Raintight	DIM
		NO	NC		Catalog No.		Catalog No.	
00	0.25	2	1	30	CATN7-12-XC-D1BB-JU61G17-L11	C	CATN7-12-XC-D1BB-JU61R17-L11	0
	0.5	2	1	30	CATN7-12-XC-D1CB-JU61G17-L11	C	CATN7-12-XC-D1CB-JU61R17-L11	0
	0.75	2	1	30	CATN7-12-XC-D1CB-JU61G17-L11	C	CATN7-12-XC-D1CB-JU61R17-L11	0
	1	2	1	30	CATN7-12-XC-D1CB-JU61G17-L11	C	CATN7-12-XC-D1CB-JU61R17-L11	0
	1.5	2	1	30	CATN7-12-XC-D1CB-JU61G17-L11	C	CATN7-12-XC-D1CB-JU61R17-L11	0
	2	2	1	30	CATN7-12-XC-D1CB-JU61G17-L11	C	CATN7-12-XC-D1CB-JU61R17-L11	0
0	3	2	1	30	CATN7-16-XC-D1DB-JU61G17-L11	C	CATN7-16-XC-D1DB-JU61R17-L11	0
	5	2	1	30	CATN7-16-XC-D1DB-JU61G17-L11	C	CATN7-16-XC-D1DB-JU61R17-L11	0
1	7.5	2	1	30	CATN7-37-XC-D1ED-JU61G17-L11	C	CATN7-37-XC-D1ED-JU61R17-L11	0
	10	2	1	30	CATN7-37-XC-D1ED-JU61G17-L11	C	CATN7-37-XC-D1ED-JU61R17-L11	0
2	15	2	1	30	CATN7-43-XC-D1FD-JU61G17-L11	C	CATN7-43-XC-D1FD-JU61R17-L11	0
	20	2	1	60	CATN7-43-XC-D1FD-JU62G17-L11	C	CATN7-43-XC-D1FD-JU62R17-L11	0
	25	2	1	60	CATN7-43-XC-D1FD-JU62G17-L11	C	CATN7-43-XC-D1FD-JU62R17-L11	0
	30	2	1	60	CATN7-85-XC-EGE-JU62G17-L11	D3	CATN7-85-XC-EGE-JU62R17-L11	0
3	40	2	1	100	CATN7-85-XC-EGE-JU63G17-L11	D3	CATN7-85-XC-EGE-JU63R17-L11	0
	50	2	1	100	CATN7-85-XC-EGE-JU63G17-L11	D3	CATN7-85-XC-EGE-JU63R17-L11	0

Full Voltage Non-Reversing (FVNR) Features include:

- NEMA-sized CAN7 contactor
- Three-Phase CEP7 Electronic Overload Relay
- Control Circuit Transformer
- Hand-Off-Auto (H-O-A) selector switch
- Red Run pilot light
- 2-NO and 1-NC auxiliaries for customer use
- Class CC Fuse holder as fused primary of CCT
- UL98 non-fusible L11 disconnect switch
- Reset pushbutton

NEMA Combination Starters

This page has moved.
See new NEMA Starters Section starting at page 101.1

Series CATN7 @575V AC with Non-Fusible Disconnect

NEMA Size	Max HP 3-Phase	Auxiliary Contacts per Contactor		Disc Size/ Amps	Type 1 Metallic General Purpose	DIM	Type 3R Metallic Outdoor Raintight	DIM
		NO	NC		Catalog No.		Catalog No.	
00	0.25	2	1	30	CATN7-12-XD-D1BB-JU61G17-L11	C	CATN7-12-XD-D1BB-JU61R17-L11	0
	0.5	2	1	30	CATN7-12-XD-D1CB-JU61G17-L11	C	CATN7-12-XD-D1CB-JU61R17-L11	0
	0.75	2	1	30	CATN7-12-XD-D1CB-JU61G17-L11	C	CATN7-12-XD-D1CB-JU61R17-L11	0
	1	2	1	30	CATN7-12-XD-D1CB-JU61G17-L11	C	CATN7-12-XD-D1CB-JU61R17-L11	0
	1.5	2	1	30	CATN7-12-XD-D1CB-JU61G17-L11	C	CATN7-12-XD-D1CB-JU61R17-L11	0
	2	2	1	30	CATN7-12-XD-D1CB-JU61G17-L11	C	CATN7-12-XD-D1CB-JU61R17-L11	0
0	3	2	1	30	CATN7-16-XD-D1DB-JU61G17-L11	C	CATN7-16-XD-D1DB-JU61R17-L11	0
	5	2	1	30	CATN7-16-XD-D1DB-JU61G17-L11	C	CATN7-16-XD-D1DB-JU61R17-L11	0
1	7.5	2	1	30	CATN7-37-XD-D1ED-JU61G17-L11	C	CATN7-37-XD-D1ED-JU61R17-L11	0
	10	2	1	30	CATN7-37-XD-D1ED-JU61G17-L11	C	CATN7-37-XD-D1ED-JU61R17-L11	0
2	15	2	1	30	CATN7-43-XD-D1FD-JU61G17-L11	C	CATN7-43-XD-D1FD-JU61R17-L11	0
	20	2	1	30	CATN7-43-XD-D1FD-JU61G17-L11	C	CATN7-43-XD-D1FD-JU61R17-L11	0
	25	2	1	60	CATN7-43-XD-D1FD-JU62G17-L11	C	CATN7-43-XD-D1FD-JU62R17-L11	0
	30	2	1	60	CATN7-85-XD-EGE-JU62G17-L11	D3	CATN7-85-XD-EGE-JU62R17-L11	0
3	40	2	1	60	CATN7-85-XD-EGE-JU62G17-L11	D3	CATN7-85-XD-EGE-JU62R17-L11	0
	50	2	1	100	CATN7-85-XD-EGE-JU63G17-L11	D3	CATN7-85-XD-EGE-JU63R17-L11	0

Full Voltage Non-Reversing (FVNR) Features include:

- NEMA-sized CAN7 contactor
- Three-Phase CEP7 Electronic Overload Relay
- Control Circuit Transformer
- Hand-Off-Auto (H-O-A) selector switch
- Red Run pilot light
- 2-NO and 1-NC auxiliaries for customer use
- Class CC Fuse holder as fused primary of CCT
- UL98 non-fusible L11 disconnect switch
- Reset pushbutton

- ① HP and NEMA size selection shown for 460V ratings only. Contact your Sprecher + Schuh representative for other voltage application.
- ② Contactors are equipped with number and type of auxiliaries indicated. See page C108 to order additional or different auxiliary contacts.
- ③ Fusible combo starter uses the L11 Disconnect. Fuse clips accept "J" type fuses. Power fuses not supplied.
- ④ A Red and Yellow Handle may be selected instead of the standard Black handle. Change "JF" to "LF" in catalog number.
- ⑤ HP and NEMA size selection shown for 575V ratings only. Contact your Sprecher + Schuh representative for other voltage application.
- ⑥ Dimensional information starts on page C122.

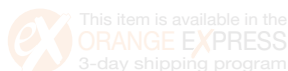

Explosion-proof Starters

Safe and reliable starting in hazardous applications

C

Explosion-Proof Starters

ISO9001, UL508 & UL1203 (NNNY) 
ATEX
Certified Panel Shop



Explosion Proof motor control panel mounted directly to motor and pump frame.

Sprecher + Schuh offers explosion-proof starters for environments covered by the following classifications:

NEMA: Type 4/4X, 7BCD, 9EFG

NEC: Class I, Div. 1 Groups B, C, D
Class II, Div. 1 Groups E, F, G
Class III

UL: Standard 1203
Hazardous (Classified)
Locations

CSA: Standard 22.2 No. 25 & 30

Explosion-proof combination starters also comply with NEMA Type 3, 3R, 4 & 4X. Optional ATEX certification is available in Class I, Zone 1, AExd IIB, Exd IIB+H2, IEXEx.

NEMA Type 4, 4X, 7, & 9 protection

NEMA Type 7 enclosures are designed to provide protection against an internal explosion when operated in a hazardous gas environment. NEMA Type 9 enclosures protect from internal explosion in a hazardous dust environment.

Both types must also prevent enclosed heat generating mechanisms from causing external surfaces to reach temperatures capable of igniting explosive gas-air mixtures in the surrounding atmosphere. Sprecher + Schuh explosion-proof starters meet all requirements of both classifications. Inclusive with the selection of these explosion proof starters is a gasket inserted into the flange of the enclosure. This included gasket also gives the enclosures a NEMA Type 4 watertight and NEMA Type 4X corrosion resistance approval.

Starting with the best

At the heart of all explosion-proof starters is Sprecher + Schuh's CAT7 and CAT9 line of motor starters. These starters are compact and offer intermediate sizes to better match specific motor requirements. This equates to generous wiring space and less wasted horsepower capacity.

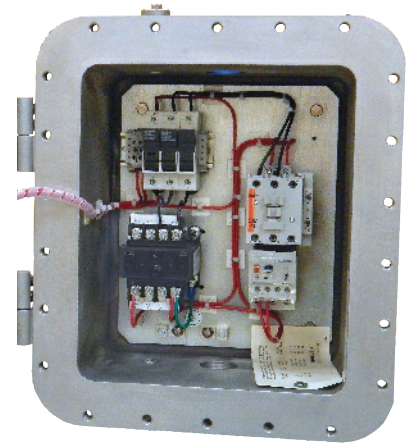

Top line protection...

Explosion Proof starters are equipped with Sprecher + Schuh's CEP7 solid state overload relay standard. Unlike traditional overload relays that indirectly sense motor current through heater elements, CEP7 solid state overload relays measure motor current directly through integrated current transformers and on board electronics. The electronics provide numerous advantages over electromechanical relays.

Combination starters for protection and convenience

Explosion-proof combination starters can include either a UL489 approved Thermal Magnetic Circuit Breaker (MCCB) or non-fusible disconnect. The MCCB utilizes the instantaneous trip ability of a magnetic breaker for short circuit currents combined with the overload tolerance of thermal circuit breakers for normal starting demands. An MCCB can also be quickly reset after the fault has been cleared.

A molded case switch (MCS) is used in applications requiring only a non-fused disconnect.

Series CAT7 & CAT9

Maximum Horsepower Three Phase				Without Short Circuit Protection	DIM	MCCB Amps	With Thermal Magnetic Circuit Breaker (MCCB)	DIM	With Non Fusible Disconnect	DIM
200V	230V	460V	575V	Catalog No.	①		Catalog No.	①	Catalog No.	①
2	2	5	5	CAT7-30-*◆-E0	A7	15	CAT7-30-*◆-TB15E0	E7		
2	2	5	5	CAT7-30-*◆-E0	A7	15	CAT7-30-*◆-TBH15E0	E7		
3	3	7.5	10	CAT7-30-*◆-E0	A7	20	CAT7-30-*◆-TB20E0	E7		
3	3	7.5	10	CAT7-30-*◆-E0	A7	20	CAT7-30-*◆-TBH20E0	E7		
~	5	10	~	CAT7-30-*◆-E0	A7	30	CAT7-30-*◆-TB30E0	E7		
5	~	~	15	CAT7-30-*◆-E0	A7	35	CAT7-30-*◆-TB35E0	E7		
5	~	~	15	CAT7-30-*◆-E0	A7	35	CAT7-30-*◆-TBH35E0	E7		
~	7.5	15	20	CAT7-30-*◆-E0	A7	40	CAT7-30-*◆-TB40E0	E7		
~	7.5	15	20	CAT7-30-*◆-E0	A7	40	CAT7-30-*◆-TBH40E0	E7		
7.5	10	20	25	CAT7-30-*◆-E0	A7	50	CAT7-30-*◆-TB50E0	E7		
7.5	~	20	25	CAT7-30-*◆-E0	A7	50	CAT7-30-*◆-TBH50E0	E7		
10	10	25	30	CAT7-37-*◆-E0	A7	50	CAT7-37-*◆-TB50E0	E7		
10	10	~	30	CAT7-37-*◆-E0	A7	50	CAT7-37-*◆-TBH50E0	E7		
~	~	30	~	CAT7-43-*◆-E0	A7	70	CAT7-43-*◆-TB70E0	E7		
~	15	~	~	CAT7-43-*◆-E0	A7	80	CAT7-43-*◆-TB80E0	E7		
15	20	40	40	CAT7-55-*◆-E0	A7	80	CAT7-55-*◆-TB80E0	E7		
15	20	40	40	CAT7-55-*◆-E0	A7	80	CAT7-55-*◆-TBH80E0	E7		
~	~	~	40	CAT7-60-*◆-E0	A7	80	CAT7-60-*◆-TB80E0	F7		
~	~	~	40	CAT7-60-*◆-E0	A7	80	CAT7-60-*◆-TBH80E0	F7		
15	20	40	50	CAT7-60-*◆-E0	A7	100	CAT7-60-*◆-TB100E0	F7		
15	20	40	50	CAT7-60-*◆-E0	A7	100	CAT7-60-*◆-TBH100E0	F7		
20	25	50	60	CAT7-72-*◆-E0	A7	125	CAT7-72-*◆-TB125E0	F7		
20	25	50	60	CAT7-72-*◆-E0	A7	125	CAT7-72-*◆-TBH125E0	F7		
25	30	60	~	CAT7-85-*◆-E0	A7	125	CAT7-85-*◆-TB125E0	F7		
~	~	~	75	CAT7-97-*◆-E0	A7	150	CAT7-97-*◆-TB150E0	F7		
~	~	~	75	CAT7-97-*◆-E0	A7	150	CAT7-97-*◆-TBH150E0	F7		
30	~	75	~	CAT7-97-*◆-E0	A7	175	CAT7-97-*◆-TB175E0	F7		
30	~	75	~	CAT9-116-*◆-E0	B7	175	CAT9-116-*◆-TB175E0	G7		
~	40	~	100	CAT9-116-*◆-E0	B7	200	CAT9-116-*◆-TB200E0	G7		
40	~	100	125	CAT9-146-*◆-E0	B7	225	CAT9-146-*◆-TB225E0	G7		
~	50	~	~	CAT9-146-*◆-E0	B7	250	CAT9-146-*◆-TB250E0	G7		
50	60	125	150	CAT9-190-*◆-E0	C7	300	CAT9-190-*◆-TB300E0	H7		
60	75	150	200	CAT9-205-*◆-E0	C7	350	CAT9-205-*◆-TB350E0	H7		
75	~	175	~	CAT9-265-*◆-E0	D7	400	CAT9-265-*◆-TB400E0	H7		
~	100	200	250	CAT9-265-*◆-E0	D7	450	CAT9-265-*◆-TB450E0	H7		
100	~	~	~	CAT9-305-*◆-E0	D7	500	CAT9-305-*◆-TB500E0	H7		
~	125	250	300	CAT9-305-*◆-E0	D7	600	CAT9-305-*◆-TB600E0	H7		
~	~	~	350	CAT9-370-*◆-E0	D7	600	CAT9-370-*◆-TB600E0	H7		
125	150	300	~	CAT9-370-*◆-E0	D7	700	CAT9-370-*◆-TB700E0	H7		
125	150	~	400	CAT9-400-EI-*◆-E0	D7	700	CAT9-400-EI-*◆-TB700E0	H7		
~	~	350	~	CAT9-400-EI-*◆-E0	D7	800	CAT9-400-EI-*◆-TB800E0	H7		
150	~	~	~	CAT9-460-EI-*◆-E0	D7	800	CAT9-460-EI-*◆-TB800E0	H7		
~	200	400	500	CAT9-460-EI-*◆-E0	D7	1000	CAT9-460-EI-*◆-TB1000E0	H7		
200	~	~	600	CAT9-580-EI-*◆-E0	R/F	1000	CAT9-580-EI-*◆-TB1000E0	R/F		
~	250	500	~	CAT9-580-EI-*◆-E0	R/F	1200	CAT9-580-EI-*◆-TB1200E0	R/F		

To order, select equivalent Thermal-Magnetic Circuit Breaker catalog number from this chart. Specify on order, "With molded case switch."

NOTE: Catalog numbers and enclosure dimensions reflect contactors with AC coils. For DC coils, select Coil Code from the DC Coil Code table on page C104 and follow the instructions for modifying catalog numbers.

Larger sizes and reversing starters available. Contact your Sprecher + Schuh representative.

Ordering Instructions

Specify Catalog Number	
Replace (*) with Coil Code	See page C104
Replace (◆) with O/L Relay	See pages C105-C106
Factory Modifications available	See pages C107-C111

- ① Dimensional information starts on page C122.
- ② Enclosures have gaskets for outdoor use (Type 4).
- ③ Applicable to 600Y/347V only.
- ④ The short circuit and kAIC is relegated to the contactor's 10kA. Contact your Sprecher + Schuh representative for a higher kAIC.
- ⑤ CAT9-116...CAT9-370 starters are available with "EI" option for PLC interface. Change catalog number to include "-EI". Example: CAT9-116-*◆-TB175E0 becomes CAT9-116-EI-*◆-TB175E0.

Explosion-Proof Starters

Pilot Device Kits – NEMA Type 4/4X/7/9 Applications (For use with Explosion Proof Enclosures)

Kits	Description	Contact Blocks included		Catalog Number
		NO	NC	
	START Pushbutton Green, Non-illuminated, momentary, with legend ❶❷	1	0	XHPB-BT4-XNP
	STOP Pushbutton Red, Non-illuminated, momentary, with legend ❶❷	0	1	XHPB-BT5-XNP
	DUAL Pushbutton Non-illuminated, momentary	1	1	XHDPB-BT1A
	OFF-ON Selector Switch Non-illuminated, maintained, with legend	1	0	XHSS-1-BT4-XNP/OFF-ON
	HAND-AUTO Selector Switch Non-illuminated, maintained, with legend	1	1	XHSS-1-BT1A-XNP/HAND-AUTO
	HAND-OFF-AUTO Selector Switch Non-illuminated, maintained, with legend	2	0	XHSS-3-BT2-XNP/HAND-OFF-AUTO
	FWD-OFF-REV Selector Switch Non-illuminated, maintained, with legend	2	0	XHSS-3-BT2-XNP/FWD-OFF-REV
	RED EMERGENCY STOP Pushbutton Non-illuminated, maintained push-pull, with legend	1	1	XHPPM-BT1A-XNP/ESTOP
	Mechanical RESET Pushbutton	0	0	XRБ
	GUARDED Pilot Light ❸ 120V incandescent, screw terminations	Amber Blue Clear Green Red White		XLAT-GH XLBT-GH XLCT-GH XLGT-GH XLRT-GH XLWT-GH
	PUSHBUTTON LOCKOUT - Accessory Padlock device to activate pushbutton	~		XHPL
	OPERATOR PROTECTIVE BOOT Rubber push button cap	Green Red		XBG XBR
	OPERATOR PROTECTIVE BOOT Rubber selector switch cap	Black		XBSB
	COMBINATION BREATHER/DRAIN ❹ Install on top of enclosure for Breather Install in bottom of enclosure for Drain	Stainless steel		XDBH2

❶ Legend Plates are anodized aluminum with engraved letters on black background (XNP).
❷ STOP has red background. START has green background.

❸ One of the NPSM hole locations on the A7 dimensional enclosure could create the need for a short pilot light. Refer to factory for details.
❹ Requires purchase of 2 pcs for application of both Breather and Drain.

Multispeed Starters

Versatile starters for any multispeed motor or application



Sprecher + Schuh multispeed starters can produce multiple constant speeds by specially arranging the windings of multispeed motors. Motors with two separate windings or one reconnectable winding can be used.

All Sprecher + Schuh multispeed starters feature our CAT7 and CAT9 motor starters. These compact starters offer intermediate sizes to better match specific motor requirements. This equates to generous wiring space and less wasted horsepower capacity. Advanced CEP7 solid state overload relays are used with starters. See Section B in this catalog for a full description of these excellent motor protection relays.

Choose the right starter for your application

Multispeed motors fall into three types, all with differing torque characteristics. Selecting the proper type depends on the connected load.

Constant Torque motors deliver the same torque at each speed, and horsepower varies directly with the speed. Typical applications include reciprocating pumps, conveyors, mills and mixers.

Constant Horsepower motors deliver the same horsepower at each speed and the torque varies inversely with the speed. Typical applications include machine tools such as drills, lathes, mills, punch presses and saws.

Variable Torque (variable horsepower) motors deliver a torque that varies directly with the speed and the horsepower varies directly with the square of the speed. Typical applications include centrifugal pumps, fans and blowers.

Control options

The four common forms of control for multispeed starters are known as selective, compelling, progressive and decelerating. Standard multispeed starters are wired for selective control. The other control options are available as factory modifications.

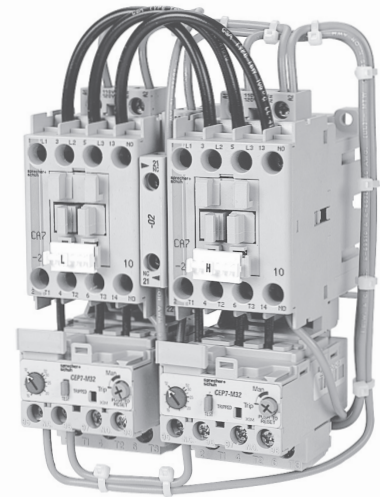

Selective Control permits starting the motor on any desired speed. To increase the speed of a running motor, press the desired speed button. To change to a lower speed, the STOP button must be pressed before selecting a new speed.

Compelling Control requires that the motor always be started at the lowest speed. To reach higher speeds, the push buttons must be operated in the speed sequence. To change to a lower speed, the STOP button must be pressed before selecting a new speed.

Progressive Control provides automatic, timed acceleration of the motor to the selected speed by energizing the windings progressively from the lowest to the desired speed. To change to a lower speed, the STOP button must be pressed before selecting a new speed.

Decelerating Control provides automatic time delay to a lower speed. This type of control allows the motor to decelerate from a high speed before automatically restarting the motor in a lower speed. Decelerating Control prevents damage to the motor or machine when high inertia loads are switched to a lower speed.

Contact your Sprecher + Schuh representative for more information.

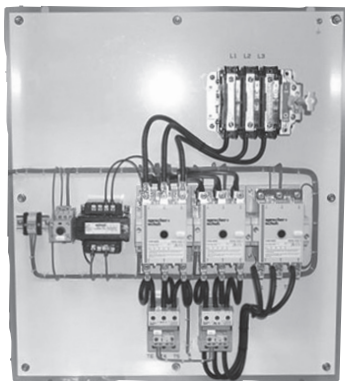

Custom 2-speed, 1-winding combination starter with control transformer and deceleration relay, mounted in a Type-1 enclosure

Two Separate Windings CAZTT7/CAZTT9 & CAZHT7/CAZHT9

Maximum Horsepower Three Phase				Open Type	Type 1 General Purpose	D I M	Type 12 [Type 3R ②] Industrial Dusttight	D I M	Type 4 Watertight	D I M	Type 4X Watertight Corr Resist Non-metallic	D I M
200V	230V	460V	575V									
Constant or Variable Torque - CAZTT ③												
				CAZTT	CAZTT		CAZTT		CAZTT		CAZTT	
2	2	5	7 1/2	7-9-*◆	7-9-*◆-G0	M	7-9-*◆-D0	M	7-9-*◆-W0	N	7-9-*◆-C0	U1
3	3	7 1/2	10	7-12-*◆	7-12-*◆-G0	M	7-12-*◆-D0	M	7-12-*◆-W0	N	7-12-*◆-C0	U1
5	5	10	15	7-16-*◆	7-16-*◆-G0	M	7-16-*◆-D0	M	7-16-*◆-W0	N	7-16-*◆-C0	U1
5	7 1/2	15	15	7-23-*◆	7-23-*◆-G0	M	7-23-*◆-D0	M	7-23-*◆-W0	N	7-23-*◆-C0	U1
7 1/2	10	20	25	7-30-*◆	7-30-*◆-G0	M	7-30-*◆-D0	M	7-30-*◆-W0	O	7-30-*◆-C0	U1
10	10	25	30	7-37-*◆	7-37-*◆-G0	M	7-37-*◆-D0	M	7-37-*◆-W0	O	7-37-*◆-C0	U1
10	15	30	30	7-43-*◆	7-43-*◆-G0	M	7-43-*◆-D0	M	7-43-*◆-W0	O	7-43-*◆-C0	U1
15	20	40	40	7-55-*◆	7-55-*◆-G0	M	7-55-*◆-D0	M	7-55-*◆-W0	O	7-55-*◆-C0	U1
15	20	40	50	7-60-*◆	7-60-*◆-G0	C	7-60-*◆-D0	O	7-60-*◆-W0	O	7-60-*◆-C0	V1
20	25	50	60	7-72-*◆	7-72-*◆-G0	C	7-72-*◆-D0	O	7-72-*◆-W0	O	7-72-*◆-C0	V1
25	30	60	60	7-85-*◆	7-85-*◆-G0	C	7-85-*◆-D0	O	7-85-*◆-W0	O	7-85-*◆-C0	V1
30	30	75	75	7-97-*◆	7-97-*◆-G0	C	7-97-*◆-D0	O	7-97-*◆-W0	O	7-97-*◆-C0	V1
30	40	75	100	9-116-*◆◆	9-116-*◆-G0	E2	9-116-*◆-D0	R2	9-116-*◆-W0	R2	9-116-*◆-C0	W2
40	50	100	125	9-146-*◆◆	9-146-*◆-G0	G	9-146-*◆-D0	T	9-146-*◆-W0	T	9-146-*◆-C0	X1
Constant Horsepower - CAZHT ③												
				CAZHT	CAZHT		CAZHT		CAZHT		CAZHT	
1 1/2	1 1/2	3	5	7-9-*◆	7-9-*◆-G0	M	7-9-*◆-D0	M	7-9-*◆-W0	N	7-9-*◆-C0	U1
2	2	5	7 1/2	7-12-*◆	7-12-*◆-G0	M	7-12-*◆-D0	M	7-12-*◆-W0	N	7-12-*◆-C0	U1
3	3	7 1/2	10	7-16-*◆	7-16-*◆-G0	M	7-16-*◆-D0	M	7-16-*◆-W0	N	7-16-*◆-C0	U1
3	5	10	10	7-23-*◆	7-23-*◆-G0	M	7-23-*◆-D0	M	7-23-*◆-W0	N	7-23-*◆-C0	U1
5	7 1/2	15	20	7-30-*◆	7-30-*◆-G0	M	7-30-*◆-D0	M	7-30-*◆-W0	O	7-30-*◆-C0	U1
7 1/2	7 1/2	20	25	7-37-*◆	7-37-*◆-G0	M	7-37-*◆-D0	M	7-37-*◆-W0	O	7-37-*◆-C0	U1
7 1/2	10	25	25	7-43-*◆	7-43-*◆-G0	M	7-43-*◆-D0	M	7-43-*◆-W0	O	7-43-*◆-C0	U1
10	15	30	30	7-55-*◆	7-55-*◆-G0	M	7-55-*◆-D0	M	7-55-*◆-W0	O	7-55-*◆-C0	U1
10	15	30	40	7-60-*◆	7-60-*◆-G0	C	7-60-*◆-D0	O	7-60-*◆-W0	O	7-60-*◆-C0	V1
15	20	40	50	7-72-*◆	7-72-*◆-G0	C	7-72-*◆-D0	O	7-72-*◆-W0	O	7-72-*◆-C0	V1
20	25	50	50	7-85-*◆	7-85-*◆-G0	C	7-85-*◆-D0	O	7-85-*◆-W0	O	7-85-*◆-C0	V1
25	25	60	60	7-97-*◆	7-97-*◆-G0	C	7-97-*◆-D0	O	7-97-*◆-W0	O	7-97-*◆-C0	V1
~	30	60	75	9-116-*◆◆	9-116-*◆-G0	E2	9-116-*◆-D0	R2	9-116-*◆-W0	R2	9-116-*◆-C0	W2
30	40	75	100	9-146-*◆◆	9-146-*◆-G0	G	9-146-*◆-D0	T	9-146-*◆-W0	T	9-146-*◆-C0	X1

Larger sizes available. Contact your Sprecher + Schuh representative.

NOTE: Catalog numbers and enclosure dimensions reflect contactors with AC coils. For DC coils, select Coil Code from the DC Coil Code table on page C104 and follow the instructions for modifying catalog numbers.

- ① Dimensional information starts on page C122.
- ② For Type 3R outdoor applications, replace "D" in catalog number with an "R". Dimensions may change. For example number CAZTT7-23-*◆-D0 becomes CAZTT7-23-*◆-R0.

Ordering Instructions

Specify Catalog Number	
Replace (*) with Coil Code	See page C104 See pages C105-C106 See pages C107-C111
Replace (◆) with O/L Relay for each speed	
Factory Modifications available	

- ③ All standard multispeed starters are wired for selective control. For compelling, progressive or automatic acceleration control, see Factory Modifications.
- ④ CAT9-116...CAT9-370 starters are available with "EI" option for PLC interface. Change catalog number to include "-EI". Example: CAZTT9-116-*◆-G0 becomes CAZTT9-116-EI-*◆-G0.

One Reconnectable Winding CAETT7/CAETT9 & CAEHT7/CAEHT9

Maximum Horsepower Three Phase				Open Type	Type 1 General Purpose	D I M	Type 12 [Type 3R] Industrial Dusttight	D I M	Type 4 Watertight	D I M	Type 4X Watertight Corr Resist Non-metallic	D I M
200V	230V	460V	575V									
Constant or Variable Torque - CAETT												
				CAETT	CAETT		CAETT		CAETT		CAETT	
2	2	5	7 1/2	7-9-*◆	7-9-*◆-G0	C	7-9-*◆-D0	O	7-9-*◆-W0	O	7-9-*◆-C0	V1
3	3	7 1/2	10	7-12-*◆	7-12-*◆-G0	C	7-12-*◆-D0	O	7-12-*◆-W0	O	7-12-*◆-C0	V1
5	5	10	15	7-16-*◆	7-16-*◆-G0	C	7-16-*◆-D0	O	7-16-*◆-W0	O	7-16-*◆-C0	V1
5	7 1/2	15	15	7-23-*◆	7-23-*◆-G0	C	7-23-*◆-D0	O	7-23-*◆-W0	O	7-23-*◆-C0	V1
7 1/2	10	20	25	7-30-*◆	7-30-*◆-G0	C	7-30-*◆-D0	O	7-30-*◆-W0	O	7-30-*◆-C0	V1
10	10	25	30	7-37-*◆	7-37-*◆-G0	C	7-37-*◆-D0	O	7-37-*◆-W0	O	7-37-*◆-C0	V1
10	15	30	30	7-43-*◆	7-43-*◆-G0	C	7-43-*◆-D0	O	7-43-*◆-W0	O	7-43-*◆-C0	V1
15	20	40	40	7-55-*◆	7-55-*◆-G0	C	7-55-*◆-D0	O	7-55-*◆-W0	O	7-55-*◆-C0	V1
15	20	40	50	7-60-*◆	7-60-*◆-G0	D	7-60-*◆-D0	O	7-60-*◆-W0	O	7-60-*◆-C0	W1
20	25	50	60	7-72-*◆	7-72-*◆-G0	D	7-72-*◆-D0	Q	7-72-*◆-W0	Q	7-72-*◆-C0	W1
25	30	60	60	7-85-*◆	7-85-*◆-G0	D	7-85-*◆-D0	Q	7-85-*◆-W0	Q	7-85-*◆-C0	W1
30	30	75	75	7-97-*◆	7-97-*◆-G0	D	7-97-*◆-D0	Q	7-97-*◆-W0	Q	7-97-*◆-C0	W1
30	40	75	100	9-116-*◆①	9-116-*◆-G0①	G	9-116-*◆-D0①	T	9-116-*◆-W0①	T	9-116-*◆-C0①	A2
40	50	100	125	9-146-*◆①	9-146-*◆-G0①	G	9-146-*◆-D0①	T	9-146-*◆-W0①	T	9-146-*◆-C0①	A2
Constant Horsepower - CAEHT												
				CAEHT	CAEHT		CAEHT		CAEHT		CAEHT	
1 1/2	1 1/2	3	5	7-9-*◆	7-9-*◆-G0	C	7-9-*◆-D0	O	7-9-*◆-W0	O	7-9-*◆-C0	V1
2	2	5	7 1/2	7-12-*◆	7-12-*◆-G0	C	7-12-*◆-D0	O	7-12-*◆-W0	O	7-12-*◆-C0	V1
3	3	7 1/2	10	7-16-*◆	7-16-*◆-G0	C	7-16-*◆-D0	O	7-16-*◆-W0	O	7-16-*◆-C0	V1
3	5	10	10	7-23-*◆	7-23-*◆-G0	C	7-23-*◆-D0	O	7-23-*◆-W0	O	7-23-*◆-C0	V1
5	7 1/2	15	20	7-30-*◆	7-30-*◆-G0	C	7-30-*◆-D0	O	7-30-*◆-W0	O	7-30-*◆-C0	V1
7 1/2	7 1/2	20	25	7-37-*◆	7-37-*◆-G0	C	7-37-*◆-D0	O	7-37-*◆-W0	O	7-37-*◆-C0	V1
7 1/2	10	25	25	7-43-*◆	7-43-*◆-G0	C	7-43-*◆-D0	O	7-43-*◆-W0	O	7-43-*◆-C0	V1
10	15	30	30	7-55-*◆	7-55-*◆-G0	C	7-55-*◆-D0	O	7-55-*◆-W0	O	7-55-*◆-C0	V1
10	15	30	40	7-60-*◆	7-60-*◆-G0	D	7-60-*◆-D0	O	7-60-*◆-W0	O	7-60-*◆-C0	W1
15	20	40	50	7-72-*◆	7-72-*◆-G0	D	7-72-*◆-D0	Q	7-72-*◆-W0	Q	7-72-*◆-C0	W1
20	25	50	50	7-85-*◆	7-85-*◆-G0	D	7-85-*◆-D0	Q	7-85-*◆-W0	Q	7-85-*◆-C0	W1
25	25	60	60	7-97-*◆	7-97-*◆-G0	D	7-97-*◆-D0	Q	7-97-*◆-W0	Q	7-97-*◆-C0	W1
~	30	60	75	9-116-*◆①	9-116-*◆-G0①	G	9-116-*◆-D0①	T	9-116-*◆-W0①	T	9-116-*◆-C0①	A2
30	40	75	100	9-146-*◆①	9-146-*◆-G0①	G	9-146-*◆-D0①	T	9-146-*◆-W0①	T	9-146-*◆-C0①	A2

Larger sizes available. Contact your Sprecher + Schuh representative.

NOTE: Catalog numbers and enclosure dimensions reflect contactors with AC coils. For DC coils, select Coil Code from the DC Coil Code table on page C104 and follow the instructions for modifying catalog numbers.

- ① Dimensional information starts on page C122.
- ② For Type 3R outdoor applications, replace "D" in catalog number with an "R". Dimensions may change. For example number CAETT7-23-*◆-D0 becomes CAETT7-23-*◆-R0.

Ordering Instructions

Specify Catalog Number	
Replace (*) with Coil Code	See page C104 See pages C105-C106 See pages C107-C111
Replace (◆) with O/L Relay	
Factory Modifications available	

- ③ All standard multispeed starters are wired for selective control. For compelling, progressive or automatic acceleration control, see Factory Modifications.
- ④ CAT9-116...CAT9-370 starters are available with "EI" option for PLC interface. Change catalog number to include "-EI". Example: CAEHT9-116-*◆-G0 becomes CAEHT9-116-EI-*◆-G0.

Combination Multi-Speed Starter Options Chart

Circuit Breaker or Disconnect Switch	Enclosure Type					
		7-9 7-12 7-16	7-23 7-30	7-37 7-43 7-55	7-60 7-72 7-85 7-97	9-116 (-EI) 9-146 (-EI)
Thermal Magnetic Circuit Breaker	Type 1					
	Type 4/4X					
	Type 12					
Non Fusible Disconnect	Type 1					
	Type 4/4X					
	Type 12					
Fusible Disconnect - 30 Amp	Type 1					
	Type 4/4X					
	Type 12					
Fusible Disconnect - 60 Amp	Type 1					
	Type 4/4X					
	Type 12					
Fusible Disconnect - 100 Amp	Type 1					
	Type 4/4X					
	Type 12					
Fusible Disconnect - 200 Amp	Type 1					
	Type 4/4X					
	Type 12					

C
Multi-Speed Starters

❶ Refer to pages C4-C5 for information on modifying standard multispeed catalog number to combination type or contact Sprecher + Schuh Technical Support.

Reduced Voltage Starters

Controlled starting for low in-rush and smooth operation



Sprecher + Schuh reduced voltage starters are designed for starting squirrel cage induction motors where the starting current of a motor is likely to exceed local power company restrictions, interfere with plant operations or where the load may be damaged by high starting torques.

Starting with the best

All Sprecher + Schuh reduced voltage starters feature our CAT7 and CAT9 line of motor starters. These compact starters offer intermediate sizes to better match specific motor requirements. This equates to generous wiring space and less wasted horsepower capacity. Our advanced CEP7 solid state overload relays are used with starters. See Section B in this catalog for a full description of these excellent motor protection relays.

Choosing the right reduced voltage method

Autotransformer Starter – At starting, three autotransformers (one for each phase) are automatically connected in series with the motor. The voltage at the motor is reduced to either 50%, 65% or 80% depending on which voltage tap was selected. After a timed interval, a contactor connects the motor across-the-

line and shorts out the autotransformers. Factory standard autotransformers are rated for “medium duty” as defined by NEMA.

Part Winding Starter – This type of starting requires that the motor winding be in two equal parts, and that at least six terminal leads be provided on the motor. At starting, the controller is arranged to connect one section of the winding to the supply lines. After a timed interval, a second contactor connects the other section of the motor winding to the supply lines, in parallel with the first.

Wye-Delta Starter – This type of starting requires a special wye-delta motor. Both ends of the motor’s three windings are brought out so they are accessible for reconnecting from wye to delta. At starting, the controller connects the motor in the wye configuration. After a timed interval, a second contactor connects the motor in a delta configuration.

The reference chart below compares all three reduced voltage starting methods and contrasts them with across-the-line starting.

Reduced Voltage Comparison Table

Type of Starter	Starting Characteristics			Advantages	Disadvantages
	Voltage @ Motor	Line Current	Starting Torque		
Across-The-Line	100%	100%	100%	<ul style="list-style-type: none"> Least expensive. Simple to maintain. Highest starting torque. Readily available. Lowest installation cost. 	<ul style="list-style-type: none"> High starting inrush may exceed limits of local utility or electrical system. Starting torque may be too high for the application. Limited to smaller horsepower motors.
Autotransformer	80% 65% 50%	64% 42% 25%	64% 42% 25%	<ul style="list-style-type: none"> Provides highest torque per ampere of line current. Three different taps on transformer permit adjustment of starting voltage. Suitable for long starting periods. Closed transition starting. Uses standard motor.. 	<ul style="list-style-type: none"> In lower horsepower, is the most expensive design. Low power factor. Large physical size. High installation cost.
Part Winding	100%	65%	42%	<ul style="list-style-type: none"> Least expensive of all reduced voltage starters. Closed transition starting. Small physical size. Most dual voltage motors can be used. Simple design. Low installation cost. 	<ul style="list-style-type: none"> Poor torque efficiency Unsuited for high inertia, long starting loads. Motor may not accelerate during start period. Requires special motor design for voltages higher than 230 volts.
Wye-Delta	100%	33%	33%	<ul style="list-style-type: none"> Suitable for high inertia, long acceleration loads. High torque efficiency. Ideal for especially stringent inrush restrictions. Ideal for frequent starts. 	<ul style="list-style-type: none"> Requires special motor design. Low starting torque. Open transition (closed available). Complex design.

Autotransformer 10 HP to 125 HP (Closed Transition - Type 1 General Purpose Enclosure) ④

Maximum H.P.	3 Ø Volts	Without Short Circuit Protection Catalog No.	D I M MCCB Amps	With Thermal Magnetic Circuit Breaker (MCCB) Catalog No.	D I M	Fuse Clip Amps	With Fusible Disconnect ②⑤ Catalog No.	D I M
		CAAT		CAAT			CAAT	
10	200	BA7-37-*◆-G0	F 50	BA7-37-*◆-TB50G0	S	60	BA7-37-*◆-JF62G0	S
	230	BB7-37-*◆-G0	F 50	BB7-37-*◆-TB50G0	S	60	BB7-37-*◆-JF62G0	S
15	200	CA7-60-*◆-G0	F 100	CA7-60-*◆-TB100G0	S	100	CA7-60-*◆-JF63G0	S
	230	CB7-43-*◆-G0	F 80	CB7-43-*◆-TB80G0	S	100	CB7-43-*◆-JF63G0	S
20	200	DA7-72-*◆-G0	F 125	DA7-72-*◆-TB125G0	S	100	DA7-72-*◆-JF63G0	S
	230	DB7-60-*◆-G0	F 100	DB7-60-*◆-TB100G0	S	100	DB7-60-*◆-JF63G0	S
25	200	EA7-85-*◆-G0	F 125	EA7-85-*◆-TB125G0	S	200	EA7-85-*◆-JF64G0	S
	230	EB7-72-*◆-G0	F 125	EB7-72-*◆-TB125G0	S	100	EB7-72-*◆-JF63G0	S
	460	EC7-37-*◆-G0	F 50	EC7-37-*◆-TB50G0	S	60	EC7-37-*◆-JF62G0	S
30	200	FA7-97-*◆-G0	F 175	FA7-97-*◆-TB175G0 ④	S	200	FA7-97-*◆-JF64G0	I
	230	FB7-85-*◆-G0	F 125	FB7-85-*◆-TB125G0	S	200	FB7-85-*◆-JF64G0	S
	460	FC7-43-*◆-G0	F 70	FC7-43-*◆-TB70G0	S	60	FC7-43-*◆-JF62G0	S
	575	FD7-37-*◆-G0	F 50	FD7-37-*◆-TBH50G0	S	60	FD7-37-*◆-JF62G0	S
40	200	GA9-146-*◆-G0 ⑦	H 225	GA9-146-*◆-TB225G0 ⑦	J	200	GA9-146-*◆-JF64G0 ⑦	J
	230	GB9-116-*◆-G0 ⑦	H 200	GB9-116-*◆-TB200G0 ⑦	J	200	GB9-116-*◆-JF64G0 ⑦	J
	460	GC7-60-*◆-G0	F 100	GC7-60-*◆-TB100G0	S	100	GC7-60-*◆-JF63G0	S
	575	GD7-60-*◆-G0	F 80	GD7-60-*◆-TBH80G0	S	60	GD7-60-*◆-JF62G0	S
50	200	HA9-190-*◆-G0 ⑦	I 300	HA9-190-*◆-TB300G0 ⑦	J	400	HA9-190-*◆-JF65G0 ⑦	K3
	230	HB9-146-*◆-G0 ⑦	I 250	HB9-146-*◆-TB250G0 ⑦	J	200	HB9-146-*◆-JF64G0 ⑦	J
	460	HC7-72-*◆-G0	F 125	HC7-72-*◆-TB125G0	S	100	HC7-72-*◆-JF63G0	S
	575	HD7-60-*◆-G0	F 100	HD7-60-*◆-TBH100G0	S	100	HD7-60-*◆-JF63G0	S
60	200	JA9-205-*◆-G0 ⑦	J 350	JA9-205-*◆-TB350G0 ⑦	J	400	JA9-205-*◆-JF65G0 ⑦	K3
	230	JB9-190-*◆-G0 ⑦	I 300	JB9-190-*◆-TB300G0 ⑦	J	400	JB9-190-*◆-JF65G0 ⑦	K3
	460	JC7-85-*◆-G0	F 125	JC7-85-*◆-TB125G0	S	200	JC7-85-*◆-JF64G0	S
	575	JD7-72-*◆-G0	F 125	JD7-72-*◆-TBH125G0	S	100	JD7-72-*◆-JF63G0	S
75	200	KA9-265-*◆-G0 ⑦	J 400	KA9-265-*◆-TB400G0 ⑦	K2	400	KA9-265-*◆-JF65G0 ⑦	K2
	230	KB9-205-*◆-G0 ⑦	J 350	KB9-205-*◆-TB350G0 ⑦	K2	400	KB9-205-*◆-JF65G0 ⑦	K2
	460	KC7-97-*◆-G0	F 175	KC7-97-*◆-TB175G0 ④	S	200	KC7-97-*◆-JF64G0	I
	575	KD7-97-*◆-G0	F 150	KD7-97-*◆-TBH150G0 ④	S	200	KD7-97-*◆-JF64G0	I
100	200	LA9-305-*◆-G0 ⑦	J2 500	LA9-305-*◆-TB500G0 ⑦	K2	600	LA9-305-*◆-JF66G0 ⑦	K2
	230	LB9-265-*◆-G0 ⑦	J 450	LB9-265-*◆-TB450G0 ⑦	K2	400	LB9-265-*◆-JF65G0 ⑦	K2
	460	LC9-146-*◆-G0 ⑦	I 225	LC9-146-*◆-TBH225G0 ⑦	J	200	LC9-146-*◆-JF64G0 ⑦	J
	575	LD9-116-*◆-G0 ⑦	H 200	LD9-116-*◆-TBH200G0 ⑦	J	200	LD9-116-*◆-JF64G0 ⑦	J
125	200	MA9-370-*◆-G0 ⑦	J2 700	MA9-370-*◆-TB700G0 ⑦	K2	600	MA9-370-*◆-JF66G0 ⑦	K2
	230	MB9-305-*◆-G0 ⑦	J2 600	MB9-305-*◆-TB600G0 ⑦	K2	600	MB9-305-*◆-JF66G0 ⑦	K2
	460	MC9-190-*◆-G0 ⑦	I 300	MC9-190-*◆-TB300G0 ⑦	J	400	MC9-190-*◆-JF65G0 ⑦	K3
	575	MD9-146-*◆-G0 ⑦	I 225	MD9-146-*◆-TBH225G0 ⑦	J	200	MD9-146-*◆-JF64G0 ⑦	J

Larger Horsepower Continued On Next Page →

NOTE: Catalog numbers and enclosure dimensions reflect contactors with AC coils. For DC coils, select Coil Code from the DC Coil Code table on page C104 and follow the instructions for modifying catalog numbers.

Ordering Instructions

Specify Catalog Number	
Replace (*) with Coil Code	See page C104
Replace (◆) with O/L Relay	See pages C105-C106
Factory Modifications available	See pages C107-C111

- ① Dimensional information starts on page C122.
- ② For Non-fusible Disconnect applications, replace the "JF" characters with "JU".
Example: CAATHC7-72-*◆-JF63G0 becomes CAATHC7-72-*◆-JU63G0.
- ③ Fuse clips sized for use with "J"-type fuses.
- ④ Other enclosures available. Contact your Sprecher + Schuh Representative.
- ⑤ A Red and Yellow Handle may be selected instead of the standard Gray and Black handle. Change "JF" to "LF" in catalog number.
- ⑥ The short circuit and kAIC is relegated to the contactor's 10kA. Contact your Sprecher + Schuh representative for a higher kAIC.
- ⑦ CAT9-116...CAT9-370 starters are available with "EI" option for PLC interface. Change catalog number to include "-EI". For example: CAATGB9-116-*◆-G0 becomes CAATGB9-116-EI-*◆-G0.

Autotransformer 150 HP to 1000 HP (Closed Transition - Type 1 General Purpose Enclosure) ④

Maximum H.P.	3 Ø Volts	Without Short Circuit Protection	D I M	MCCB Amps	With Thermal Magnetic Circuit Breaker (MCCB)	D I M	Fuse Clip Amps	With Fusible Disconnect ②③	D I M
		Catalog No.			Catalog No.			Catalog No.	
		CAAT			CAAT			CAAT	
150	200	NA9-460-EI-♦-◆-G0	J2	800	NA9-460-EI-♦-◆-TB800G0	R/F	800	NA9-460-EI-♦-◆-JF67G0	~
	230	NB9-370-♦-◆-G0 ④	J2	700	NB9-370-♦-◆-TB700G0 ④	K2	600	NB9-370-♦-◆-JF66G0 ④	K2
	460	NC9-205-♦-◆-G0 ④	I	350	NC9-205-♦-◆-TB350G0 ④	J	400	NC9-205-♦-◆-JF65G0 ④	K3
	575	ND9-190-♦-◆-G0 ④	I	300	ND9-190-♦-◆-TB300G0 ④	J	400	ND9-190-♦-◆-JF65G0 ④	K3
200	230	OB9-460-EI-♦-◆-G0	~	1000	OB9-460-EI-♦-◆-TB1000G0	~	800	OB9-460-EI-♦-◆-JF67G0	~
	460	OC9-265-♦-◆-G0 ④	J	450	OC9-265-♦-◆-TB450G0 ④	K2	400	OC9-265-♦-◆-JF65G0 ④	K2
	575	OD9-205-♦-◆-G0 ④	J	350	OD9-205-♦-◆-TB450G0 ④	K2	400	OD9-205-♦-◆-JF65G0 ④	K3
250	230	PB9-580-EI-♦-◆-G0	~		Refer to Factory	~		Refer to Factory	~
	460	PC9-305-♦-◆-G0 ④	J2	600	PC9-305-♦-◆-TB600G0 ④	K2	600	PC9-305-♦-◆-JF66G0 ④	K2
	575	PD9-265-♦-◆-G0 ④	J	450	PD9-265-♦-◆-TB450G0 ④	K2	400	PD9-265-♦-◆-JF65G0 ④	K2
300	230	QB9-750-EI-♦-◆-G0	~		Refer to Factory	~		Refer to Factory	~
	460	QC9-370-♦-◆-G0 ④	J2	700	QC9-370-♦-◆-TB700G0 ④	K2	600	QC9-370-♦-◆-JF66G0 ④	K2
	575	QD9-305-♦-◆-G0 ④	J2	600	QD9-305-♦-◆-TB600G0 ④	K2	600	QD9-305-♦-◆-JF66G0 ④	K2
350	230	Refer to Factory	~		Refer to Factory	~		Refer to Factory	~
	460	RC9-400-EI-♦-◆-G0	J2	800	RC9-400-EI-♦-◆-TB800G0	RF	800	RC9-400-EI-♦-◆-JF67G0	~
	575	RD9-370-♦-◆-G0 ④	J2	600	RD9-370-♦-◆-TB600G0 ④	K2	600	RD9-370-♦-◆-JF66G0 ④	K2
400	230	Refer to Factory	~		Refer to Factory	~		Refer to Factory	~
	460	SC9-460-EI-♦-◆-G0	~	1000	SC9-460-EI-♦-◆-TB1000G0	~	800	SC9-460-EI-♦-◆-JF67G0	~
	575	SD9-400-EI-♦-◆-G0	J2	700	SD9-400-EI-♦-◆-TB700G0	K2	600	SD9-400-EI-♦-◆-JF66G0	~
450	230	Refer to Factory	~		Refer to Factory	~		Refer to Factory	~
	460	TC9-580-EI-♦-◆-G0	~		Refer to Factory	~			~
	575	TD9-460-EI-♦-◆-G0	~	800	TD9-460-EI-♦-◆-TB800G0	~			~
500	460	UC9-580-EI-♦-◆-G0	~		Refer to Factory	~			~
	575	UD9-460-EI-♦-◆-G0	~	900	Refer to Factory	~			~
600	460	UC9-750-EI-♦-◆-G0	~		Refer to Factory	~			~
	575	UD9-580-EI-♦-◆-G0	~			~		~	

Reduced Voltage Starters

Larger sizes available. Contact your Sprecher + Schuh representative.

NOTE: Catalog numbers and enclosure dimensions reflect contactors with AC coils. For DC coils, select Coil Code from the DC Coil Code table on page C104 and follow the instructions for modifying catalog numbers.

Ordering Instructions

Specify Catalog Number	
Replace (*) with Coil Code	See page C104 See pages C105-C106 See pages C107-C111
Replace (◆) with O/L Relay	
Factory Modifications available	

- ① Dimensional information starts on page C122.
- ② For Non-fusible Disconnect applications, replace the "JF" characters with "JU". Example: CAATNC9-205-EI-♦-◆-JF65G0 becomes CAATNC9-205-EI-♦-◆-JU65G0.
- ③ Fuse clips sized for use with "J"-type fuses up to 600A. Power fuses not supplied.
- ④ Other enclosures available. Contact your Sprecher + Schuh Representative.
- ⑤ A Red and Yellow Handle may be selected instead of the standard Gray and Black handle. Change "JF" to "LF" in catalog number.
- ⑥ CAT9-116...CAT9-370 starters are available with "EI" option for PLC interface. Change catalog number to include "-EI". For example: CAATND9-190-♦-◆-G0 becomes CAATND9-190-EI-♦-◆-G0.

Part Winding (Two Step)

Maximum Horsepower Three Phase				Type 1 General Purpose	D I M Type 12 [Type 3R Ⓣ] Industrial Dusttight	D I M Type 4 Watertight	D I M Type 4X Watertight Corrosion Resist Non-metallic	D I M
200V	230V	460V	575V	Catalog No.	① Catalog No.	① Catalog No.	① Catalog No.	①
				CAPWT	CAPWT	CAPWT	CAPWT	
10	15	30	30	7-30-*◆-G0	M 7-30-*◆-D0	M 7-30-*◆-W0	M 7-30-*◆-C0	U1
15	~	40	40	7-37-*◆-G0	M 7-37-*◆-D0	M 7-37-*◆-W0	M 7-37-*◆-C0	U1
20	20	50	50	7-43-*◆-G0	M 7-43-*◆-D0	M 7-43-*◆-W0	M 7-43-*◆-C0	U1
25	25	60	60	7-55-*◆-G0	M 7-55-*◆-D0	M 7-55-*◆-W0	M 7-55-*◆-C0	U1
25	30	60	75	7-60-*◆-G0	C 7-60-*◆-D0	O 7-60-*◆-W0	O 7-60-*◆-C0	V1
30	40	75	100	7-72-*◆-G0	C 7-72-*◆-D0	O 7-72-*◆-W0	O 7-72-*◆-C0	V1
40	50	100	125	7-85-*◆-G0	C 7-85-*◆-D0	O 7-85-*◆-W0	O 7-85-*◆-C0	V1
50	50	100	150	7-97-*◆-G0	C 7-97-*◆-D0	O 7-97-*◆-W0	O 7-97-*◆-C0	V1
60	60	100	150	9-116-*◆-G0 Ⓣ	E2 9-116-*◆-D0 Ⓣ	R2 9-116-*◆-W0 Ⓣ	R2 9-116-*◆-C0 Ⓣ	W2
60	75	150	200	9-146-*◆-G0 Ⓣ	G 9-146-*◆-D0 Ⓣ	T 9-146-*◆-W0 Ⓣ	T 9-146-*◆-C0 Ⓣ	A2
75	75	200	200	9-190-*◆-G0 Ⓣ	H 9-190-*◆-D0 Ⓣ	H 9-190-*◆-W0 Ⓣ	H 9-190-*◆-C0 Ⓣ	Y1
75	100	200	300	9-205-*◆-G0 Ⓣ	H 9-205-*◆-D0 Ⓣ	H 9-205-*◆-W0 Ⓣ	H 9-205-*◆-C0 Ⓣ	Y1
100	150	300	350	9-265-*◆-G0 Ⓣ	J 9-265-*◆-D0 Ⓣ	J 9-265-*◆-W0 Ⓣ	J 9-265-*◆-C0 Ⓣ	Z1
150	200	350	450	9-305-*◆-G0 Ⓣ	J 9-305-*◆-D0 Ⓣ	J 9-305-*◆-W0 Ⓣ	J 9-305-*◆-C0 Ⓣ	Z1

Larger sizes available. Contact your Sprecher + Schuh representative.

NOTE: Catalog numbers and enclosure dimensions reflect contactors with AC coils. For DC coils, select Coil Code from the DC Coil Code table on page C104 and follow the instructions for modifying catalog numbers.

Combination Part Winding Starter Options Chart Ⓣ

Circuit Breaker or Disconnect Switch	Enclosure Type	Options					
		7-30	7-37 7-43 7-55	7-60 7-72 7-85 7-97	9-116 (-EI) 9-146 (-EI)	9-190(-EI) 9-205(-EI) 9-265(-EI)	9-305(-EI)
Thermal Magnetic Circuit Breaker	Type 1						
	Type 12/3R/4/4X						
Non Fusible Disconnect	Type 1						
	Type 12/3R/4/4X						
Fusible Disconnect - 30 Amp	Type 1						
	Type 12/3R/4/4X						
Fusible Disconnect - 60 Amp	Type 1						
	Type 12/3R/4/4X						
Fusible Disconnect - 100 Amp	Type 1						
	Type 12/3R/4/4X						
Fusible Disconnect - 200 Amp	Type 1						
	Type 12/3R/4/4X						
Fusible Disconnect - 400 Amp	Type 1						
	Type 12/3R/4/4X						
Fusible Disconnect - 600 Amp	Type 1						
	Type 12/3R/4/4X						

Ordering Instructions

Specify Catalog Number	
Replace (*) with Coil Code	See page C104
Multiply Motor FLA by 50%,	
Replace (◆) with O/L Relay	See pages C105-C106
Factory Modifications available	See pages C107-C111

- ① Dimensional information starts on page C122.
- ② For Type 3R outdoor applications, replace "D" in catalog number with an "R". Price remains the same, dimensions may change. Example: CAPWT7-30-*◆-D0 becomes CAPWT7-30-*◆-R0.
- ③ Refer to pages C4-C5 for information on modifying standard Part Winding catalog number to combination type or contact Sprecher + Schuh Technical Support.
- ④ CAT9-116...CAT9-370 starters are available with "EI" option for PLC interface. Change catalog number to include "-EI". For example: CAATND9-190-*◆-G0 becomes CAATND9-190-EI-*◆-G0.

Wye Delta (Open Transition, 3-Contactor ⓐ)

Maximum Horsepower Three Phase				Type 1 General Purpose	D I M	Type 12 [Type 3R ⓐ] Industrial Dusttight	D I M	Type 4 Watertight	D I M	Type 4X Watertight Corrosion Resistant Non-metallic	D I M
200V	230V	460V	575V	Catalog No.	①	Catalog No.	①	Catalog No.	①	Catalog No.	①
				CAYT		CAYT		CAYT		CAYT	
10	15	30	30	7-30-*◆-GO	C	7-30-*◆-DO	O	7-30-*◆-WO	O	7-30-*◆-CO	V1
15	20	40	40	7-37-*◆-GO	C	7-37-*◆-DO	O	7-37-*◆-WO	O	7-37-*◆-CO	V1
20	25	50	50	7-43-*◆-GO	C	7-43-*◆-DO	O	7-43-*◆-WO	O	7-43-*◆-CO	V1
25	30	60	60	7-55-*◆-GO	C	7-55-*◆-DO	O	7-55-*◆-WO	O	7-55-*◆-CO	V1
30	40	75	75	7-60-*◆-GO	D	7-60-*◆-DO	Q	7-60-*◆-WO	Q	7-60-*◆-CO	W1
40	50	100	100	7-72-*◆-GO	F	7-72-*◆-DO	T	7-72-*◆-WO	T	7-72-*◆-CO	X1
50	60	125	125	7-85-*◆-GO	F	7-85-*◆-DO	T	7-85-*◆-WO	T	7-85-*◆-CO	X1
60	60	150	150	9-116-*◆-GO	G	9-116-*◆-DO	T	9-116-*◆-WO	T	9-116-*◆-CO	A2
75	75	150	200	9-146-*◆-GO	G	9-146-*◆-DO	T	9-146-*◆-WO	T	9-146-*◆-CO	A2
75	100	200	250	9-190-*◆-GO	H	9-190-*◆-DO	H	9-190-*◆-WO	H	9-190-*◆-CO	Y1
100	125	250	300	9-205-*◆-GO	I	9-205-*◆-DO	I	9-205-*◆-WO	J	9-205-*◆-CO	Z1
150	150	350	450	9-265-*◆-GO	J	9-265-*◆-DO	J	9-265-*◆-WO	J	9-265-*◆-CO	Z1
150	200	450	500	9-305-*◆-GO	J	9-305-*◆-DO	J	9-305-*◆-WO	J	9-305-*◆-CO	Z1
200	250	500	600	9-370-*◆-GO	J	9-370-*◆-DO	J	9-370-*◆-WO	J	9-370-*◆-CO	Z1
250	250	600	700	9-400-EI-*◆-GO	~	9-400-EI-*◆-DO	~	9-400-EI-*◆-WO	~	9-400-EI-*◆-CO	~
300	350	700	800	9-460-EI-*◆-GO	~	9-460-EI-*◆-DO	~	9-460-EI-*◆-WO	~	9-460-EI-*◆-CO	~
350	450	800	1000	9-580-EI-*◆-GO	~	9-580-EI-*◆-DO	~	9-580-EI-*◆-WO	~	9-580-EI-*◆-CO	~
450	500	1000	1250	9-750-EI-*◆-GO	~	9-750-EI-*◆-DO	~	9-750-EI-*◆-WO	~	9-750-EI-*◆-CO	~
600	700	1250	1750	9-860-EI-*◆-GO	~	9-860-EI-*◆-DO	~	9-860-EI-*◆-WO	~	9-860-EI-*◆-CO	~
600	700	1500	1750	9-1060-EI-*◆-GO	~	9-1060-EI-*◆-DO	~	9-1060-EI-*◆-WO	~	9-1060-EI-*◆-CO	~

Larger sizes available. Contact your Sprecher + Schuh representative.

Reduced Voltage Starters

Combination Wye Delta Starter Options Chart ⓐ

Circuit Breaker or Disconnect Switch	Enclosure Type	7-30	7-37 7-43 7-55	7-60 7-72 7-85	9-116 (-EI) 9-146 (-EI)	9-190(-EI) 9-205(-EI) 9-265(-EI)	9-305(-EI) 9-370(-EI) 9-400-EI	9-580-EI 9-750-EI 9-860-EI 9-1060-EI
		Thermal Magnetic Circuit Breaker	Type 1 Type 12/3R/4/4X					
Non Fusible Disconnect	Type 1 Type 12/3R/4/4X							
Fusible Disconnect - 30 Amp	Type 1 Type 12/3R/4/4X							
Fusible Disconnect - 60 Amp	Type 1 Type 12/3R/4/4X							
Fusible Disconnect - 100 Amp	Type 1 Type 12/3R/4/4X							
Fusible Disconnect - 200 Amp	Type 1 Type 12/3R/4/4X							
Fusible Disconnect - 400 Amp	Type 1 Type 12/3R/4/4X							
Fusible Disconnect - 600 Amp	Type 1 Type 12/3R/4/4X							

Ordering Instructions

Specify Catalog Number	
Replace (*) with Coil Code	See page C104
Replace (◆) with O/L Relay	See pages C105-C106
Factory Modifications available	See pages C107-C111

- ① Dimensional information starts on page C122.
- ② For Type 3R outdoor applications, replace "D" in catalog number with an "R". Dimensions may change. For example number CAYT7-30-*◆-DO becomes CAYT7-30-*◆-RO.
- ③ Refer to pages C4-C5 for information on modifying standard Wye Delta catalog number to combination type or contact Sprecher + Schuh Technical Support.
- ④ For closed transition Wye Delta applications, please contact factory.

Pump Controllers

Pump control panels for outdoor irrigation and oil well applications

C
Simplex & Duplex Pump Panels



Sprecher + Schuh pump control panels are specifically designed to meet Combination starter requirements in demanding outdoor environmental conditions. Typical applications include irrigation and waste water treatment as well as oil well and agricultural applications.

Pump Controllers from Sprecher + Schuh offer through-the-door operators and rugged Type 3R rain-proof metal or Type 4X non-metallic enclosures. These enclosures in some cases are somewhat smaller than previous models but still with adequate room to mount a mechanical timer and other customer supplied controls.

Three models of Pump Controllers

- **Thermal-magnetic circuit breakers (MCCB)** instead of a motor circuit protector (MCP) to comply with short-circuit requirements from UL and NEC.
- **Heavy duty fusible or non-fusible L11 disconnect switches** provide improved short-circuit protection when used with J fuses.
- **Self-protected Combination Controllers (Type E)** KTA7 models which offer superior fuseless short-circuit protection in a smaller more economical package (See page F111).

Pump panels feature our CA7 and CA9 line of contactors which are UL Listed and sized to match all the available HP sizes of motors. Alternately, we can provide NEMA Sized (CAN7) contactors, which comply with all requirements by UL and are labeled with the applicable NEMA (00, 0, 1, 2, or 3) size in our pump panels. Our MCCB models and the L11 models utilize the CEP7 solid state overload relay providing state-of-the-art overload and single-phase protection. See Section B in this catalog for a full description of these excellent motor protection relays.



Our KTA7 model utilizes the high speed current limiting capabilities providing short-circuit protection, branch-circuit disconnect, and overload protection in one compact device. See Section F in this catalog for application details for these Type E Combos.

Standard or Customized Features

Standard pump controllers are equipped with START pushbutton and H-O-A selector switch. The entire assembly is mounted in an outdoor enclosure with provision for mounting on a pole or a wall and top conduit provisions. Oversized enclosures can be provided for each of the pump controllers to accommodate extra equipment. Our factory modification section lists many of the options that are commonly requested. A customized pump controller quotation including door-in-door (dead-front) models, reduced voltage models and models with customized control diagrams can be provided on demand by contacting your Sprecher + Schuh representative.



Series CAPT7 and CAPT9 with Thermal-Magnetic Circuit Breaker

Maximum Horsepower Three Phase			MCCB Amps	Type 3R Rainproof Metal	DIM	Type 4X Watertight Corrosion Resistant Non-Metallic	DIM
230V	460V	575V		Catalog No.		Catalog No.	
2	5	~	15	7-9-*◆-TB15R0	R2	7-9-*◆-TB15C0	R/F
2	5	5	15	7-9-*◆-TBH15R0	R2	7-9-*◆-TBH15C0	R/F
~	~	7.5	20	7-9-*◆-TBH20R0	R2	7-9-*◆-TBH20C0	R/F
3	7.5	~	20	7-12-*◆-TB20R0	R2	7-12-*◆-TB20C0	R/F
3	7.5	10	20	7-12-*◆-TBH20R0	R2	7-12-*◆-TBH20C0	R/F
5	10	~	30	7-16-*◆-TB30R0	R2	7-16-*◆-TB30C0	R/F
~	~	15	35	7-23-*◆-TBH35R0	R2	7-23-*◆-TBH35C0	R/F
7.5	15	~	40	7-23-*◆-TB40R0	R2	7-23-*◆-TB40C0	R/F
10	20	25	50	7-30-*◆-TB50R0	R2	7-30-*◆-TB50C0	R/F
10	20	25	50	7-30-*◆-TBH50R0	R2	7-30-*◆-TBH50C0	R/F
~	25	30	60	7-37-*◆-TB60R0	R2	7-37-*◆-TB60C0	R/F
~	25	30	60	7-37-*◆-TBH60R0	R2	7-37-*◆-TBH60C0	R/F
~	30	~	70	7-43-*◆-TB70R0	R2	7-43-*◆-TB70C0	R/F
15	~	~	80	7-43-*◆-TB80R0	R2	7-43-*◆-TB80C0	R/F
20	40	40	80	7-55-*◆-TB80R0	R2	7-55-*◆-TB80C0	R/F
20	40	40	80	7-55-*◆-TBH80R0	R2	7-55-*◆-TBH80C0	R/F
~	~	40	80	7-60-*◆-TB80R0	R2	7-60-*◆-TB80C0	R/F
~	~	40	80	7-60-*◆-TBH80R0	R2	7-60-*◆-TBH80C0	R/F
20	40	50	100	7-60-*◆-TB100R0	R2	7-60-*◆-TB100C0	R/F
20	40	50	100	7-60-*◆-TBH100R0	R2	7-60-*◆-TBH100C0	R/F
25	50	60	125	7-72-*◆-TB125R0	R2	7-72-*◆-TB125C0	R/F
25	50	60	125	7-72-*◆-TBH125R0	R2	7-72-*◆-TBH125C0	R/F
30	60	~	125	7-85-*◆-TB125R0	R2	7-85-*◆-TB125C0	R/F
~	~	75	150	7-97-*◆-TB150R0	R2	7-97-*◆-TB150C0	R/F
~	~	75	150	7-97-*◆-TBH150R0	R2	7-97-*◆-TBH150C0	R/F
~	75	~	175	7-97-*◆-TB175R0	R2	7-97-*◆-TB175C0	R/F
~	75	~	175	9-116-*◆-TB175R0	T	9-116-*◆-TB175C0	R/F
40	~	100	200	9-116-*◆-TB200R0	T	9-116-*◆-TB200C0	R/F
~	100	125	225	9-146-*◆-TB225R0	T	9-146-*◆-TB225C0	R/F
50	~	~	250	9-146-*◆-TB250R0	T	9-146-*◆-TB250C0	R/F
60	125	150	300	9-190-*◆-TB300R0	T	9-190-*◆-TB300C0	R/F
75	150	200	350	9-205-*◆-TB350R0	I	9-205-*◆-TB350C0	R/F
~	175	~	400	9-265-*◆-TB400R0	I	9-265-*◆-TB400C0	R/F
100	200	250	450	9-265-*◆-TB450R0	I	9-265-*◆-TB450C0	R/F
~	~	~	500	9-305-*◆-TB500R0	I	9-305-*◆-TB500C0	R/F
125	250	300	600	9-305-*◆-TB600R0	I	9-305-*◆-TB600C0	R/F
~	~	350	600	9-370-*◆-TB600R0	I	9-370-*◆-TB600C0	R/F
150	300	~	700	9-370-*◆-TB700R0	I	9-370-*◆-TB700C0	R/F
150	~	400	700	9-400-EI-*◆-TB700R0	J	9-400-EI-*◆-TB700C0	R/F
~	350	~	800	9-400-EI-*◆-TB800R0	J	9-400-EI-*◆-TB800C0	R/F
~	~	~	800	9-460-EI-*◆-TB800R0	J	9-460-EI-*◆-TB800C0	R/F
200	400	500	1000	9-460-EI-*◆-TB1000R0	J	9-460-EI-*◆-TB1000C0	R/F
~	~	600	1000	9-580-EI-*◆-TB1000R0	R/F	9-580-EI-*◆-TB1000C0	R/F
250	500	~	1200	9-580-EI-*◆-TB1200R0	R/F	9-580-EI-*◆-TB1200C0	R/F

Larger sizes available. Contact your Sprecher + Schuh representative.

Ordering Instructions

Specify Catalog Number	
Replace (*) with Coil Code	See page C104
Replace (◆) with O/L Relay	See pages C105-C106
Factory Modifications available	See pages C107-C111

Pump Panel with Circuit Breaker includes:

- Contactor (with AC coil)
- Overload relay protection
- Thermal magnetic circuit breaker
- "START" momentary pushbutton
- "H-O-A" selector switch
- At minimum, 6"x10" extra back pan space
- UL type rated enclosure



CAPT7-23...

R/F - Experience has shown that applications using non-metallic enclosures often require customized pump panels (i.e. Door-in-Door or unique control circuits). Contact your Sprecher + Schuh representative for a customized price.

NOTE: Catalog Numbers, list Prices and enclosure dimensions reflect contactors with AC coils. For DC coils, select Coil Code from the DC Coil Code table on page C104 and follow the instructions for modifying Catalog Numbers.

- ① Dimensional information starts on page C122.
- ② Applicable to 600Y/347V only.
- ③ The short circuit and kAIC is relegated to the contactor's 10kA. Contact your Sprecher + Schuh representative for a higher kAIC.
- ④ CAT9-116...CAT9-370 starters are available with "EI" option for PLC interface. Change catalog number to include "-EI". Example: CAPT9-116-*◆-TB175R0 becomes CAPT9-116-EI-*◆-TB175R0.

Series CAPT7 and CAPT9 with Fusible Disconnect (J-Type) ②③

Maximum Horsepower Three Phase			Fuse Clips	Type 3R Rainproof Metal	D I M ①	Type 4X Watertight Corrosion Resistant Non-metallic	D I M ①
230V	460V	575V		Catalog No.		Catalog No.	
				CAPT		CAPT	
2	5	7.5	30	7-9-*◆-JF61R0	R2	7-9-*◆-JF61C0	R/F
3	7.5	10	30	7-12-*◆-JF61R0	R2	7-12-*◆-JF61C0	R/F
5	10	15	30	7-16-*◆-JF61R0	R2	7-16-*◆-JF61C0	R/F
~	~	~	30	7-23-*◆-JF61R0	R2	7-23-*◆-JF61C0	R/F
7.5	15	15	60	7-23-*◆-JF62R0	R2	7-23-*◆-JF62C0	R/F
10	20	25	60	7-30-*◆-JF62R0	R2	7-30-*◆-JF62C0	R/F
10	25	30	60	7-37-*◆-JF62R0	R2	7-37-*◆-JF62C0	R/F
~	30	30	60	7-43-*◆-JF62R0	R2	7-43-*◆-JF62C0	R/F
15	~	~	100	7-43-*◆-JF63R0	R2	7-43-*◆-JF63C0	R/F
~	~	40	60	7-55-*◆-JF62R0	R2	7-55-*◆-JF62C0	R/F
20	40	~	100	7-55-*◆-JF63R0	R2	7-55-*◆-JF63C0	R/F
~	~	40	60	7-60-*◆-JF62R0	R2	7-60-*◆-JF62C0	R/F
20	40	50	100	7-60-*◆-JF63R0	R2	7-60-*◆-JF63C0	R/F
25	50	60	100	7-72-*◆-JF63R0	R2	7-72-*◆-JF63C0	R/F
~	~	60	100	7-85-*◆-JF63R0	R2	7-85-*◆-JF63C0	R/F
30	60	~	200	7-85-*◆-JF64R0	H	7-85-*◆-JF64C0	R/F
30	75	75	200	7-97-*◆-JF64R0	H	7-97-*◆-JF64C0	R/F
40	75	100	200	9-116-*◆-JF64R0 ④	H	9-116-*◆-JF64C0 ④	R/F
50	100	125	200	9-146-*◆-JF64R0 ④	H	9-146-*◆-JF64C0 ④	R/F
60	125	150	400	9-190-*◆-JF65R0 ④	J	9-190-*◆-JF65C0 ④	R/F
75	150	200	400	9-205-*◆-JF65R0 ④	J	9-205-*◆-JF65C0 ④	R/F
100	200	250	400	9-265-*◆-JF65R0 ④	J	9-265-*◆-JF65C0 ④	R/F
125	250	300	600	9-305-*◆-JF66R0 ④	R/F	9-305-*◆-JF66C0 ④	R/F
150	300	350	600	9-370-*◆-JF66R0 ④	R/F	9-370-*◆-JF66C0 ④	R/F
150	~	400	600	9-400-EI-*◆-JF66R0	R/F	9-400-EI-*◆-JF66C0	R/F
~	350	~	800	9-400-EI-*◆-JF67R0	R/F	9-400-EI-*◆-JF67C0	R/F
200	400	500	800	9-460-EI-*◆-JF67R0	R/F	9-460-EI-*◆-JF67C0	R/F

Larger sizes available. Contact your Sprecher + Schuh representative.

NOTE: Catalog Numbers, list Prices and enclosure dimensions reflect contactors with AC coils. For DC coils, select Coil Code from the DC Coil Code table on page C104 and follow the instructions for modifying Catalog Numbers.

Pump Panel with Disconnect Switch includes:

- Contactor (with AC coil)
- Overload relay protection
- J-type fusible disconnect switch (excluding line fuses)
- "START" momentary pushbutton
- "H-O-A" selector switch
- At minimum, 6"x10" extra back pan space
- UL type rated enclosure

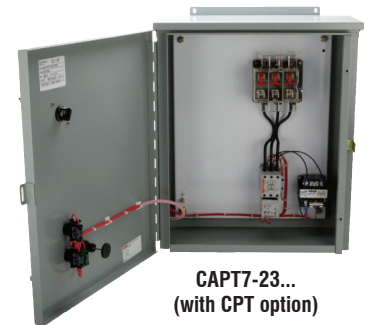

CAPT7-23... (with CPT option)

R/F - Experience has shown that applications using non-metallic enclosures often require customized pump panels (i.e. Door-in-Door or unique control circuit). Contact your Sprecher + Schuh representative for a customized price.

Ordering Instructions

Specify Catalog Number	
Replace (*) with Coil Code	See page C104
Replace (◆) with O/L Relay	See pages C105-C106
Factory Modifications available	See pages C107-C111

- ① Dimensional information starts on page C122.
- ② Fusible combo starters use the L11 Disconnect. Fuse clips accept "J" type fuses. Power fuses not supplied.
- ③ A Red and Yellow Handle may be selected instead of the standard Gray and Black handle. Change "JF" to "LF" in catalog number.
- ④ CAT9-116...CAT9-370 starters are available with "EI" option for PLC interface. Change catalog number to include "-EI". Example: CAPT9-116-*◆-JF64R0 becomes CAPT9-116-EI-*◆-JF64R0.

Series CAPTN7 with Thermal-Magnetic Circuit Breaker

NEMA Size	Maximum Horsepower Three Phase			MCCB Amps	Type 3R Rainproof Metal	DIM	Type 4X Watertight Corrosion Resistant Non-Metallic	DIM
	230V	460V	575V		Catalog No.		① Catalog No.	
00	1-1/2	2	2 Ⓢ	15	7-12-*◆-TB15R0	R2	7-12-*◆-TB15C0	R/F
	1-1/2	2	2	15	7-12-*◆-TBH15R0	R2	7-12-*◆-TBH15C0	R/F
0	2	5	5 Ⓢ	15	7-16-*◆-TB15R0	R2	7-16-*◆-TB15C0	R/F
	2	5	5	15	7-16-*◆-TBH15R0	R2	7-16-*◆-TBH15C0	R/F
	3	~	~	20	7-16-*◆-TB20R0	R2	7-16-*◆-TB20C0	R/F
	3	~	~	20	7-16-*◆-TBH20R0	R2	7-16-*◆-TBH20C0	R/F
1	7-1/2	~	~	40	7-37-*◆-TB40R0	R2	7-37-*◆-TB40C0	R/F
	~	10	~	30	7-37-*◆-TB30R0	R2	7-37-*◆-TB30C0	R/F
	~	~	10 Ⓢ	20	7-37-*◆-TB20R0	R2	7-37-*◆-TB20C0	R/F
	~	~	10	20	7-37-*◆-TBH20R0	R2	7-37-*◆-TBH20C0	R/F
2	~	~	25 Ⓢ	50	7-43-*◆-TB50R0	R2	7-43-*◆-TB50C0	R/F
	~	~	25	50	7-43-*◆-TBH50R0	R2	7-43-*◆-TBH50C0	R/F
	~	25	~	60	7-43-*◆-TB60R0	R2	7-43-*◆-TB60C0	R/F
	15	~	~	80	7-43-*◆-TB80R0	R2	7-43-*◆-TB80C0	R/F
3	20	40	50 Ⓢ	100	7-85-*◆-TB100R0	R2	7-85-*◆-TB100C0	R/F
	20	40	50	100	7-85-*◆-TBH100R0	R2	7-85-*◆-TBH100C0	R/F
	30	50	~	125	7-85-*◆-TB125R0	R2	7-85-*◆-TB125C0	R/F

Pump Panel with NEMA label includes:

- NEMA labeled contactor (with AC coil)
- Overload relay protection
- Appropriate disconnect means thermal magnetic circuit breaker) or J-type fusible disconnect switch (excluding line fuses)
- "START" momentary push-button
- "H-O-A" selector switch
- At minimum, 6"x10" extra back pan space
- UL type rated enclosure

R/F - Experience has shown that applications using non-metallic enclosures often require customized pump panels (i.e. Door-in-Door or unique control circuit). Contact your Sprecher + Schuh representative for a customized price.

Series CAPTN7 with Fusible Disconnect (J-Type) ②③

NEMA Size	Maximum Horsepower Three Phase			Fuse Clips	Type 3R Industrial Dusttight	DIM	Type 4X Watertight Corrosion Resistant Non-Metallic	DIM
	230V	460V	575V		Catalog No.		① Catalog No.	
					CAPTN		CAPTN	
00	1-1/2	2	2	30	7-12-*◆-JF61R0	R2	7-12-*◆-JF61C0	R/F
0	3	5	5	30	7-16-*◆-JF61R0	R2	7-16-*◆-JF61C0	R/F
1	7-1/2	~	~	60	7-37-*◆-JF62R0	R2	7-37-*◆-JF62C0	R/F
	~	10	10	30	7-37-*◆-JF61R0	R2	7-37-*◆-JF61C0	R/F
2	15	~	~	100	7-43-*◆-JF63R0	R2	7-43-*◆-JF63C0	R/F
	~	25	25	60	7-43-*◆-JF62R0	R2	7-43-*◆-JF62C0	R/F
3	30	~	~	200	7-85-*◆-JF64R0	H	7-85-*◆-JF64C0	R/F
	~	50	50	100	7-85-*◆-JF63R0	H	7-85-*◆-JF63C0	R/F

NOTE: Catalog Numbers, list Prices and enclosure dimensions reflect contactors with AC coils. For DC coils, select Coil Code from the DC Coil Code table on page C104 and follow the instructions for modifying Catalog Numbers.

Ordering Instructions

Specify Catalog Number	
Replace (*) with Coil Code	See page C104
Replace (◆) with O/L Relay	See pages C105-C106
Factory Modifications available	See pages C107-C111

- ① Dimensional information starts on page C122.
- ② Fusible combo starters use the L11 Disconnect. Fuse clips accept "J" type fuses. Power fuses not supplied.
- ③ A Red and Yellow Handle may be selected instead of the standard Gray and Black handle. Change "JF" to "LF" in catalog number.
- ④ Applicable to 600Y/347V only.

Duplex Pump Controllers

Sprecher + Schuh duplex pump control panels are specifically designed to meet multi-starter combination requirements as defined in demanding outdoor environmental conditions.

Duplex pump controllers are typically designed for two specific requirements: duplexing and alternation.



Duplexing provides capacity for above normal demand or system peaking by allowing both motors to run simultaneously. It also provides standby capacity if one unit fails. Typically multiple pressure or float switches are required to provide electrical signals to the controller.

Alternation provides for equal wear on the two machines being controlled by reversing the lead and lag role of the specific motors. Alternation occurs at any time the two motors come to rest.

Duplex Pump Controllers from Sprecher + Schuh offer through-the-door operators and rugged Type 3R rain-proof metal or Type 4X non-metallic enclosures.



contactors which comply with all requirements by UL and are labeled with the applicable NEMA (00, 0, 1, 2, or 3) size in our pump panels.

Our MCCB models and the L11 models utilize the CEP7 solid state overload relay providing state-of-the-art overload and single-phase protection. See Section B in this catalog for a full description of these excellent motor protection relays.

Our KTA7 model utilizes the high speed current limiting capabilities providing short-circuit protection, branch-circuit disconnect, and overload protection in one compact device. These Type E panels are smaller than classic models and therefore represent an economical solution to duplexing. See Section F in this catalog for application details for these Type E Combos.

Experience has shown us that duplex pump panels often require customization to accommodate unique components and unique control schematic diagrams. In the following pages you will find a catalog number structure showing standard models with standard options to help guide your selection. We have also provided a check list which can be utilized to request a similar model except customized to meet your application by contacting your Sprecher + Schuh representative.

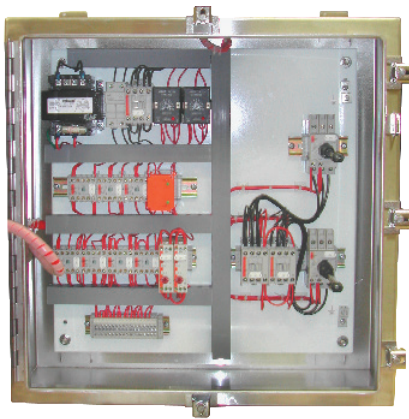

Three models of Duplex Controllers

- **Thermal-magnetic circuit breakers (MCCB)** instead of a motor circuit protector (MCP) to comply with new short-circuit requirements from UL and NEC.
- **Heavy duty fusible or non-fusible L11 disconnect switches** providing improved short-circuit protection when used with J fuses.
- **Self-protected Combination Controllers (Type E)** KTA7 models which offers superior fuseless short-circuit protection in a smaller more economical package (See page F111).

Custom Control Panels

Sprecher + Schuh custom control facility manufactures custom panels for almost any need, including this duplex control panel in a custom Type 4 stainless steel enclosure.

Duplex pump panels feature our CA7 and CA9 line of contactors, which are UL Listed and sized to match all the available HP sizes of motors. Alternately, we can provide NEMA Sized (CAN7)

Duplex Pump Panel Checklist	
Customer Name: _____	Location: _____
Project Name: _____	_____
Contact Person: _____	Phone No.: _____
Email: _____	Date: _____

G
Simplex & Duplex Pump Panels

Standard catalog number selected from the following pages: _____

with the exceptions noted below

Application Data: Motor HP: _____ Voltage: _____ Phase: _____ FLA _____

Disconnect? Yes No

If yes, type of disconnect: J-Type Fusible Non-Fusible Circuit breaker Type E combination controller

Starting Method: Across-the-line

Softstarter

Control Transformer: Yes No

If Yes, is there any extra VA capacity required other than what is provided as standard? _____ Extra VA required

Options: H-O-A

Pilot Light; Color _____ Function _____

Terminal Points; Qty _____

Phase Monitor

Hour Meter

Lightning Arrestor

Alternator

Number of float switches 1 2 3

Alarm Circuit Horn Light Type _____ Alarm Silence Button

Other _____ Custom Schematic (Must be attached)

Enclosure: Type 1 Type 12 Type 13 Type 3R Type 4

Type 4X If Type 4X, non-metallic 304 stainless steel 316 stainless steel

Door-in-door (dead front)

Special Features:

Series CADPT7 and CADPT9

Maximum Horsepower Three Phase			Type 3R Rainproof (Metal)	D I M	Type 4X Watertight Corrosion Resistant Non-metallic	D I M
230V	460V	575V	Catalog No.		Catalog No.	
			CADPT		CADPT	
2	5	7.5	7-9-*◆-R0	R/F	7-9-*◆-C0	R/F
3	7.5	10	7-12-*◆-R0	R/F	7-12-*◆-C0	R/F
5	10	15	7-16-*◆-R0	R/F	7-16-*◆-C0	R/F
7.5	15	15	7-23-*◆-R0	R/F	7-23-*◆-C0	R/F
10	20	25	7-30-*◆-R0	R/F	7-30-*◆-C0	R/F
10	25	30	7-37-*◆-R0	R/F	7-37-*◆-C0	R/F
15	30	30	7-43-*◆-R0	R/F	7-43-*◆-C0	R/F
20	40	40	7-55-*◆-R0	R/F	7-55-*◆-C0	R/F
20	40	50	7-60-*◆-R0	R/F	7-60-*◆-C0	R/F
25	50	60	7-72-*◆-R0	R/F	7-72-*◆-C0	R/F
30	60	60	7-85-*◆-R0	R/F	7-85-*◆-C0	R/F
30	75	75	7-97-*◆-R0	R/F	7-97-*◆-C0	R/F
40	75	100	9-116-*◆-R0 ①	R/F	9-116-*◆-C0 ①	R/F
50	100	125	9-146-*◆-R0 ①	R/F	9-146-*◆-C0 ①	R/F
60	125	150	9-190-*◆-R0 ①	R/F	9-190-*◆-C0 ①	R/F
75	150	200	9-205-*◆-R0 ①	R/F	9-205-*◆-C0 ①	R/F
100	200	250	9-265-*◆-R0 ①	R/F	9-265-*◆-C0 ①	R/F
125	250	300	9-305-*◆-R0 ①	R/F	9-305-*◆-C0 ①	R/F
150	300	350	9-370-*◆-R0 ①	R/F	9-370-*◆-C0 ①	R/F
150	350	400	9-400-EI-*◆-R0	R/F	9-400-EI-*◆-C0	R/F
200	400	500	9-460-EI-*◆-R0	R/F	9-460-EI-*◆-C0	R/F
250	500	600	9-580-EI-*◆-R0	R/F	9-580-EI-*◆-C0	R/F
300	600	700	9-750-EI-*◆-R0	R/F	9-750-EI-*◆-C0	R/F
400	800	1000	9-860-EI-*◆-R0	R/F	9-860-EI-*◆-C0	R/F
450	900	1150	9-1060-EI-*◆-R0	R/F	9-1060-EI-*◆-C0	R/F

Duplex Pump Controller includes:

- (2) Contactors (AC coil)
- (2) Overload relay protection
- (1) Electronic alternating relay
- (1) UL type rated enclosure
- Designed per alternation control diagram shown at bottom of page C119

R/F - Experience has shown that applications using non-metallic enclosures often require customized pump panels (i.e. Door-in-Door or unique control circuit). Contact your Sprecher + Schuh representative for a customized price.

Note: Catalog numbers, list prices and enclosure dimensions reflect contactors with AC coils. For DC coils, select Coil Code from the DC Coil Code table on page C104 and follow the instructions for modifying Catalog Numbers.

Ordering Instructions

Specify Catalog Number	
Replace (*) with Coil Code	See page C104
Replace (◆) with O/L Relay	See pages C105-C106
Factory Modifications available	See pages C107-C111

- ① CAT9-116...CAT9-370 starters are available with "EI" option for PLC interface. Change catalog number to include "-EI". Example: CADPT9-116-*◆-R0 becomes CADPT9-116-EI-*◆-R0.

Series CADPT7 and CADPT9 with Thermal-Magnetic Circuit Breaker

Maximum Horsepower Three Phase			MCCB Amps	Type 3R Rainproof (Metal)	D I M	Type 4X Watertight Corrosion Resistant Non-metallic	D I M
230V	460V	575V		Catalog Number		Catalog Number	
				CADPT		CADPT	
2	5	~	15	7-9-*◆-TB15RO	R/F	7-9-*◆-TB15CO	R/F
2	5	5	15	7-9-*◆-TBH15RO	R/F	7-9-*◆-TBH15CO	R/F
~	~	7.5	20	7-9-*◆-TBH20RO	R/F	7-9-*◆-TBH20CO	R/F
3	7.5	~	20	7-12-*◆-TB20RO	R/F	7-12-*◆-TB20CO	R/F
3	7.5	10	20	7-12-*◆-TBH20RO	R/F	7-12-*◆-TBH20CO	R/F
5	10	~	30	7-16-*◆-TB30RO	R/F	7-16-*◆-TB30CO	R/F
~	~	15	35	7-23-*◆-TBH35RO	R/F	7-23-*◆-TBH35CO	R/F
7.5	15	~	40	7-23-*◆-TB40RO	R/F	7-23-*◆-TB40CO	R/F
10	20	25 ①	50	7-30-*◆-TB50RO	R/F	7-30-*◆-TB50CO	R/F
10	20	25	50	7-30-*◆-TBH50RO	R/F	7-30-*◆-TBH50CO	R/F
10	25	30 ①	50	7-37-*◆-TB50RO	R/F	7-37-*◆-TB50CO	R/F
10	25	30	50	7-37-*◆-TBH50RO	R/F	7-37-*◆-TBH50CO	R/F
~	30	~	70	7-43-*◆-TB70RO	R/F	7-43-*◆-TB70CO	R/F
15	~	~	80	7-43-*◆-TB80RO	R/F	7-43-*◆-TB80CO	R/F
20	40	40 ①	80	7-55-*◆-TB80RO	R/F	7-55-*◆-TB80CO	R/F
20	40	40	80	7-55-*◆-TBH80RO	R/F	7-55-*◆-TBH80CO	R/F
~	~	40 ①	80	7-60-*◆-TB80RO	R/F	7-60-*◆-TB80CO	R/F
~	~	40	80	7-60-*◆-TBH80RO	R/F	7-60-*◆-TBH80CO	R/F
20	40	50 ①	100	7-60-*◆-TB100RO	R/F	7-60-*◆-TB100CO	R/F
20	40	50	100	7-60-*◆-TBH100RO	R/F	7-60-*◆-TBH100CO	R/F
25	50	60 ①	125	7-72-*◆-TB125RO	R/F	7-72-*◆-TB125CO	R/F
25	50	60	125	7-72-*◆-TBH125RO	R/F	7-72-*◆-TBH125CO	R/F
30	60	~	125	7-85-*◆-TB125RO	R/F	7-85-*◆-TB125CO	R/F
~	~	75 ①②	150	7-97-*◆-TB150RO	R/F	7-97-*◆-TB150CO	R/F
~	~	75 ②	150	7-97-*◆-TBH150RO	R/F	7-97-*◆-TBH150CO	R/F
~	75 ②	~	175	7-97-*◆-TB175RO	R/F	7-97-*◆-TB175CO	R/F
~	75	~	175	9-116-*◆-TB175RO ③	R/F	9-116-*◆-TB175CO ③	R/F
40	~	100 ②	200	9-116-*◆-TB200RO ③	R/F	9-116-*◆-TB200CO ③	R/F
~	100	125 ②	225	9-146-*◆-TB225RO ③	R/F	9-146-*◆-TB225CO ③	R/F
50	~	~	250	9-146-*◆-TB250RO ③	R/F	9-146-*◆-TB250CO ③	R/F
60	125	150	300	9-190-*◆-TB300RO ③	R/F	9-190-*◆-TB300CO ③	R/F
75	150	200	350	9-205-*◆-TB350RO ③	R/F	9-205-*◆-TB350CO ③	R/F
~	175	~	400	9-265-*◆-TB400RO ③	R/F	9-265-*◆-TB400CO ③	R/F
100	200	250	450	9-265-*◆-TB450RO ③	R/F	9-265-*◆-TB450CO ③	R/F
~	~	~	500	9-305-*◆-TB500RO ③	R/F	9-305-*◆-TB500CO ③	R/F
125	250	300	600	9-305-*◆-TB600RO ③	R/F	9-305-*◆-TB600CO ③	R/F
~	~	350	600	9-370-*◆-TB600RO ③	R/F	9-370-*◆-TB600CO ③	R/F
150	300	~	700	9-370-*◆-TB700RO ③	R/F	9-370-*◆-TB700CO ③	R/F
150	~	400	700	9-400-EI-*◆-TB700RO	R/F	9-400-EI-*◆-TB700CO	R/F
~	350	~	800	9-400-EI-*◆-TB800RO	R/F	9-400-EI-*◆-TB800CO	R/F
~	~	~	800	9-460-EI-*◆-TB800RO	R/F	9-460-EI-*◆-TB800CO	R/F
200	400	500	1000	9-460-EI-*◆-TB1000RO	R/F	9-460-EI-*◆-TB1000CO	R/F
~	~	600	1000	9-580-EI-*◆-TB1000RO	R/F	9-580-EI-*◆-TB1000CO	R/F
250	500	~	1200	9-580-EI-*◆-TB1200RO	R/F	9-580-EI-*◆-TB1200CO	R/F

Duplex Pump Controller with circuit breaker includes:

- (2) Contactors (AC coil)
- (2) Overload relay protection
- (2) Thermal magnetic circuit breakers
- (1) Electronic alternating relay
- (1) UL type rated enclosure
- Designed per alternation control diagram shown at bottom of page C119

R/F - Experience has shown that applications using non-metallic enclosures often require customized pump panels (i.e. Door-in-Door or unique control circuit). Contact your Sprecher + Schuh representative for a customized price.

Note: Catalog numbers, list prices and enclosure dimensions reflect contactors with AC coils. For DC coils, select Coil Code from the DC Coil Code table on page C104 and follow the instructions for modifying Catalog Numbers.

Ordering Instructions

Specify Catalog Number	
Replace (*) with Coil Code	See page C104
Replace (◆) with O/L Relay	See pages C105-C106
Factory Modifications available	See pages C107-C111

- ① Applicable to 600Y/347V only.
- ② The short circuit and kAIC is relegated to the contactor's 10kA. Contact your Sprecher + Schuh representative for a higher kAIC.
- ③ CAT9-116...CAT9-370 starters are available with "EI" option for PLC interface. Change catalog number to include "-EI". Example: CADPT9-116-*◆-TB175RO becomes CADPT9-116-EI-*◆-TB175RO.

C Simplex & Duplex Pump Panels

Series CADPT7 and CADPT9 with Fusible Disconnect (J-Type) ①②

Maximum Horsepower Three Phase				Fuse clip Amps	Type 3R Rainproof (Metal)	D I M	Type 4X Watertight Corrosion Resistant Non-metallic	D I M
200V	230V	460V	575V		Catalog Number		Catalog Number	
					CADPT		CADPT	
2	2	5	7.5	30	7-9-*-*♦-JF61RO	R/F	7-9-*-*♦-JF61CO	R/F
3	3	7.5	10	30	7-12-*-*♦-JF61RO	R/F	7-12-*-*♦-JF61CO	R/F
5	5	10	15	30	7-16-*-*♦-JF61RO	R/F	7-16-*-*♦-JF61CO	R/F
5	~	~	~	30	7-23-*-*♦-JF61RO	R/F	7-23-*-*♦-JF61CO	R/F
~	7.5	15	15	60	7-23-*-*♦-JF62RO	R/F	7-23-*-*♦-JF62CO	R/F
7.5	10	20	25	60	7-30-*-*♦-JF62RO	R/F	7-30-*-*♦-JF62CO	R/F
10	10	25	30	60	7-37-*-*♦-JF62RO	R/F	7-37-*-*♦-JF62CO	R/F
10	~	30	30	60	7-43-*-*♦-JF62RO	R/F	7-43-*-*♦-JF62CO	R/F
~	15	~	~	100	7-43-*-*♦-JF63RO	R/F	7-43-*-*♦-JF63CO	R/F
~	~	~	40	60	7-55-*-*♦-JF62RO	R/F	7-55-*-*♦-JF62CO	R/F
15	20	40	~	100	7-55-*-*♦-JF63RO	R/F	7-55-*-*♦-JF63CO	R/F
~	~	~	40	60	7-60-*-*♦-JF62RO	R/F	7-60-*-*♦-JF62CO	R/F
15	20	40	50	100	7-60-*-*♦-JF63RO	R/F	7-60-*-*♦-JF63CO	R/F
20	25	50	60	100	7-72-*-*♦-JF63RO	R/F	7-72-*-*♦-JF63CO	R/F
~	~	~	60	100	7-85-*-*♦-JF63RO	R/F	7-85-*-*♦-JF63CO	R/F
25	30	60	~	200	7-85-*-*♦-JF64RO	R/F	7-85-*-*♦-JF64CO	R/F
30	30	75	75	200	7-97-*-*♦-JF64RO	R/F	7-97-*-*♦-JF64CO	R/F
30	40	75	100	200	9-116-*-*♦-JF64RO ③	R/F	9-116-*-*♦-JF64CO ③	R/F
40	50	100	125	200	9-146-*-*♦-JF64RO ③	R/F	9-146-*-*♦-JF64CO ③	R/F
50	60	125	150	400	9-190-*-*♦-JF65RO ③	R/F	9-190-*-*♦-JF65CO ③	R/F
60	75	150	200	400	9-205-*-*♦-JF65RO ③	R/F	9-205-*-*♦-JF65CO ③	R/F
75	100	200	250	400	9-265-*-*♦-JF65RO ③	R/F	9-265-*-*♦-JF65CO ③	R/F
100	125	250	300	600	9-305-*-*♦-JF66RO ③	R/F	9-305-*-*♦-JF66CO ③	R/F
125	150	300	350	600	9-370-*-*♦-JF66RO ③	R/F	9-370-*-*♦-JF66CO ③	R/F
125	150	~	400	600	9-400-EI-*-*♦-JF66RO	R/F	9-400-EI-*-*♦-JF66CO	R/F
~	~	350	~	800	9-400-EI-*-*♦-JF67RO	R/F	9-400-EI-*-*♦-JF67CO	R/F
150	200	400	500	800	9-460-EI-*-*♦-JF67RO	R/F	9-460-EI-*-*♦-JF67CO	R/F

Duplex Pump Controller with disconnect switch includes:

- (2) Contactors (AC coil)
- (2) Overload relay protection
- (2) J-type fusible disconnect switch (excluding line fuses)
- (1) Electronic alternating relay
- (1) UL type rated enclosure
- Designed per alternation control diagram shown at bottom of page C119

Note: Catalog numbers, list prices and enclosure dimensions reflect contactors with AC coils. For DC coils, select Coil Code from the DC Coil Code table on page C104 and follow the instructions for modifying Catalog Numbers.

R/F - Experience has shown that applications requiring duplex pump panels often require customization. (i.e.: unique components and control circuits). Contact your Sprecher + Schuh representative for a customized price.

Ordering Instructions

Specify Catalog Number	
Replace (*) with Coil Code	See page C104
Replace (♦) with O/L Relay	See pages C105-C106
Factory Modifications available	See pages C107-C111

- ① Fusible combo starters use the L11 Disconnect. Fuse clips accept "J" type fuses. Power fuses not supplied.
- ② A Red and Yellow Handle may be selected instead of the standard Gray and Black handle. Change "JF" to "LF" in catalog number.
- ③ CAT9-116...CAT9-370 starters are available with "EI" option for PLC interface. Change catalog number to include "-EI". Example: CADPT9-116-*-*♦-JF64RO becomes CADPT9-116-EI-*-*♦-JF64RO.

Type E/F Combination Controllers

An alternative to the
Classic Combination
Starter

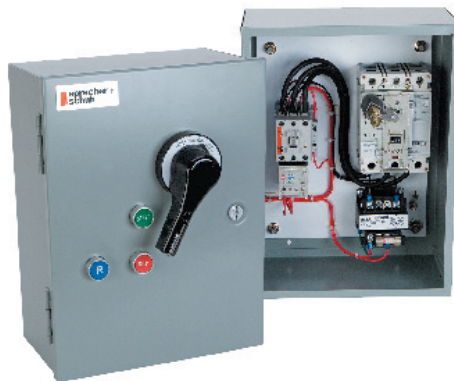

Classic Construction Type C
Thermal Magnetic MCCB
Combination Starter

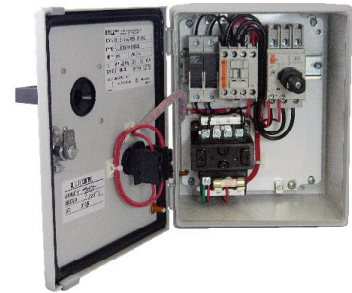

Construction Type E/F
E-Combo Self-Protected
Motor Controller

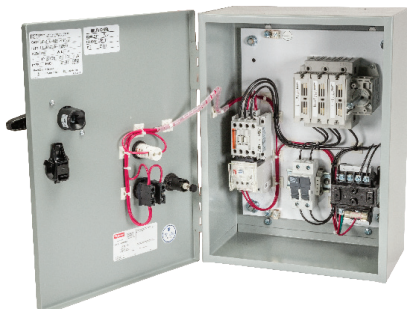

Classic Construction Type A
Fusible Combination Starter

The Classic Combo

Classic combination starters in Construction Type A use fusible L11 Disconnect switches. Construction Type C combos use UL489 Molded Case Circuit Breakers. Both are popular choices but Sprecher + Schuh's E-Combo line offers an alternative.

Advanced Alternative

Technology has advanced in the last two decades and UL, NEC, and CSA now recognize Self-Protected Combination Motor Controllers as providing a means of thru-the-door disconnect, short circuit protection, and overload protection in a single device (KTA7). Further, when KTA7 is combined with CA7 contactors for remote operation, the resulting assembly is a Construction Type E/F Combination Starter. Less components and a smaller enclosure means a functional equal to the Classic Combo at a reduced price.



The E-Combo Starter

Sprecher + Schuh's Ecombo and EcomboPlus starters are the compact alternative to larger and higher priced combination starters. E-Combos include:

- KTA7 "Type E/F" Self-protected Motor Controller with 1 N.O. front mount auxiliary contact
- CA7 or CAN7 Contactors (for remote operation)
- Terminal Adaptor for Type E Applications
- Power and Control Wiring
- Type 12/4 enclosure, dual rated - watertight, dusttight
- Gray/Black or Red/Yellow Type 4/4X/12; IP66 handle
- Factory installed pilot device options
- Higher SCCR ratings than MCCB combination versions
- All in a smaller NEMA Type 4/12 enclosure at a more economical price.

For details on these economical combination starter alternatives turn to Catalog Number Selection, page F105.

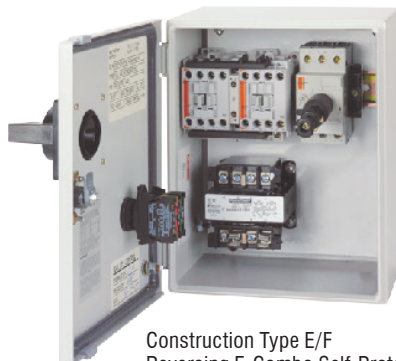

Construction Type E/F
Reversing E-Combo Self-Protected
Motor Controller

See page F105 for
Type E/F
Combination
Starter
Control Panels

NEMA Starters for HVAC/R

NEMA-Sized Starters For Heavy Duty Commercial & Industrial Applications

The Sprecher + Schuh HVAC/R Program is designed to simplify the selection of starters for HVAC/R market opportunities. Sprecher + Schuh through-the-door combination starters for HVAC/R applications provide an alternative to flange-operated combination starters that are economical without sacrificing quality or robustness. For years, Sprecher + Schuh has built standard custom control panels for these applications to meet rigid consultant specifications and to comply with UL and NEC requirements.

NEMA Sized for all HVAC/R applications

Sprecher + Schuh offers a complete line of combination and non-combination starters suitable for almost any HVAC/R application in the industry. Standard HVAC/R starters range from NEMA Size 00 up to NEMA size 3 (50HP @460V AC).

Standard starters include Non-combination, Fusible, Non-Fusible and Molded Case Circuit Breaker disconnects. All sizes are available in metallic Type 1 General Purpose or Type 3R Outdoor Rain tight enclosures. Three-phase and Single-Phase styles are available. An additional factory assembled option is the fireman damper interface, especially designed for meeting the needs of building and contractor specifications for shut down control.



C
NEMA Starters



Fractional Manual Starters



KWIKstarters

HVAC/R Program Features

- Fractional Manual Starters for easy, simple starting to 1 HP
- KWIKstarters for a quick solution, built from stock and easily assembled
- Robust, quality core components and accessories
- Multiple disconnect options in a wide range of sizes
- Wide range of choices to fit a variety of building automation needs

Customized for You

Almost all HVAC/R focused products can be customized to fit the exact needs of your building automation project. From simple starting of roof-top compressors and ventilation fans, to complete pump panel solutions for industrial chillers, we've got you covered.



Non-combination Starter



Fusible Combination Starter



Fireman Damper Options

Fractional Manual Starters

Easy, simple starting of Motors up to 1 HP

Sprecher + Schuh Fractional Manual Starters (FMS) consist of a snap switch combined with a thermal overload device operating on the solder-ratchet principle. To reset the overload mechanism, the switch lever is moved to the OFF position. The motor can be restarted by simply pushing the switch lever to the ON position. The switch is designed to prevent being held closed under a sustained motor overload.

Easy to Order

FMS Starters are easy to order. Simply choose a 1-Pole or 2-Pole with or without the Neon pilot light and then order the required Heater Element. You're done!

Typical Applications

Starting and overload protection of small 1-phase 115...230V AC/DC or 277 VAC motors used on the following applications:

- Unit heaters
- Fans
- Stokers
- Pumps
- Refrigeration compressors

NEMA Starters



Fractional Manual Starter

	Ratings (HP)		Poles ②	Type 1 General Purpose Surface Mounting Catalog Number
	115...230V AC	277V AC		
	Toggle Switch Only			
	1	1	1-Pole	FMS-TAX4
	1	1	2-Pole	FMS-TAX5
	Toggle Switch with Neon Pilot Light (115 or 230V)			
1	1	1-Pole	FMS-TAX216	
1	1	2-Pole	FMS-TAX109	

Heater Element (Required) ①

Full Load Amps	Catalog Number
0.17	P1
0.21	P2
0.25	P3
0.32	P4
0.39	P5
0.46	P6
0.57	P7
0.71	P8
0.79	P9
0.87	P10
0.98	P11
1.08	P12
1.19	P13
1.30	P14
1.43	P15
1.58	P16
1.75	P17
1.88	P18
2.13	P19
2.40	P20
2.58	P21
2.92	P22
3.09	P23
3.32	P24
3.37	P25
4.16	P26
4.51	P27
4.93	P28
5.43	P29
6.03	P30
6.83	P31
7.72	P32
8.24	P33
8.90	P34
9.60	P35
10.8	P36
12.0	P37
13.5	P38
15.2	P39

Optional Locking Attachment

	Accessory	Catalog Number
	Locking Attachment For locking toggle switch in ON or OFF position.	FMS-N1

Selecting Heater Elements ③

The "Full Load Amps" listed in the table can be used for heater element selection. The rating of the relay in amperes at 40°C is 115% of the "Full Load Amps" (FLA) listed for the catalog number. Refer to the motor nameplate for the full load current, the service factor, and/or the motor classification by application and temperature rise. Use this motor nameplate information, the application rules and the FLA listed in the table to determine the Heater Element catalog number for motors rated for Continuous Duty.

1. *For the Same Temperature at the Controller and Motor* : Select the Heater Element with the listed FLA nearest the full load value shown on the motor nameplate.
2. *For Higher Temperature at the Controller than at the Motor* : If the full load current value shown on the motor nameplate is between the listed FLAs, select the Heater Element with the next higher value.
3. *For a Lower Temperature at the Controller than at the Motor* : If the full load current value shown on the motor nameplate is between the listed FLAs, select the Heater Element with the next lower value.
4. *All other motors rated for continuous duty* (includes motors with marked service factor 1.0): Select the Heater Element one rating smaller than determined by rules in 1, 2 and 3.

Ordering Instructions

Order FMS Catalog Number
Order Required FMS Heater Element(s) ①
Order Optional FMS Locking Attachment

- ① One heater is required for 1-pole or 2-pole applications. See schematic on next page.
- ② Two-pole selections are applicable for 3/4 HP at 115...230V DC.
- ③ Rule 2 and 3 temperature difference not to exceed more than 10°C (18°F).

Technical Information

Eutectic Operation

Thermal overload devices using the eutectic alloy method are spring loaded in the normal, or reset, position. When the heater is cold, the solder is solid and holding the spring loaded ratchet. When FLA is passed through the heater, and if excess current flows, then the solder will melt and allow the ratchet mechanism to turn. This result trips the device. The device is reset by turning the switch to the OFF position and allowing it to cool.

P.L.: Pilot Light (Optional)

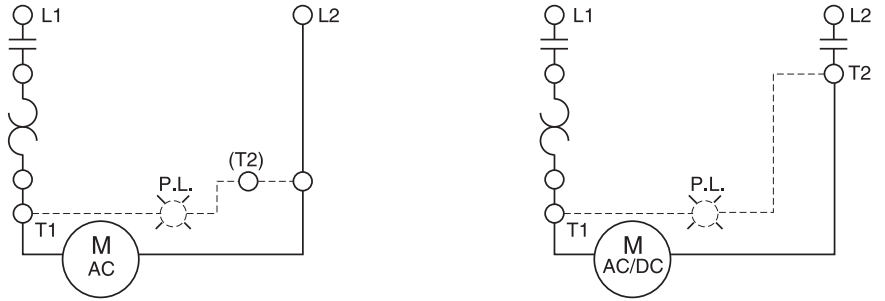

1-POLE

2-POLE

Standards Compliance

- UL 508
- EN60947-4-1
- CSA C22.2, No. 14

Certifications

- UL Listed - Enclosed Products (File No. E14841; Guide No. NLRV)
- CSA Certified (File No. LR 1234)
- American Bureau of Shipping (ABS)
- CE marked

Trip Time

- Class 20
- Reset Time: The actual time to reset will vary based on the ambient temperature surrounding the overload. Under most conditions, it will take from approximately 90 seconds up to 5 minutes for the solder to solidify enough for the overload to be reset. Until this happens, the overload will not be able to be reset by pressing on the reset button. The ratchet assembly inside the overload block will spin freely until the solder has solidified.

Dimensions

FMS Type 1 General Purpose Surface Mounting

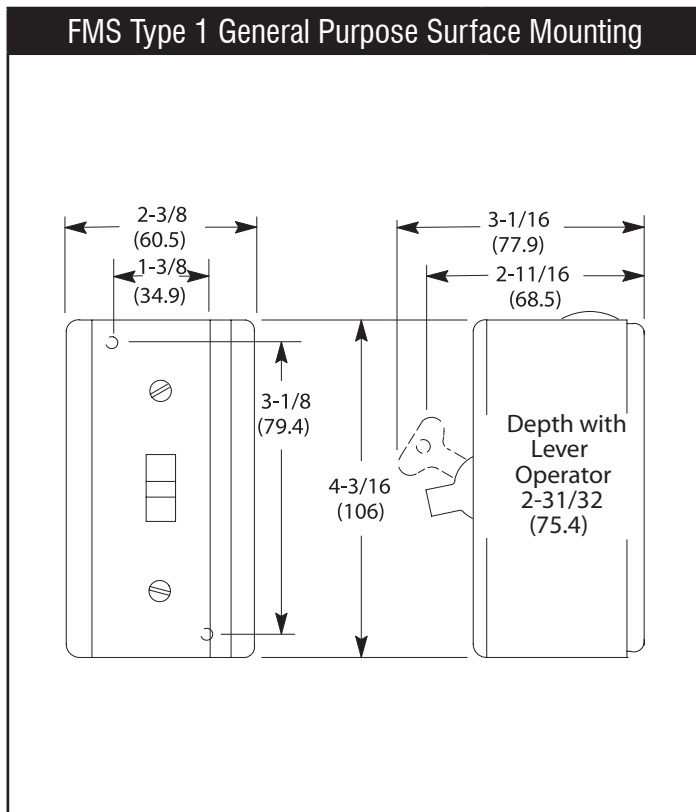

TIME - Current Characteristics at 40°C

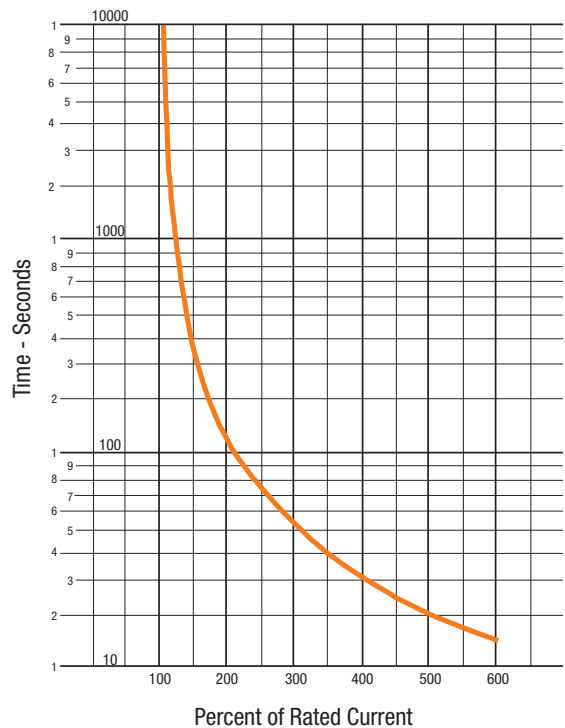

NOTE: Trip will occur at 115% of FLA

NEMA Labeled KWIKstarters

Preassembled or build from stock – Easy, fast, economical enclosed starters for applications up to 30HP

NEMA Starters



Most KWIKstarters are equipped with Thermal Overload protection as standard

Sprecher + Schuh offers a broad selection of pre-assembled or “build-from-stock” starters housed in a high impact, non-metallic, cUL Approved, Type 1, 12, 4, 4X enclosure. Built for convenience, space savings and economy, KWIKstarters are efficiently designed to use stock CA7 contactors and CEP7 or CT7N overloads usually stocked by distributors. Contactor and overload are either pre-wired and pre-mounted onto the enclosure’s built-in DIN-rail or may be ordered as separate components. Ample knockouts and open terminals guarantee quick, no fuss wiring.

Sized for most industrial applications

KWIKstarters control motors up to 30HP @ 460V in two sizes of enclosures, measuring only 208 x 98mm (7.4” x 3.9”) or 250 x 125mm (9.85” x 4.93”) for our larger sizes. This covers over 85% of industrial motor control applications in a very compact package that can be mounted adjacent to or directly on equipment.

Thermal overload protection

KWIKstarters, sized 9 to 23 amps, are equipped with Sprecher + Schuh’s CT7N bimetallic thermal overload relay as standard. The consistent high quality of our thermal overload relays is ensured by a complex current calibration procedure performed after each unit is at full operating temperature.

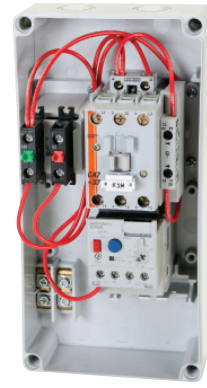

KWIKstarters are also available with our advanced CEP7 Solid State Overload Relay (select appropriate overload relay code for this option)

Solid state overload options

KWIKstarters, sizes 9 to 23 amps, can also be supplied with Sprecher + Schuh’s CEP7 solid state overload relay. The CEP7 Overload is standard on larger (sizes 30 to 43 amps) and all reversing KWIKstarters. The CEP7 solid state overload relays measure motor current directly through integrated current transformers and on board electronics. The electronics provide increased accuracy and numerous other advantages over electromechanical relays. Learn more about Sprecher + Schuh overload relays in Section B of this catalog.

Build it yourself...

KWIKstarters may be assembled from stock components. Just grab a CA7 contactor and overload of your choice and snap them into the enclosure. Minimal wiring is required and assembly can be completed in minutes.







Start-Stop or Reset only

Hand-Off-Auto with Pilot Light

Multi-Function

Forward-Stop-Reverse options

NEMA KWIKstarters with CT7N or CEP7 Overload Relays ①⑥

Cover Control/ Enclosure (KS7-COS1/COS4)	NEMA Size	Maximum Horsepower						Total Aux. Contacts Installed		cUL Approved- Type 1/12/4/4X IP66	D I M
		Single Ø		Three Ø				NO	NC		
		115V	230V	200V	230V	460V	575V				
	KWIKstarter with Start & Raised Stop with AC Coil ④⑤										
	00	.33	1	~	~	~	~	1 ②	0	CBKN7-12-*-◆-P2 CAKN7-12-*-◆-P2	Q1
	0	1	2	~	~	~	~	1 ②	0	CBKN7-16-*-◆-P2 CAKN7-16-*-◆-P2	Q1
	~	~	~	1.5	1.5	2	2				
	~	~	~	3	3	5	5				
	~	~	~	~	~	~	~				
	KWIKstarter with Start & Raised Stop with Electronic DC Coil ⑦										
	00	.33	1	~	~	~	~	1 ②	0	CBKN7-12E-*-◆-P2 CAKN7-12E-*-◆-P2	Q1
	0	1	2	~	~	~	~	1 ②	0	CBKN7-16E-*-◆-P2 CAKN7-16E-*-◆-P2	Q1
	~	~	~	1.5	1.5	2	2				
	~	~	~	3	3	5	5				
	~	~	~	~	~	~	~				
	KWIKstarter with Reset with AC Coil										
	00	.33	1	~	~	~	~	1 ②	0	CBKN7-12-*-◆-P0 CAKN7-12-*-◆-P0	Q1
	0	1	2	~	~	~	~	1 ②	0	CBKN7-16-*-◆-P0 CAKN7-16-*-◆-P0	Q1
	~	~	~	1.5	1.5	2	2				
	~	~	~	3	3	5	5				
	~	~	~	~	~	~	~				
	KWIKstarter with Reset with Electronic DC Coil ⑦										
	00	.33	1	~	~	~	~	1 ②	0	CBKN7-12E-*-◆-P0 CAKN7-12E-*-◆-P0	Q1
	0	1	2	~	~	~	~	1 ②	0	CBKN7-16E-*-◆-P0 CAKN7-16E-*-◆-P0	Q1
	~	~	~	1.5	1.5	2	2				
	~	~	~	3	3	5	5				
	~	~	~	~	~	~	~				

Coil Codes ⑤⑦

A.C. Coil Code	Voltage Range		Control Source	
	50 Hz	60 Hz	CBK7	CAK7
24Z	24V	24V	Separate	Separate
120	110V	120V	Common	Separate
220W	200-220V	208-240V	Common	Common
277	240V	277V	Common	~
415	400-415V	~	~	Common
480	440V	480V	~	Common
600	550V	600V	~	Common
D.C. Coil Code	Voltage Range			
	VDC			
12E	12V			
24E	24V			

Control Circuit Note

Common: Coils are assumed to be common with the line voltage and will be connected to the line source (L1-L2) per the table.



Separate: Coils are assumed to be from a separate source and will not be connected to the line source per the table.

Ordering Instructions

Specify Catalog Number	
Replace (*) with Coil Code	See this page See page C101.14
Replace (◆) with O/L Relay	
Important Note: KWIKstarters are only designed to accommodate CT7N Thermal Overload Relays or CEP7 Solid State Overload Relays. Select O/L Relay Code from page C101.14.	

- ① KWIKstarters are designed for three-wire control circuits. Two-wire (maintain) control can be accomplished by adding pushbutton latch KS7-PLA.
- ② A special design NO auxiliary contact (Cat.# KS7-PCK) is used as the holding circuit interlock, as well as, the START button interface. It is not available for other use.
- ③ Refer to page C101.17 for dimensional information.
- ④ STOP button also functions as RESET button. Plastic Bezel is standard.
- ⑤ Other voltages available, see Section A.
- ⑥ Use CT7N or CEP7-ED/CEP7-EE overload.
- ⑦ CAN7-12E...16E with electronic coils are not interchangeable with non-electronic DC or AC coils.

NEMA KWIKstarters with CT7N or CEP7 Overload Relays with H-O-A and Light ①②③⑤⑥

Cover Control/ Enclosure (KS7-COS1)	NEMA Size	Maximum Horsepower						Total Aux. Contacts Installed		cUL Approved- Type 1/12/4/4X IP66	DIM
		Single Ø		Three Ø				NO	NC		
		115V	230V	200V	230V	460V	575V			Catalog Number	
NEMA KWIKstarter with Reset and H-O-A Selector Switch and Light with AC Coil											
	00	.33	1	~	~	~	~	1 ⑥	0	CBKN7-12-*-◆-P0+1R7	Q1
		~	~	1.5	1.5	2	2			CAKN7-12-*-◆-P0+1R7	
	0	1	2	~	~	~	~	1 ⑥	0	CBKN7-16-*-◆-P0+1R7	Q1
		~	~	3	3	5	5			CAKN7-16-*-◆-P0+1R7	
NEMA KWIKstarter with Reset and H-O-A Selector Switch and Light with Electronic DC Coil ⑦											
	00	.33	1	~	~	~	~	1 ⑥	0	CBKN7-12E-*-◆-P0+1R7	Q1
		~	~	1.5	1.5	2	2			CAKN7-12E-*-◆-P0+1R7	
	0	1	2	~	~	~	~	1 ⑥	0	CBKN7-16E-*-◆-P0+1R7	Q1
		~	~	3	3	5	5			CAKN7-16E-*-◆-P0+1R7	

Coil Codes ⑦

A.C. Coil Code	Voltage Range		Control Source	
	50 Hz	60 Hz	CBK7	CAK7
24Z	24V	24V	Separate	Separate
120	110V	120V	Common	Separate
220W	200V-220V	208V-240V	Common	Common
D.C. Coil Code	Voltage Range			
	VDC			
12E	12V			
24E	24V			

Control Circuit Note

Common: Coils and pilot devices in the control circuit are assumed to be common with the line voltage and will be connected to the line source (L1-L2) per the table.

Separate: Coils and pilot devices in the control circuit are assumed to be from a separate source and will not be connected to the line source per the table. Line Voltage not listed: (i.e.: 480 and 575 VAC) require a separate control source (i.e.: 120 VAC). D7D pilot devices are rated 300 VAC maximum.

Ordering Instructions

Specify Catalog Number	
Replace (*) with Coil Code Replace (◆) with O/L Relay	See this page See page C101.14
Important Note: KWIKstarters are only designed to accommodate CT7N Thermal Overload Relays or CEP7 Solid State Overload Relays. Select O/L Relay Code from page C101.14.	

- ① This is a factory assembly. The KS7-COS1 (Q1) enclosure does not include knock-outs for field assembly of this starter.
- ② Uses D7D-P4N Red Monolithic "Run" pilot light with LED bulb. Pilot light voltage to match coil voltage for 24, 120, 240 VAC control. Red "Run" Light can be changed for Green. Change +1R7 to +1G7. For example, CAKN7-12-*-◆-P0+1R7 becomes CAKN7-12-*-◆-P0+1G7.
- ③ Uses D7D-SM32x20 Monolithic 3-position selector switch for maintain control, HAND-OFF-AUTO function with legend plate.
- ④ Refer to page C101.10 for wiring and C101.17 for dimensional information. This is a clam-shell enclosure design with wires to cover controls.
- ⑤ Uses CT7N or CEP7-ED/CEP7-EE overload.
- ⑥ One NO auxiliary for customer use. There is no room for additional auxiliaries.
- ⑦ CAN7-12E...16E with electronic coils are not interchangeable with non-electronic DC or AC coils.

NEMA KWIKstarters with CEP7 Overload Relays ①

Enclosure (KS7-C2S4)	NEMA Size	Maximum Horsepower						Total Aux. Contacts Installed		cUL Approved-Type 1/12/4/4X IP66	DIM
		Single Ø		Three Ø				NO	NC		
		115V	230V	200V	230V	460V	575V			Catalog Number	
	NEMA KWIKstarters with AC Coil										
	1	2	3	~	~	~	~	1	0	CBKN7-37-*-ETD-P▼ CAKN7-37-*-♦-P▼	Q2
	2	3	7.5	~	~	~	~	1	0	CBKN7-43-*-ETD-P▼ CAKN7-43-*-♦-P▼	Q2
	NEMA KWIKstarters with Electronic DC Coil ④										
	1	3	5	~	~	~	~	1	0	CBKN7-37E-*-ETD-P▼ CAKN7-37E-*-♦-P▼	Q2
	2	3	7.5	~	~	~	~	1	0	CBKN7-43E-*-ETD-P▼ CAKN7-43E-*-♦-P▼	Q2

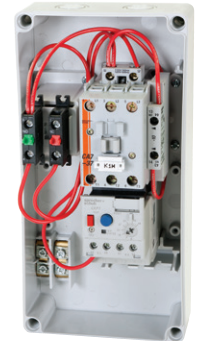

NEMA Starters

Coil Codes (*) ④⑤⑦

A.C. Coil Code	Voltage Range		Control Source	
	50 Hz	60 Hz	CBK7	CAK7
24Z	24V	24V	Separate	Separate
120	110V	120V	Common	Separate
220W	200-220V	208-240V	Common	Common
277	240V	277V	Common	~
415	400-415V	~	~	Common
480	440V	480V	~	Common
600	550V	600V	~	Common

D.C. Coil Code	Voltage Range VDC
12E	12V
24E	24V
48E	48-72V
220E	220-250V

AC Control Circuit Note

Common: Coils and pilot devices in the control circuit are assumed to be common with the line voltage and will be connected to the line source (L1-L2) per the table.

Separate: Coils and pilot devices in the control circuit are assumed to be from a separate source and will not be connected to the line source per the table. Pilot lights are 240 VAC maximum.

Replace ♦ with one of the following Overload Relays

For use with KWIKstarter...	Amp Range	Overload Relay Code (♦)	Catalog Number (of Overload Relay used)
3-Phase / Manual Reset / Class 10			
CAK7-30...43	1.0...5.0	D1CD	CEP7-ED1CD
	3.2...16	D1DD	CEP7-ED1DD
	5.4...27	D1ED	CEP7-ED1ED
	9...45	D1FD	CEP7-ED1FD
3-Phase / Auto or Manual Reset / Class 10, 15, 20, 30			
CAK7-30...43	1.0...5.0	ECD	CEP7-EECD
	3.2...16	EDD	CEP7-EEDD
	5.4...27	EED	CEP7-EEED
	9...45	EFD	CEP7-EEFD

- ① Use CEP7-ED/CEP7-EE overloads only. Single-phase applications utilize CEP7S-EETD only.
- ② Plastic Bezel is standard. Pilot Device options include D7-BX_ Base Mounted contact blocks. See page H69 for more information.
- ③ Refer to page C101.15 for wiring diagram and C101.17 for dimensional information.
- ④ CAN7-37E...43E with electronic coils are not interchangeable with non-electronic DC or AC coils.

Pilot Device Options (includes reset) ②⑥

Pushbutton Description	Replace ▼ in catalog number with
START-STOP Multi-function (shown)	3U
I-O Multi-function	4U
OFF-ON 2-Position Selector switch	6
Pilot Light Red (LED) with START-STOP Multi-function	1R3U
Pilot Light Red (LED) with I-O Multi-function	1R4U

Optional CA7 Modifications (Factory Assembled)

Description	Add to end of catalog number
Electronic Interface	-JE
Surge Suppressor RD	-C
Surge Suppressor Varistor	-V
Additional NC Contact	-L01
Additional NO Contact	-L10

Ordering Instructions

Specify Catalog Number	
Replace (*) with Coil Code	See this page only
Replace (♦) with O/L Relay	
Replace (▼) with Pilot Device Option	

- ⑤ Other voltages available, see Section A.
- ⑥ One and only one Pilot Device option must be selected. If Pilot Light option is selected then coil voltage must be 24V AC or DC, 120V or 240V AC only.
- ⑦ CPT not possible with KS7-C2S4 (Q2) enclosure.

Three Phase Reversing NEMA KWIKstarters with CEP7 Overload Relays ①③

Enclosure (KS7-COS4R)	NEMA Size	Maximum Horsepower				Total Aux. Contacts Installed		cUL Approved-Type 1/12/4/4X IP66	Catalog Number	DIM ⑥
		Three Ø				NO	NC			
		200V	230V	460V	575V					
	3-Phase FVR NEMA KWIKstarter with AC Coil									
	00	1.5	1.5	2	2	1	1	CAUKN7-12-*-*♦-P▼	Q3	
	0	3	3	5	5	1	1	CAUKN7-16-*-*♦-P▼	Q3	
	3-Phase FVR NEMA KWIKstarter with Electronic DC Coil									
	00	1.5	1.5	2	2	1	1	CAUKN7-12E-*-*♦-P▼	Q3	
0	3	3	5	5	1	1	CAUKN7-16E-*-*♦-P▼	Q3		



NEMA Starters

Coil Codes (*) ④⑤⑦

A.C. Coil Code	Voltage Range		Control Source		D.C. Coil Code	Voltage Range VDC
	50 Hz	60 Hz	CBK7	CAK7		
24Z	24V	24V	Separate	Separate	12E	12V
120	110V	120V	Common	Separate	24E	24V
220W	200-220V	208-240V	Common	Common	36E	36-48V
277	240V	277V	Common	~	48E	48-72V
415	400-415V	~	~	Common	110E	110-125V
480	440V	480V	~	Common	220E	220-250V
600	550V	600V	~	Common		

AC Control Circuit Note

Common: Coils and pilot devices in the control circuit are assumed to be common with the line voltage and will be connected to the line source (L1-L2) per the table.

Separate: Coils and pilot devices in the control circuit are assumed to be from a separate source and will not be connected to the line source per the table. Pilot lights are 240 VAC maximum.

Pilot Device Options (includes reset) ②③

Pushbutton Description	Replace ▼ in catalog number with
FOR-STOP-REV Multi-function (shown)	3U
UP-STOP-DOWN Multi-function	4U
OPEN-STOP-CLOSE Multi-function	5U
FOR-STOP-REV 3-Position Selector switch	6
UP-OFF-DOWN 3-Position Selector switch	7
OPEN-OFF-CLOSE 3-Position Selector switch	8
Overload Alarm Pilot Light	1Y
D7-N8 22mm Hole Plug	0

Optional CA7 Modifications (Factory Assembled)

Description (supplied on each contactor)	Add to end of catalog number
Electronic Interface	-2JE
Surge Suppressor RD	-2C
Surge Suppressor Varistor	-2V

Ordering Instructions

Specify Catalog Number	
Replace (*) with Coil Code	See this page only
Replace (♦) with O/L Relay	
Replace (▼) with Pilot Device Option	

Replace ♦ with one of the following Overload Relays

For use with KWIKstarter...	Amp Range	Overload Relay Code (♦)	Catalog Number (of Overload Relay used)
3-Phase / Manual Reset / Class 10			
CAUKN7-12..16 CAUKN7-12E..16E	0.1...0.5	D1AB	CEP7-ED1AB
	0.2...1.0	D1BB	CEP7-ED1BB
	1.0...5.0	D1CB	CEP7-ED1CB
	3.2...16	D1DB	CEP7-ED1DB
	5.4...27	D1EB	CEP7-ED1EB
3-Phase / Auto or Manual Reset / Class 10, 15, 20, 30			
CAUKN7-12..16 CAUKN7-12E..16E	0.1...0.5	EAB	CEP7-EEAB
	0.2...1.0	EBB	CEP7-EEBB
	1.0...5.0	ECB	CEP7-EECB
	3.2...16	EDB	CEP7-EEDB
	5.4...27	EEB	CEP7-EEEB

- ① Use CEP7-ED/CEP7-EE overloads only.
- ② Plastic Bezel is standard. Pilot Device options include D7-BX_ Base Mounted contact blocks. See page H69 for more information.
- ③ Refer to page C101.16 for wiring diagram and C101.17 for dimensional information.
- ④ CAN7-12E...16E with electronic coils are not interchangeable with non-electronic DC or AC coils.
- ⑤ Other voltages available, see Section A.
- ⑥ One Pilot Device option must be selected. Blanks are not available. If Pilot Light option is selected then Pilot Light must match Coil Voltage 24V AC or DC, 120V or 240V AC only.
- ⑦ CPT not possible with KS7-COS4R (Q3) enclosure.
- ⑧ One N.C. auxiliary contact is used for electrical interlocking. On CAUKN7 reversing starters, the N.C. contact comes from the Mechanical/Electrical Interlock unit (Cat# CM7-02).

Three Phase, Non-Reversing CAKN7 @ 200V AC KWIKstarter

NEMA Size	Max HP 3 Ø	Adjustment Range	Start-Stop Pushbutton or Multifunction with Reset	Reset Only	D I M ⑦
			Catalog Number	Catalog Number	
00	0.5	2.3...3.2	CAKN7-12-220W-AB32-P2 ① ② ③ ④	CAKN7-12-220W-AB32-P0 ① ② ④	Q1
	0.75	3.5...4.8	CAKN7-12-220W-AB48-P2 ① ② ③ ④	CAKN7-12-220W-AB48-P0 ① ② ④	
	1	4.5...6.3	CAKN7-12-220W-AB63-P2 ① ② ③ ④	CAKN7-12-220W-AB63-P0 ① ② ④	
	1.5	5.5...7.5	CAKN7-12-220W-AB75-P2 ① ② ③ ④	CAKN7-12-220W-AB75-P0 ① ② ④	
0	2	7.2...10	CAKN7-16-220W-AC10-P2 ① ② ③ ④	CAKN7-16-220W-AC10-P0 ① ② ④	Q1
	3	9.0...12.5	CAKN7-16-220W-AC12-P2 ① ② ③ ④	CAKN7-16-220W-AC12-P0 ① ② ④	
1	5	5.4...27	CAKN7-37-220W-D1ED-P3U ⑤ ⑥		Q2
	7.5	9...45	CAKN7-37-220W-D1FD-P3U ⑤ ⑥		
2	10	9...45	CAKN7-43-220W-D1FD-P3U ⑤ ⑥		



CAK7-12...16 Amp
(Q1 Dim – Start/Stop)



CAK7-12...16 Amp
(Q1 Dim - Reset) Only



CAK7-37...43 Amp
(Q2 Dim)

NEMA Starters

Three Phase, Non-Reversing CAKN7 @ 230V AC KWIKstarter

NEMA Size	Max HP 3 Ø	Adjustment Range	Start-Stop Pushbutton or Multifunction with Reset	Reset Only	D I M ⑦
			Catalog Number	Catalog Number	
00	0.5	1.8...2.5	CAKN7-12-220W-AB25-P2 ① ② ③ ④	CAKN7-12-220W-AB25-P0 ① ② ④	Q1
	0.75	2.9...4.0	CAKN7-12-220W-AB40-P2 ① ② ③ ④	CAKN7-12-220W-AB40-P0 ① ② ④	
	1	2.3...3.2	CAKN7-12-220W-AB48-P2 ① ② ③ ④	CAKN7-12-220W-AB48-P0 ① ② ④	
	1.5	5.5...7.5	CAKN7-12-220W-AB75-P2 ① ② ③ ④	CAKN7-12-220W-AB75-P0 ① ② ④	
0	2	5.5...7.5	CAKN7-16-220W-AB75-P2 ① ② ③ ④	CAKN7-16-220W-AB75-P0 ① ② ④	Q1
	3	9.0...12.5	CAKN7-16-220W-AC12-P2 ① ② ③ ④	CAKN7-16-220W-AC12-P0 ① ② ④	
1	5	5.4...27	CAKN7-37-220W-D1ED-P3U ⑤ ⑥		Q2
	7.5	5.4...27	CAKN7-37-220W-D1ED-P3U ⑤ ⑥		
2	10	9...45	CAKN7-43-220W-D1FD-P3U ⑤ ⑥		Q2
	15	9...45	CAKN7-43-220W-D1FD-P3U ⑤ ⑥		

Full Voltage Non-Reversing (FVNR)

Features include:

- NEMA-sized CAN7 contactor
- CT7N Thermal Overload Relay (Q1 Dim) or CEP7 Solid State Overload Relay (Q1/Q2 Dim)
- Green Start pushbutton (Q1 Dim – Start/Stop)
- Red Raise Stop pushbutton (Q1 Dim – Start/Stop)
- Reset pushbutton (Q1 Dim – Reset)
- 1-NO auxiliary for customer use
- Non-Metallic Enclosure Type 1/12/4/4X, IP66
- Pre-wired for easy installation
- Ideal for compressors, fans, blowers

Three Phase, Non-Reversing CAKN7 @ 480V AC KWIKstarter

NEMA Size	Max HP 3 Ø	Adjustment Range	Start-Stop Pushbutton or Multifunction with Reset	Reset Only	D I M ⑦
			Catalog Number	Catalog Number	
00	0.5	0.9...1.3	CAKN7-12-480-AB13-P2 ① ② ③ ④	CAKN7-12-480-AB13-P0 ① ② ④	Q1
	0.75	1.4...2.0	CAKN7-12-480-AB20-P2 ① ② ③ ④	CAKN7-12-480-AB20-P0 ① ② ④	
	1	1.8...2.5	CAKN7-12-480-AB25-P2 ① ② ③ ④	CAKN7-12-480-AB25-P0 ① ② ④	
	1.5	2.3...3.2	CAKN7-12-480-AB32-P2 ① ② ③ ④	CAKN7-12-480-AB32-P0 ① ② ④	
	2	2.9...4.0	CAKN7-12-480-AB40-P2 ① ② ③ ④	CAKN7-12-480-AB40-P0 ① ② ④	
0	3	4.5...6.3	CAKN7-16-480-AB63-P2 ① ② ③ ④	CAKN7-16-480-AB63-P0 ① ② ④	Q1
	5	7.2...10	CAKN7-16-480-AC10-P2 ① ② ③ ④	CAKN7-16-480-AC10-P0 ① ② ④	
1	7.5	3.2...16	CAKN7-37-480-D1DD-P3U ⑤ ⑥		Q2
	10	5.4...27	CAKN7-37-480-D1ED-P3U ⑤ ⑥		
2	15	9...45	CAKN7-43-480-D1FD-P3U ⑤ ⑥		Q2
	20	9...45	CAKN7-43-480-D1FD-P3U ⑤ ⑥		
	25	9...45	CAKN7-43-480-D1FD-P3U ⑤ ⑥		

- ① KWIKstarters are designed for three-wire control circuits. Two-wire (maintain) control can be accomplished by adding pushbutton latch KS7-PLA.
- ② A special design NO auxiliary contact (Cat.# KS7-PCK) is used as the holding circuit interlock, as well as, the START button interface. It is not available for other use.
- ③ STOP button also functions as RESET button. Plastic bezel is standard.
- ④ Use CT7N or CEP7-ED/CEP7-EE overload.
- ⑤ Use CEP7-ED/CEP7-EE overloads only. Single-phase applications utilize CEP7S-EETD only.
- ⑥ Plastic bezel is standard. Pilot device options include D7-BX_ base Mounted contact blocks. See page H69 for more information.
- ⑦ Refer to page C100.18 for dimensional information

Single Phase, Non-Reversing CBKN7 @ 115V AC KWIKstarter ①⑥

NEMA Size	Max HP 1 Ø	Adjustment Range	Start-Stop Pushbutton or Multifunction with Reset ②④⑤	Reset Only	D I M ③
			Catalog Number	Catalog Number	
00	0.25	4.5...6.3	CBKN7-12-120-AB63-P2	CBKN7-12-120-AB63-P0	Q1
	0.33	5.5...7.5	CBKN7-12-120-AB75-P2	CBKN7-12-120-AB75-P0	
0	0.5	9...12.5	CBKN7-16-120-AC12-P2	CBKN7-16-120-AC12-P0	
	0.75	11.3...16	CBKN7-16-120-AC16-P2	CBKN7-16-120-AC16-P0	
	1	15...20	CBKN7-16-120-AC20-P2	CBKN7-16-120-AC20-P0	
1	1.5	9...45	CBKN7-37-120-ETD-P3U ⑦⑧		Q2
	2	9...45	CBKN7-37-120-ETD-P3U ⑦⑧		
2	3	9...45	CBKN7-43-120-ETD-P3U ⑦⑧		



CBKN7-12...16 Amp



CBKN7-12...16
Amp Reset Only



CBKN7-37...43 Amp

Single Phase, Non-Reversing CBKN7 @ 230V AC KWIKstarter ①⑥

NEMA Size	Max HP 1 Ø	Adjustment Range	Start-Stop Pushbutton or Multifunction with Reset ②④⑤	Reset Only	D I M ③
			Catalog Number	Catalog Number	
00	0.25	2.3...3.2	CBKN7-12-220W-AB32-P2	CBKN7-12-220W-AB32-P0	Q1
	0.33	3.5...4.8	CBKN7-12-220W-AB48-P2	CBKN7-12-220W-AB48-P0	
	0.5	4.5...6.3	CBKN7-12-220W-AB63-P2	CBKN7-12-220W-AB63-P0	
	0.75	5.5...7.5	CBKN7-12-220W-AB75-P2	CBKN7-12-220W-AB75-P0	
	1	7.2...10	CBKN7-12-220W-AC10-P2	CBKN7-12-220W-AC10-P0	
0	1.5	9...12.5	CBKN7-16-220W-AC12-P2	CBKN7-16-220W-AC12-P0	Q1
	2	11.3...16	CBKN7-16-220W-AC16-P2	CBKN7-16-220W-AC16-P0	
1	3	9...45	CBKN7-37-220W-ETD-P3U ⑦⑧		Q2
2	5	9...45	CBKN7-43-220W-ETD-P3U ⑦⑧		
	7.5	9...45	CBKN7-43-220W-ETD-P3U ⑦⑧		

Full Voltage Non-Reversing (FVNR)

Features include:

- NEMA-sized CAN7 contactor
- CT7N Thermal Overload Relay or CEP7 Solid State Overload Relay
- Green Start pushbutton
- Red Raise Stop pushbutton
- Reset pushbutton
- 1-NO auxiliary for customer use
- Non-Metallic Enclosure Type 1/12/4/4X, IP66
- Pre-wired for easy installation
- Ideal for compressors, fans, blowers

① KWIKstarters are designed for three-wire control circuits. Two-wire (maintain) control can be accomplished by adding pushbutton latch KS7-PLA.

② A special design NO auxiliary contact (Cat.# KS7-PCK) is used as the holding circuit interlock, as well as, the START button interface. It is not available for other use.

③ Refer to page C101.15 for wiring diagram and C101.17 for dimensional information.

④ STOP button also functions as RESET button. Plastic Bezel is standard.

⑤ Other voltages available, see Section A.

⑥ Use CT7N or CEP7-ED/CEP7-EE overload. CBKN7-37...43 Single-phase applications utilize CEP7S-EETD only.

⑦ Plastic Bezel is standard. Pilot Device options include D7-BX_ Base Mounted contact blocks. See page H69 for more information.

⑧ CPT not possible with KS7-C2S4 (Q2) enclosure.

Three Phase, Non-Reversing CAKN7 @ 200V AC KWIKstarter ①②③⑤⑥

NEMA Size	Max HP 3 Ø	Adjustment Range	with CT7N Overload Relay	Adjustment Range	with CEP7 Overload Relay	D I M ④
			Catalog Number		Catalog Number	
00	0.5	2.3...3.2	CAKN7-12-220W-AB32-P0+1R7	1...5	CAKN7-12-220W-D1CB-P0+1R7	Q1
	0.75	3.5...4.8	CAKN7-12-220W-AB48-P0+1R7	1...5	CAKN7-12-220W-D1CB-P0+1R7	
	1	4.5...6.3	CAKN7-12-220W-AB63-P0+1R7	3.2...16	CAKN7-12-220W-D1DB-P0+1R7	
	1.5	5.5...7.5	CAKN7-12-220W-AB75-P0+1R7	3.2...16	CAKN7-12-220W-D1DB-P0+1R7	
0	2	7.2...10	CAKN7-16-220W-AC10-P0+1R7	3.2...16	CAKN7-16-220W-D1DB-P0+1R7	
	3	9...12.5	CAKN7-16-220W-AC12-P0+1R7	3.2...16	CAKN7-16-220W-D1DB-P0+1R7	



C

NEMA Starters

Three Phase, Non-Reversing CAKN7 @ 230V AC KWIKstarter ①②③⑤⑥

NEMA Size	Max HP 3 Ø	Adjustment Range	with CT7N Overload Relay	Adjustment Range	with CEP7 Overload Relay	D I M ④
			Catalog Number		Catalog Number	
00	0.5	1.8...2.5	CAKN7-12-220W-AB25-P0+1R7	1...5	CAKN7-12-220W-D1CB-P0+1R7	Q1
	0.75	2.9...4	CAKN7-12-220W-AB40-P0+1R7	1...5	CAKN7-12-220W-D1CB-P0+1R7	
	1	3.5...4.8	CAKN7-12-220W-AB48-P0+1R7	3.2...16	CAKN7-12-220W-D1DB-P0+1R7	
	1.5	5.5...7.5	CAKN7-12-220W-AB75-P0+1R7	3.2...16	CAKN7-12-220W-D1DB-P0+1R7	
0	2	5.5...7.5	CAKN7-16-220W-AB75-P0+1R7	3.2...16	CAKN7-16-220W-D1DB-P0+1R7	
	3	9...12.5	CAKN7-16-220W-AC12-P0+1R7	3.2...16	CAKN7-16-220W-D1DB-P0+1R7	

Full Voltage Non-Reversing (FVNR)

Features include:

- NEMA-sized CAN7 contactor
- CT7N Thermal Overload Relay or CEP7 Solid State Overload Relay
- Red Pilot Light
- Hand-Off-Auto Selector Switch
- Reset pushbutton
- 1-NO auxiliary for customer use
- Non-Metallic Enclosure Type 1/12/4/4X, IP66
- Pre-wired for easy installation
- Ideal for compressors, fans, blowers

Single Phase, Non-Reversing CBKN7 @ 115V AC KWIKstarter ①②③⑤⑥



NEMA Size	Max HP 3 Ø	Adjustment Range	with CT7N Overload Relay	Adjustment Range	with CEP7 Overload Relay	D I M ④
			Catalog Number		Catalog Number	
00	0.25	4.5...6.3	CBKN7-12-120-AB63-P0+1R7	3.2...16	CBKN7-12-120-ERB-P0+1R7	Q1
	0.33	5.5...7.5	CBKN7-12-120-AB75-P0+1R7	3.2...16	CBKN7-12-120-ERB-P0+1R7	
0	0.5	9...12.5	CBKN7-16-120-AC12-P0+1R7	5.4...27	CBKN7-16-120-ESB-P0+1R7	
	0.75	11.3...16	CBKN7-16-120-AC16-P0+1R7	5.4...27	CBKN7-16-120-ESB-P0+1R7	
	1	15...20	CBKN7-16-120-AC20-P0+1R7	5.4...27	CBKN7-16-120-ESB-P0+1R7	

Single Phase, Non-Reversing CBKN7 @ 230V AC KWIKstarter ①②③⑤⑥



NEMA Size	Max HP 3 Ø	Adjustment Range	with CT7N Overload Relay	Adjustment Range	with CEP7 Overload Relay	D I M ④
			Catalog Number		Catalog Number	
00	0.25	2.3...3.2	CBKN7-12-220W-AB32-P0+1R7	3.2...16	CBKN7-12-220W-ERB-P0+1R7	Q1
	0.33	2.9...4.0	CBKN7-12-220W-AB48-P0+1R7	3.2...16	CBKN7-12-220W-ERB-P0+1R7	
	0.5	4.5...6.3	CBKN7-12-220W-AB63-P0+1R7	3.2...16	CBKN7-12-220W-ERB-P0+1R7	
	0.75	5.5...7.5	CBKN7-12-220W-AB75-P0+1R7	3.2...16	CBKN7-12-220W-ERB-P0+1R7	
	1	7.2...10	CBKN7-12-220W-AC10-P0+1R7	3.2...16	CBKN7-12-220W-ERB-P0+1R7	
0	1.5	9...12.5	CBKN7-16-220W-AC12-P0+1R7	5.4...27	CBKN7-16-220W-ESB-P0+1R7	
	2	11.3...16	CBKN7-16-220W-AC16-P0+1R7	5.4...27	CBKN7-16-220W-ESB-P0+1R7	

- ① This is a factory assembly. The KS7-C0S1 (Q1) enclosure does not include knock-outs for field assembly of this starter.
- ② Uses D7D-P4N_ Red Monolithic "Run" pilot light with LED bulb. Pilot light voltage to match coil voltage for 24, 120, 240 VAC control. Red "Run" Light can be changed for Green. Change +1R7 to +1G7. For example, CAKN7-12-~~*~~-~~◆~~-P0+1R7 becomes CAKN7-12-~~*~~-~~◆~~-P0+1G7.
- ③ Uses D7D-SM32x20 Monolithic 3-position selector switch for maintain control, HAND-OFF-AUTO function with legend plate.
- ④ Refer to page C101.10 for wiring and C101.17 for dimensional information. This is a clam-shell enclosure design with wires to cover controls.
- ⑤ Uses CT7N or CEP7-ED/CEP7-EE overload.
- ⑥ One NO auxiliary for customer use. There is no room for additional auxiliaries.

KWIKstarter 9...23A Enclosures with CT7N or CEP7 Overload Relays ①②

Component	Description	For Use With		Environmental Approvals	Catalog Number
		Contactors	Overload		
	Flush Green START / Extended Red STOP - Mechanical interface auxiliary contact (KS7-PCK) included in enclosure.	CA7-9...23	CT7N CEP7-ED1 CEP7-EE	cUL Type 1/12/4/4x IEC IP66	KS7-COS4
	Blue RESET Only	CA7-9...23	CT7N CEP7-ED1 CEP7-EE	cUL Type 1/12/4/4x IEC IP66	KS7-COS1



KWIKstarter Enclosures for use with CA7 Contactors and Overload Relays ①③

Component	Description	For Use With		Environmental Approvals	Catalog Number
		Contactors	Overload		
	Enclosure for KWIKstarter ③ CAK7/CBK7-30...43 CAK7/CBK7-30E...43E	CA7-30...43 CA7-30E...43E	CEP7-ED1CD...ED1FD CEP7-EECD...EEFD CEP7S-EETD	cUL Type 1/12/4/4x IEC IP66	KS7-C2S4
	Enclosure for Reversing KWIKstarter ④ CAUK7-9...23 CAUK7-9E...23E	CAU7-9...23 CAU7-9E...23E	CEP7-ED1AB...ED1EB CEP7-EEAB...EEEB	cUL Type 1/12/4/4x IEC IP66	KS7-COS4R

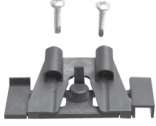

- ① KWIKstarters are only designed to accommodate CA7-9...43 contactors with CT7N Thermal Overload Relays or CEP7 Solid State Overload Relays. If ordering components, select contactor from Section A and overload relay from Section B in this catalog.
- ② KS7-COS4 and KS7-COS1 may be used with either CEP7 or CT7N (field interchangeable).
- ③ KWIKstarter enclosure KS7-C2S4 are designed to fit CA7-30(E)...43(E) contactors with CEP7 Overload Relays. CT7N Thermal Overloads can not be

- substituted.
- ④ KWIKstarter enclosure KS7-COS4R are designed to fit CAU7-9(E)...23(E) reversing contactors with CEP7 Overload Relays. CT7N Thermal Overloads can not be substituted.
- ⑤ KS7-C2S4 and KS7-COS4R are supplied with two 22mm holes for Pilot Devices. A Reset is required and one additional pilot device kit from page C101.13 must be selected. Use of a CPT is not possible.

KWIKstarter Components with CT7N or CEP7 Overload Relays (for use with KS7-COS1/KS7-COS4)

Component	Description	For Use With...	Catalog Number
	Start - Contact kit Specially designed NO auxiliary; mechanically interfaces with the START button. Mounts on right side. A KS7-PCK is included in every KS7-COS4 enclosure.	KS7-COS4 (Replacement Part)	KS7-PCK
	Pushbutton Latch - For maintain contact control (2-wire control)	KS7-COS4	KS7-PLA
	Neutral Terminal	KS7-COS1 KS7-COS4	KS7-PNT
	Grounding Kit (for use with metal conduit)	All KWIKstarter enclosures	KS7-GR1

KWIKstarter Pilot Device Kits (for use with KS7-C2S4/KS7-COS4R) ❶

Kits	Description	For Use With Enclosure...	Contact Blocks included		Catalog Number
			NO	NC	
	Multi-Function Pushbutton kit Non-illuminated START-STOP I-O	KS7-C2S4 Type 1, 12, 4, 4X	1	1	KS7-P3U KS7-P4U
	FOR-STOP-REV UP-STOP-DOWN OPEN-STOP-CLOSE	KS7-COS4R Type 1, 12, 4, 4X	2	1	KS7-P3U-REV KS7-P4U-REV KS7-P5U-REV
	Selector switch kits Non-illuminated, includes legend plate ON-OFF 2-Position	KS7-C2S4 Type 1, 12, 4, 4X	1	-	KS7-P6
	FOR-OFF-REV 3-Position UP-OFF-DOWN 3-Position OPEN-OFF-CLOSE 3-Position	KS7-COS4R Type 1, 12, 4, 4X	2	-	KS7-P6-REV KS7-P7-REV KS7-P8-REV
	Reset Pushbutton, Blue Plastic push button, flush operator with Blue Cap and R text	KS7-C2S4 KS7-COS4	Black Plastic with Blue Cap and White "R"		D7P-F611 ❷

❶ Plastic bezel is standard. Pilot Device Kits include D7-BX_ Base Mounted contact blocks. See page H69 for more information.

❷ D7P-R611 and CEP7-ERA can not be used with KS7-C2S4 or KS7-COS4R. See Section H for more information.

**KWIKstarters with CEP7 Solid State Overload Relay
3-Phase Application ②③**

For use with KWIKstarter...	Amp Range	Overload Relay Code (◆)	Catalog Number (of Overload Relay used)
3-Phase / Manual Reset / Class 10			
CAK7-9...CAK7-23	0.1...0.5	D1AB	CEP7-ED1AB
	0.2...1.0	D1BB	CEP7-ED1BB
	1.0...5.0	D1CB	CEP7-ED1CB
	3.2...16	D1DB	CEP7-ED1DB
	5.4...27	D1EB	CEP7-ED1EB
3-Phase / Selectable Function and Class			
CAK7-9...CAK7-23	0.1...0.5	EAB	CEP7-EEAB
	0.2...1.0	EBB	CEP7-EEBB
	1.0...5.0	ECB	CEP7-EECB
	3.2...16	EDB	CEP7-EEDB
	5.4...27	EEB	CEP7-EEEB

**KWIKstarters with CEP7 Solid State Overload Relay
1-Phase Application ②③**

For use with KWIKstarter...	Amp Range	Overload Relay Code (◆)	Catalog Number (of Overload Relay used)
1-Phase / Selectable Function and Class			
CBK7-9...CBK7-23	1.0-5.0	EPB	CEP7S-EEPB
	3.2-16	ERB	CEP7S-EERB
	5.4-27	ESB	CEP7S-EESB

**KWIKstarters with CT7N Bimetallic
Overload Relays ①**

For use with Kwikstarter...	Amp Range	Overload Relay Code (◆)	Catalog Number (of Overload Relay used)
CAK7-9...CAK7-23 and CBK7-9...CBK7-23 Frame "A"	0.10...0.16	AA16	CT7N-23-A16
	0.16...0.25	AA25	CT7N-23-A25
	0.25...0.40	AA40	CT7N-23-A40
	0.35...0.50	AA50	CT7N-23-A50
	0.45...0.63	AA63	CT7N-23-A63
	0.55...0.80	AA80	CT7N-23-A80
	0.75...1.0	AB10	CT7N-23-B10
	0.90...1.3	AB13	CT7N-23-B13
	1.1...1.6	AB16	CT7N-23-B16
	1.4...2.0	AB20	CT7N-23-B20
	1.8...2.5	AB25	CT7N-23-B25
	2.3...3.2	AB32	CT7N-23-B32
	2.9...4.0	AB40	CT7N-23-B40
	3.5...4.8	AB48	CT7N-23-B48
	4.5...6.3	AB63	CT7N-23-B63
	5.5...7.5	AB75	CT7N-23-B75
	7.2...10	AC10	CT7N-23-C10
	9.0...12.5	AC12	CT7N-23-C12
	11.3...16	AC16	CT7N-23-C16
	15...20	AC20	CT7N-23-C20
17.5...21.5	AC21	CT7N-23-C21	
21...25	AC25	CT7N-23-C25	

① If using CT7N in single phase application with CBKN7-9...23, wire per drawing on page C101.15.
 ② CEP7 Overloads are available for use in KWIKstarters if the premium features are required (see Section B).
 ③ 3-phase CEP7-ED or CEP7-EE units are only designed for 3∅ applications. Single phase CEP7S units are only designed for 1∅ applications. If using CEP7S, wire per drawing on page C101.15.

KWIKstarter (in enclosure KS7-COS1/COS4)

CUSTOMER MUST PROVIDE PROPER BRANCH CIRCUIT PROTECTION (F1)
SEE THE APPLICATION INSTRUCTION SHEET - COMPONENT SELECTION TABLES
FOR MAX. FUSE SIZE & CLASS AND APPLICABLE SHORT CIRCUIT RATING
(USE 75°C COPPER WIRE ONLY)

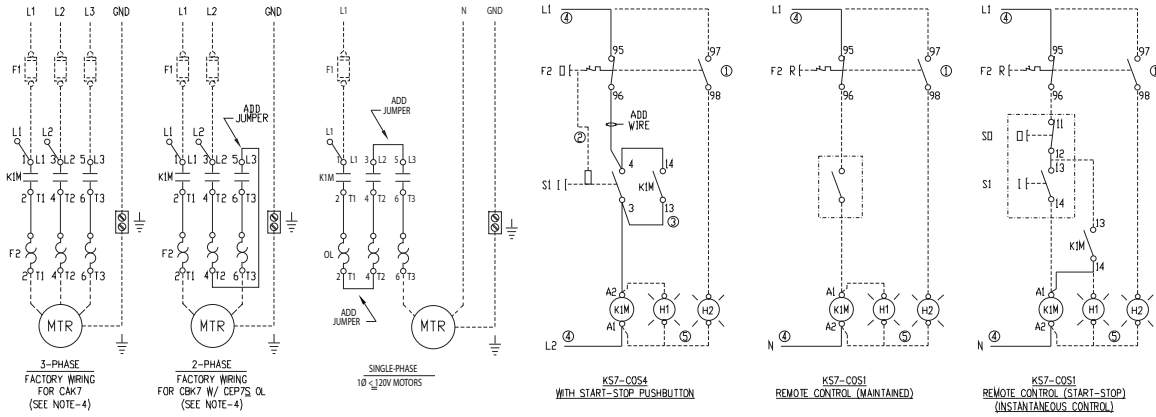

THIS DRAWING IS FOR THE FOLLOWING ENCLOSURES:
KS7-COS4 with integrated START-STOP push buttons
KS7-COS1 with integrated RESET push button

NOTES:

- 1) MECHANICAL LATCH KS7-PLA FOR MAINTAINED CONTROL (OPTIONAL).
- 2) START CONTACT KIT KS7-PCK (INCLUDED) MOUNTS ON THE RIGHT SIDE WITH MOLDED PRE-FORMED JUMPERS.
- 3) DO NOT WIRE CONTROLS CIRCUIT TO LINE SIDE OF CONTACTOR WHEN COIL VOLTAGE IS 120V OR LESS. (FACTORY WIRING STANDARD)
- 4) OPTIONAL PILOT LIGHTS.

KWIKstarter (in enclosure KS7-C2S4)

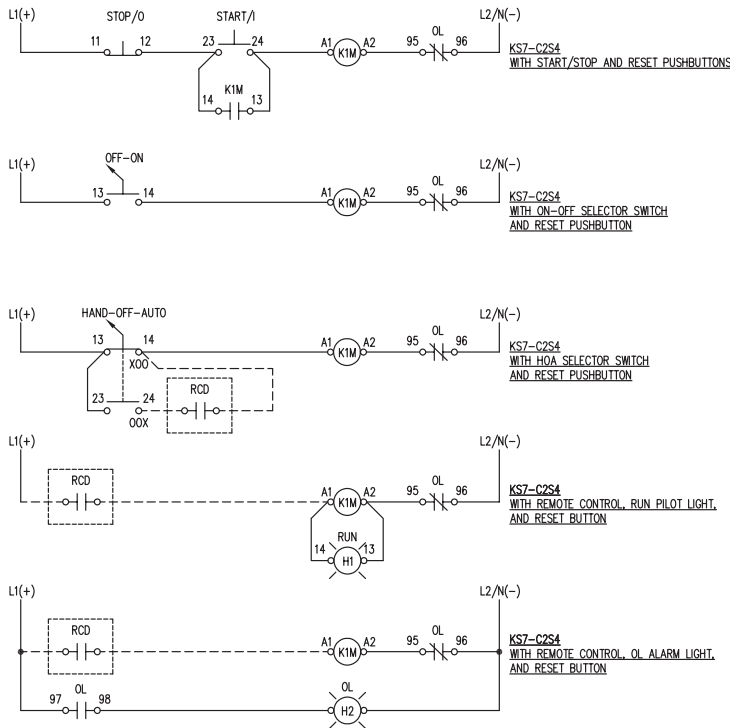

CUSTOMER WILL PROVIDE BRANCH CIRCUIT PROTECTION (F1)
SEE THE APPLICATION INSTRUCTION SHEET - COMPONENT SELECTION TABLES
FOR MAX. FUSE SIZE, CLASS, AND APPLICABLE SHORT CIRCUIT RATING
(USE 75°C COPPER WIRE ONLY)

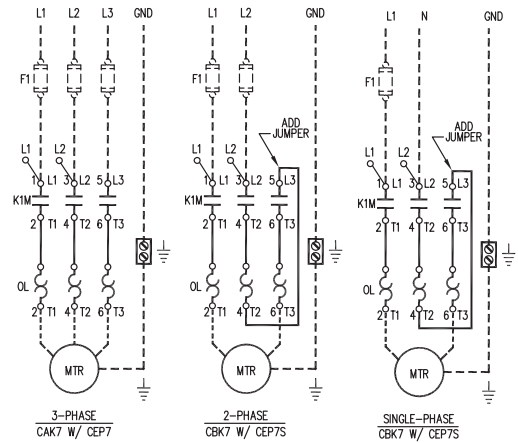

NOTES:

1. DO NOT CONNECT A1-A2 TO L1-L2 UNLESS COIL VOLTAGE MATCHES LINE VOLTAGE
2. PILOT LIGHTS POSSIBLE FOR REMOTE OR OVERLOAD ALARM IF NO START/STOP CONTROL DEVICES IN COVER
3. RCD = REMOTE CONTROL DEVICE (BY OTHERS)

Reversing KWIKstarter (in enclosure KS7-C0S4R)

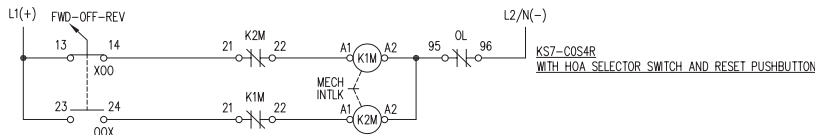
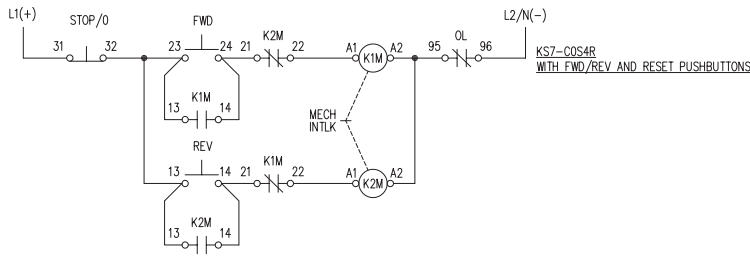

NOTE:
DO NOT CONNECT A1-A2 TO L1-L2 UNLESS COIL VOLTAGE MATCHES LINE VOLTAGE

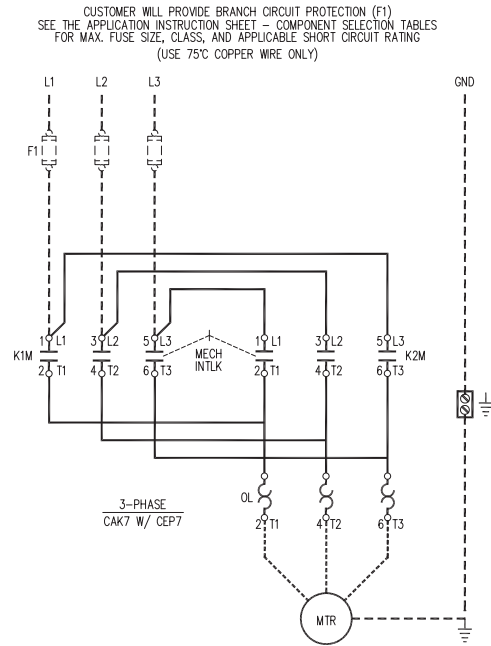

KWIKstarter (in enclosure KS7-C0S1) with HOA option

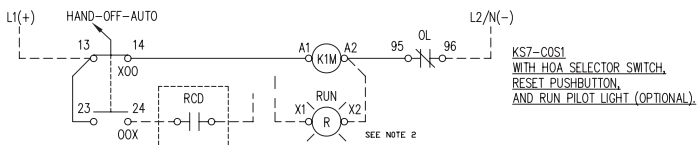
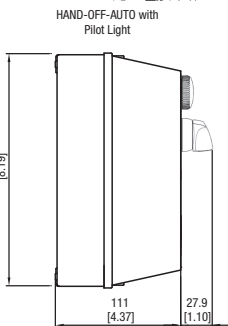

CUSTOMER WILL PROVIDE BRANCH CIRCUIT PROTECTION (F1)
SEE THE APPLICATION INSTRUCTION SHEET - COMPONENT SELECTION TABLES
FOR MAX. FUSE SIZE, CLASS, AND APPLICABLE SHORT CIRCUIT RATING
(USE 75°C COPPER WIRE ONLY)

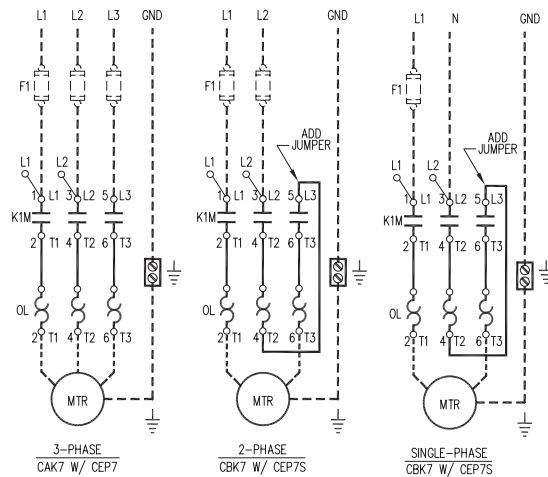

NOTES:

- RCD = REMOTE CONTROL DEVICE (BY OTHERS). WIRE RCD TO TERMINAL 24 ON THE H-O-A SEL. SW. AND TERMINAL A1 ON THE CONTACTOR.
- DASHED LINES - - - - - INDICATE WIRING PROVIDED IN THE FIELD.

A.C. Coil Code	Voltage Range		Control Source	
	50 Hz	60 Hz	CBK7	CAK7
24Z	24V	24V	Separate	Separate
120	110V	120V	Common	Separate
208	~	208V	Common	Common
220W	200V-220V	208V-240V	Common	Common
240	220V	240V	Common	Common
D.C. Coil Code	Voltage Range		Control Source	
	VDC		CBK7	CAK7
12E	12V		Separate	Separate
24E	24V		Separate	Separate

KWIKstarter Enclosure KS7-C0S1/C0S4 (Dimension Code Q1-Q3)

Dimensions are in millimeters (inches). Dimensions not intended for manufacturing purposes.

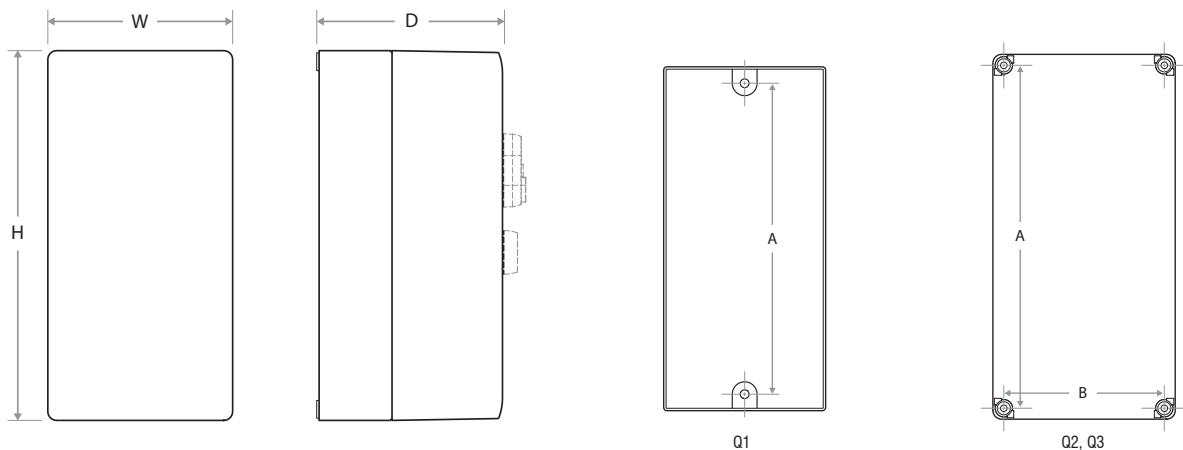

Enclosure Size

DIM Code	W	H	D
Q1	97 [3.86]	205 [8.08]	111 [4.37]
Q2, Q3	125 [4.93]	250 [9.85]	125 [4.93]

Provision for Cable Gland Fittings

DIM Code	ØTop	ØBack
Q1	2 X 20.3 [0.80] or 25.3 [1.00]	4 X 20.3 [0.80] or 25.3 [1.00]
Q2, Q3	2 X 20.3 [0.80] or 25.3 [1.00]	~

Mounting

DIM Code	Mount Type	ØA	ØB	Dia.
Q1	2 Center screws	188 [7.4]	Centered	5.3 [0.2]
Q2, Q3	4 Corner screws	235 [9.26]	110 [4.33]	5.3 [0.2]

NEMA Sized Open and Enclosed Non-Combination Motor Starters

C
NEMA Starters

Built to your specifications and ready to install

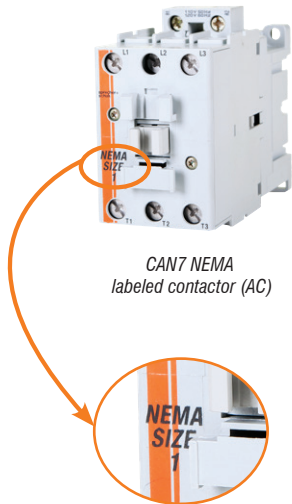

CAN7 NEMA labeled contactor (AC)

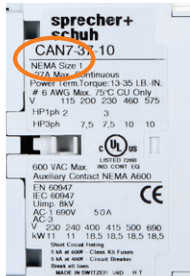

Sprecher + Schuh magnetic motor starters are intended to eliminate the purchase and assembly of a separate contactor, overload relay and associated wiring. When purchased with an enclosure, the starters are mounted and ready to install on receipt.

Starting with the best

At the heart of all Sprecher + Schuh NEMA sized magnetic motor starters is the CATN7 line of motor starters. Each starter proudly displays the NEMA size (00, 0, 1, 2, or 3) and HP at applied voltage. This line of starters is designed to meet rigid consultant specifications for NEMA starters.

Top line protection...

NEMA labeled magnetic starters are equipped with Sprecher + Schuh's premium CEP7 solid state overload relay standard. Unlike traditional overload relays that indirectly sense motor current through heater elements, CEP7 solid state overload relays measure motor current directly through integrated current transformers and on board electronics. The electronics provide numerous advantages over electromechanical relays. Alternatively, the CT7N Thermal Overload Relay may also be selected.

The right enclosure... whatever the application

Sprecher + Schuh's line of NEMA style starters can be purchased pre-installed in a variety of standard enclosures.

Cataloged enclosures include:

- | | |
|----------------|---------------------------------|
| Type 1 | General Purpose |
| Type 12 | Industrial Dusttight |
| Type 3R | Raintight (outdoor) |
| Type 4 | Watertight |
| Type 4X | Watertight, Corrosion Resistant |



Type 1



Type 3R



Type 4



Type 4X

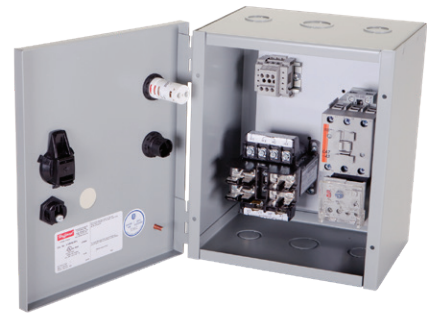

Even though these are the most popular enclosure types for most industrial applications, we can house any starter in a custom enclosure of your choosing.

Quality enclosures ensure the highest confidence

Sprecher + Schuh only sources enclosures from name brand manufacturers, ensuring the highest quality. We primarily use enclosures that meet UL Standards, i.e., Type 1, Type 3R, etc., however, we can also source other enclosures at your request. Enclosures are sized first to accommodate the depth of the contactor and offer sufficient electrical clearances to satisfy UL.

Add a variety of modifications

If you need a larger enclosure than what is specified in our catalog, your sales representative and our Engineering department will work with you to customize any of our enclosed products to suit your exact specifications. Any combination of enclosure types, sizes, pilot devices, meters and other modifications can be combined to provide exactly the panel you need.

Three Phase, Non-Reversing CATN7

NEMA Size	Maximum Horsepower Three Phase				Aux. Contacts per Contactor ③		Open Type Catalog Number	Type 1 General Purpose Catalog Number	D I M ① Catalog Number	Type 12 [Type 3R ②] Industrial Dusttight Catalog Number	D I M ①
	200V	230V	460V	575V	NO	NC					
00	1.5	1.5	2	2	1	0	CATN7-12-*◆	CATN7-12-*◆-GO	A	CATN7-12-*◆-D0	L
0	3	3	5	5	1	0	CATN7-16-*◆	CATN7-16-*◆-GO	A	CATN7-16-*◆-D0	L
1	7.5	7.5	10	10	1	0	CATN7-37-*◆	CATN7-37-*◆-GO	A	CATN7-37-*◆-D0	L
2	10	15	25	25	1	0	CATN7-43-*◆	CATN7-43-*◆-GO	A	CATN7-43-*◆-D0	L
3	25	30	50	50	1	0	CATN7-85-*◆	CATN7-85-*◆-GO	B	CATN7-85-*◆-D0	M

NEMA Size	Maximum Horsepower Three Phase				Aux. Contacts per Contactor ③		Type 4 Watertight Catalog Number	D I M ① Catalog Number	Type 4X Watertight Corrosion Resistant Non-metallic Catalog Number	D I M ①
	200V	230V	460V	575V	NO	NC				
00	1.5	1.5	2	2	1	0	CATN7-12-*◆-WO	N CATN7-12-*◆-CO	S1	
0	3	3	5	5	1	0	CATN7-16-*◆-WO	N CATN7-16-*◆-CO	S1	
1	7.5	7.5	10	10	1	0	CATN7-37-*◆-WO	N CATN7-37-*◆-CO	U1	
2	10	15	25	25	1	0	CATN7-43-*◆-WO	N CATN7-43-*◆-CO	U1	
3	25	30	50	50	1	0	CATN7-85-*◆-WO	O CATN7-85-*◆-CO	U1	

NOTE: Catalog numbers and enclosure dimensions reflect contactors with AC coils. For DC coils, select Coil Code from the DC Coil Code table on page C104 and follow the instructions for modifying catalog numbers.

Ordering Instructions

Specify Catalog Number	
Replace (*) with Coil Code	See page C104 See pages C105-C106 See pages C107-C111
Replace (◆) with O/L Relay	
Factory Modifications available	

- ① Dimensional information starts on page C122.
- ② For Type 3R outdoor applications, replace "D" in catalog number with an "R". Dimensions may change. For example number CATN7-37-*◆-D0 becomes CATN7-37-*◆-R0. Price remains the same.
- ③ Contactors are equipped with number and type of auxiliaries indicated. See page C108 to order additional or different auxiliary contacts.

Three Phase, Non-Reversing CATN7 @208V AC ②

NEMA Size	Max HP 3-Phase ①	Adjustment Range	Type 1 Metallic General Purpose	D I M	Type 3R Metallic Outdoor Raintight	D I M
			Catalog Number		③ Catalog Number	
00	1.5	0.2...1.0	CATN7-12-XA-1EBB-G17-L11	A	CATN7-12-XA-1EBB-R17-L11	L
	3	1.0...5.0	CATN7-12-XA-1ECB-G17-L11	A	CATN7-12-XA-1ECB-R17-L11	L
	7.5	1.0...5.0	CATN7-12-XA-1ECB-G17-L11	A	CATN7-12-XA-1ECB-R17-L11	L
	10	1.0...5.0	CATN7-12-XA-1ECB-G17-L11	A	CATN7-12-XA-1ECB-R17-L11	L
	25	3.2...16	CATN7-12-XA-1EDB-G17-L11	A	CATN7-12-XA-1EDB-R17-L11	L
0	2	3.2...16	CATN7-16-XA-1EDB-G17-L11	A	CATN7-16-XA-1EDB-R17-L11	L
	3	3.2...16	CATN7-16-XA-1EDB-G17-L11	A	CATN7-16-XA-1EDB-R17-L11	L
1	5	5.4...27	CATN7-37-XA-1EED-G17-L11	A	CATN7-37-XA-1EED-R17-L11	L
	7.5	5.4...27	CATN7-37-XA-1EED-G17-L11	A	CATN7-37-XA-1EED-R17-L11	L
2	10	11...55	CATN7-43-XA-1EFD-G17-L11	A	CATN7-43-XA-1EFD-R17-L11	L
3	15	20...100	CATN7-85-XA-1EGE-G17-L11	B	CATN7-85-XA-1EGE-R17-L11	M
	20	20...100	CATN7-85-XA-1EGE-G17-L11	B	CATN7-85-XA-1EGE-R17-L11	M
	25	20...100	CATN7-85-XA-1EGE-G17-L11	B	CATN7-85-XA-1EGE-R17-L11	M

Full Voltage Non-Reversing (FVNR) Features include:

- NEMA-sized CAN7 contactor
- CEP7 Electronic Overload Relay
- Control Circuit Transformer
- Hand-Off-Auto (H-O-A) selector switch
- Red Run pilot light
- 2-NO and 1-NC auxiliaries for customer use
- Class CC Fuse holder as fused primary of CCT
- Reset pushbutton

Three Phase, Non-Reversing CATN7 @230V AC ②

NEMA Size	Max HP 3-Phase ①	Adjustment Range	Type 1 Metallic General Purpose	D I M	Type 3R Metallic Outdoor Raintight	D I M
			Catalog Number		③ Catalog Number	
00	0.25	0.2...1.0	CATN7-12-XB-1EBB-G17-L11	A	CATN7-12-XB-1EBB-R17-L11	L
	0.5	1.0...5.0	CATN7-12-XB-1ECB-G17-L11	A	CATN7-12-XB-1ECB-R17-L11	L
	0.75	1.0...5.0	CATN7-12-XB-1ECB-G17-L11	A	CATN7-12-XB-1ECB-R17-L11	L
	1	1.0...5.0	CATN7-12-XB-1ECB-G17-L11	A	CATN7-12-XB-1ECB-R17-L11	L
	1.5	1.0...5.0	CATN7-12-XB-1ECB-G17-L11	A	CATN7-12-XB-1ECB-R17-L11	L
0	2	3.2...16	CATN7-16-XB-1EDB-G17-L11	A	CATN7-16-XB-1EDB-R17-L11	L
	3	3.2...16	CATN7-16-XB-1EDB-G17-L11	A	CATN7-16-XB-1EDB-R17-L11	L
1	5	5.4...27	CATN7-37-XB-1EED-G17-L11	A	CATN7-37-XB-1EED-R17-L11	L
	7.5	5.4...27	CATN7-37-XB-1EED-G17-L11	A	CATN7-37-XB-1EED-R17-L11	L
2	10	11...55	CATN7-43-XB-1EFD-G17-L11	A	CATN7-43-XB-1EFD-R17-L11	L
	15	11...55	CATN7-43-XB-1EFD-G17-L11	A	CATN7-43-XB-1EFD-R17-L11	L
3	15	20...100	CATN7-85-XB-1EGE-G17-L11	B	CATN7-85-XB-1EGE-R17-L11	M
	20	20...100	CATN7-85-XB-1EGE-G17-L11	B	CATN7-85-XB-1EGE-R17-L11	M
	25	20...100	CATN7-85-XB-1EGE-G17-L11	B	CATN7-85-XB-1EGE-R17-L11	M

Full Voltage Non-Reversing (FVNR) Features include:

- NEMA-sized CAN7 contactor
- CEP7 Electronic Overload Relay
- Control Circuit Transformer
- Hand-Off-Auto (H-O-A) selector switch
- Red Run pilot light
- 2-NO and 1-NC auxiliaries for customer use
- Class CC Fuse holder as fused primary of CCT
- Reset pushbutton

- ① HP and NEMA size selection for line voltages shown. Contact your Sprecher + Schuh representative for other voltage application.
- ② Contactors are equipped with 2 NO and 1 NC auxiliary contact. See page C108 to order additional or different auxiliary contacts.
- ③ Dimensional information starts on page C122.

Three Phase, Non-Reversing CATN7 @460V AC ②

NEMA Size	Max HP 1-Phase ①	Adjustment Range	Type 1 Metallic General Purpose	D I M	Type 3R Metallic Outdoor Raintight	D I M
	460V		Catalog Number		③ Catalog Number	
00	0.25	0.2...1.0	CATN7-12-XC-1EBB-G17-L11	A	CATN7-12-XA-1EBB-R17-L11	L
	0.5	1.0...5.0	CATN7-12-XC-1ECB-G17-L11	A	CATN7-12-XC-1ECB-R17-L11	L
	0.75	1.0...5.0	CATN7-12-XC-1ECB-G17-L11	A	CATN7-12-XC-1ECB-R17-L11	L
	1	1.0...5.0	CATN7-12-XC-1ECB-G17-L11	A	CATN7-12-XC-1ECB-R17-L11	L
	1.5	1.0...5.0	CATN7-12-XC-1ECB-G17-L11	A	CATN7-12-XC-1ECB-R17-L11	L
	2	1.0...5.0	CATN7-12-XC-1ECB-G17-L11	A	CATN7-12-XC-1ECB-R17-L11	L
0	3	3.2...16	CATN7-16-XC-1EDB-G17-L11	A	CATN7-16-XC-1EDB-R17-L11	L
	5	3.2...16	CATN7-16-XC-1EDB-G17-L11	A	CATN7-16-XC-1EDB-R17-L11	L
1	7.5	5.4...27	CATN7-37-XC-1EED-G17-L11	A	CATN7-37-XC-1EED-R17-L11	L
	10	5.4...27	CATN7-37-XC-1EED-G17-L11	A	CATN7-37-XC-1EED-R17-L11	L
2	15	11...55	CATN7-43-XC-1EFD-G17-L11	A	CATN7-43-XC-1EFD-R17-L11	L
	20	11...55	CATN7-43-XC-1EFD-G17-L11	A	CATN7-43-XC-1EFD-R17-L11	L
	25	11...55	CATN7-43-XC-1EFD-G17-L11	A	CATN7-43-XC-1EFD-R17-L11	L
3	30	20...100	CATN7-85-XC-1EGE-G17-L11	B	CATN7-85-XC-1EGE-R17-L11	M
	40	20...100	CATN7-85-XC-1EGE-G17-L11	B	CATN7-85-XC-1EGE-R17-L11	M
	50	20...100	CATN7-85-XC-1EGE-G17-L11	B	CATN7-85-XC-1EGE-R17-L11	M

Full Voltage Non-Reversing (FVNR) Features include:

- NEMA-sized CAN7 contactor
- CEP7 Electronic Overload Relay
- Control Circuit Transformer
- Hand-Off-Auto (H-O-A) selector switch
- Red Run pilot light
- 2-NO and 1-NC auxiliaries for customer use
- Class CC Fuse holder as fused primary of CCT
- Reset pushbutton

Three Phase, Non-Reversing CATN7 @575V AC ②

NEMA Size	Max HP 3-Phase ①	Adjustment Range	Type 1 Metallic General Purpose	D I M	Type 3R Metallic Outdoor Raintight	D I M
	575V		Catalog Number		③ Catalog Number	
00	0.25	0.2...1.0	CATN7-12-XD-1EBB-G17-L11	A	CATN7-12-XD-1EBB-R17-L11	L
	0.5	1.0...5.0	CATN7-12-XD-1ECB-G17-L11	A	CATN7-12-XD-1ECB-R17-L11	L
	0.75	1.0...5.0	CATN7-12-XD-1ECB-G17-L11	A	CATN7-12-XD-1ECB-R17-L11	L
	1	1.0...5.0	CATN7-12-XD-1ECB-G17-L11	A	CATN7-12-XD-1ECB-R17-L11	L
	2	1.0...5.0	CATN7-12-XD-1ECB-G17-L11	A	CATN7-12-XD-1ECB-R17-L11	L
	0	3	3.2...16	CATN7-16-XD-1EDB-G17-L11	A	CATN7-16-XD-1EDB-R17-L11
5		3.2...16	CATN7-16-XD-1EDB-G17-L11	A	CATN7-16-XD-1EDB-R17-L11	L
1	7.5	5.4...27	CATN7-37-XD-1EED-G17-L11	A	CATN7-37-XD-1EED-R17-L11	L
	10	5.4...27	CATN7-37-XD-1EED-G17-L11	A	CATN7-37-XD-1EED-R17-L11	L
2	15	11...55	CATN7-43-XD-1EFD-G17-L11	A	CATN7-43-XD-1EFD-R17-L11	L
	20	11...55	CATN7-43-XD-1EFD-G17-L11	A	CATN7-43-XD-1EFD-R17-L11	L
	25	11...55	CATN7-43-XD-1EFD-G17-L11	A	CATN7-43-XD-1EFD-R17-L11	L
3	30	20...100	CATN7-85-XD-1EGE-G17-L11	B	CATN7-85-XD-1EGE-R17-L11	M
	40	20...100	CATN7-85-XD-1EGE-G17-L11	B	CATN7-85-XD-1EGE-R17-L11	M
	50	20...100	CATN7-85-XD-1EGE-G17-L11	B	CATN7-85-XD-1EGE-R17-L11	M

Full Voltage Non-Reversing (FVNR) Features include:

- NEMA-sized CAN7 contactor
- CEP7 Electronic Overload Relay
- Control Circuit Transformer
- Hand-Off-Auto (H-O-A) selector switch
- Red Run pilot light
- 2-NO and 1-NC auxiliaries for customer use
- Class CC Fuse holder as fused primary of CCT
- Reset pushbutton

① HP and NEMA size selection for line voltages shown. Contact your Sprecher + Schuh representative for other voltage application.
 ② Contactors are equipped with 2 NO and 1 NC auxiliary contact. See page C108 to order additional or different auxiliary contacts.
 ③ Dimensional information starts on page C122.

Single Phase, Non-Reversing CBTN7

NEMA Size	Maximum HP Single ϕ		Aux. Contacts per Contactor ①		Open Type	Type 1 General Purpose	D I M	Type 12 [Type 3R ②] Industrial Dusttight	D I M
	115V	230V	NO	NC					
00	.33	1	1	0	CBTN7-12-* \blacklozenge	CBTN7-12-* \blacklozenge -G0	A	CBTN7-12-* \blacklozenge -D0	L
0	1	2	1	0	CBTN7-16-* \blacklozenge	CBTN7-16-* \blacklozenge -G0	A	CBTN7-16-* \blacklozenge -D0	L
1	2	3	1	0	CBTN7-37-* \blacklozenge	CBTN7-37-* \blacklozenge -G0	A	CBTN7-37-* \blacklozenge -D0	L
2	3	7.5	1	0	CBTN7-43-* \blacklozenge	CBTN7-43-* \blacklozenge -G0	A	CBTN7-43-* \blacklozenge -D0	L
3	7.5	15	1	0	CBTN7-85-* \blacklozenge	CBTN7-85-* \blacklozenge -G0	B	CBTN7-85-* \blacklozenge -D0	M

Single Phase, Non-Reversing CBTN7

NEMA Size	Maximum HP Single ϕ		Aux. Contacts per Contactor ①		Type 4 Watertight	D I M	Type 4X Watertight Corrosion Resistant Non-metallic	D I M
	115V	230V	NO	NC				
00	.33	1	1	0	CBTN7-12-* \blacklozenge -W0	N	CBTN7-12-* \blacklozenge -C0	S1
0	1	2	1	0	CBTN7-16-* \blacklozenge -W0	N	CBTN7-16-* \blacklozenge -C0	S1
1	2	3	1	0	CBTN7-37-* \blacklozenge -W0	N	CBTN7-37-* \blacklozenge -C0	U1
2	3	7.5	1	0	CBTN7-43-* \blacklozenge -W0	N	CBTN7-43-* \blacklozenge -C0	U1
3	7.5	15	1	0	CBTN7-85-* \blacklozenge -W0	O	CBTN7-85-* \blacklozenge -C0	U1

NOTE: Catalog numbers and enclosure dimensions reflect contactors with AC coils. For DC coils, select Coil Code from the DC Coil Code table on page C104 and follow the instructions for modifying catalog numbers.

Ordering Instructions

Specify Catalog Number	
Replace (*) with Coil Code	See page C104 See pages C105-C106 See pages C107-C111
Replace \blacklozenge with O/L Relay	
Factory Modifications available	

- ① Contactors are equipped with number and type of auxiliaries indicated. See page C108 to order additional or different auxiliary contacts.
- ② For Type 3R outdoor applications, replace "D" in catalog number with an "R". Dimensions may change. For example number CBTN7-37-* \blacklozenge -D0 becomes CBTN7-37-* \blacklozenge -R0.
- ③ Dimensional information starts on page C122.

Non-Reversing , Non-Reversing CBTN7 @115V AC ②

NEMA Size	Max HP 1-Phase ①	Adjustment Range	Type 1 Metallic General Purpose	D I M	Type 3R Metallic Outdoor Raintight	D I M
	115V		Catalog Number		③ Catalog Number	
00	0.33	3.2...16	CBTN7-12-120-1EDB-G17-L11	A	CBTN7-12-120-1EDB-R17-L11	L
0	0.5	5.4...27	CBTN7-16-120-1EEB-G17-L11	A	CBTN7-16-120-1EEB-R17-L11	L
	0.75	5.4...27	CBTN7-16-120-1EEB-G17-L11	A	CBTN7-16-120-1EEB-R17-L11	L
	1	5.4...27	CBTN7-16-120-1EEB-G17-L11	A	CBTN7-16-120-1EEB-R17-L11	L
1	1.5	11...55	CBTN7-37-120-1EFD-G17-L11	A	CBTN7-37-120-1EFD-R17-L11	L
	2	11...55	CBTN7-37-120-1EFD-G17-L11	A	CBTN7-37-120-1EFD-R17-L11	L
2	3	11...55	CBTN7-43-120-1EFD-G17-L11	A	CBTN7-43-120-1EFD-R17-L11	L
3	5	20...100	CBTN7-85-120-1EGE-G17-L11	B	CBTN7-85-120-1EGE-R17-L11	M
	7.5	20...100	CBTN7-85-120-1EGE-G17-L11	B	CBTN7-85-120-1EGE-R17-L11	M

Full Voltage Non-Reversing (FVNR) Features include:

- NEMA-sized CAN7 contactor
- CEP7 Electronic Overload Relay
- Control Circuit Transformer
- Hand-Off-Auto (H-O-A) selector switch
- Red Run pilot light
- 2-NO and 1-NC auxiliaries for customer use
- Class CC Fuse holder as fused primary of CCT
- Reset pushbutton

Single Phase, Non-Reversing CBTN7 @230V AC ②

NEMA Size	Max HP 1-Phase ①	Adjustment Range	Type 1 Metallic General Purpose	D I M	Type 3R Metallic Outdoor Raintight	D I M
	230V		Catalog Number		③ Catalog Number	
00	0.25	1.0...5.0	CBTN7-12-220W-1ECB-G17-L11	A	CBTN7-12-220W-1ECB-R17-L11	L
	0.5	1.0...5.0	CBTN7-12-220W-1ECB-G17-L11	A	CBTN7-12-220W-1EDB-R17-L11	L
	0.75	3.2...16	CBTN7-12-220W-1EDB-G17-L11	A	CBTN7-12-220W-1EDB-R17-L11	L
	1	3.2...16	CBTN7-12-220W-1EDB-G17-L11	A	CBTN7-12-220W-1EDB-R17-L11	L
0	1.5	5.4...27	CBTN7-16-220W-1EEB-G17-L11	A	CBTN7-16-220W-1EEB-R17-L11	L
	2	5.4...27	CBTN7-16-220W-1EEB-G17-L11	A	CBTN7-16-220W-1EEB-R17-L11	L
1	3	11...55	CBTN7-37-220W-1EFD-G17-L11	A	CBTN7-37-220W-1EFD-R17-L11	L
2	5	11...55	CBTN7-43-220W-1EFD-G17-L11	A	CBTN7-43-220W-1EFD-R17-L11	L
	7.5	11...55	CBTN7-43-220W-1EFD-G17-L11	A	CBTN7-43-220W-1EFD-R17-L11	L
3	10	20...100	CBTN7-85-220W-1EGE-G17-L11	B	CBTN7-85-220W-1EGE-R17-L11	M
	15	20...100	CBTN7-85-220W-1EGE-G17-L11	B	CBTN7-85-220W-1EGE-R17-L11	M

- ① HP and NEMA size selection for line voltages shown. Contact your Sprecher + Schuh representative for other voltage application.
- ② Contactors are equipped with 2 NO and 1 NC Auxiliary contacts. See page C108 to order additional or different auxiliary contacts.
- ③ Dimensional information starts on page C122.

NEMA Sized Combination Starters - Through the Door Operated

C
NEMA Starters

Smart and cost effective... for any application



CAN7 NEMA labeled contactor (AC)

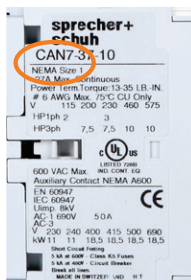

Sprecher + Schuh's through-the-door operated combination starters represent an economical alternative to the classic flange-operated combo solution. It is designed to meet rigid UL/NEC withstand specifications. Sprecher + Schuh has been building custom control panels with this design for years. Experience the durability of this product!



Thermal Magnetic Molded Case Circuit Breaker (MCCB)

The through-the-door operated combo MCCB is available to meet UL short circuit withstand specifications. An MCCB prevents single phasing by simultaneously opening all three phases when a fault occurs in any one phase. An MCCB can often be reset after the fault has been cleared.

Disconnect Switches

The through-the-door operated combo is available with the L11 switch. A mechanical door interlock system prevents the door from being opened when the disconnect is closed, and conversely, prevents the disconnect from being closed when the door is open. Both functions can be defeated for test and maintenance purposes. Other safety features include padlock provisions and a high visibility operating handle.

The L11 Switch disconnects have a quick make/quick break, non-teasing action. The L11 fusible switch is suitable for interrupting up to 100,000 amperes when class "J" fuses are used. All L11 disconnect switches conform to UL 98 standards.

Starting with the best

At the heart of all Sprecher + Schuh NEMA sized combination starters is the CATN7 line of motor starters. Each starter proudly displays the NEMA size (00, 0, 1, 2, or 3) and HP at applied voltage. This line of starters is designed to meet rigid consultant specifications for NEMA starters.

Top line protection...

NEMA labeled combination starters are equipped with Sprecher + Schuh's premium CEP7 solid state overload relay standard. Unlike traditional overload relays that indirectly sense motor current through heater elements, CEP7 solid state overload relays measure motor current directly through integrated current transformers and on board electronics. The electronics provide numerous advantages over electromechanical relays. Alternatively, the CT7N Thermal Overload Relay may also be selected.

Choice of Disconnect

- Choices for disconnect include:
- Thermal Magnetic Molded Case Circuit Breaker (MCCB)
- L11 Fusible or Non-Fusible Disconnect switch

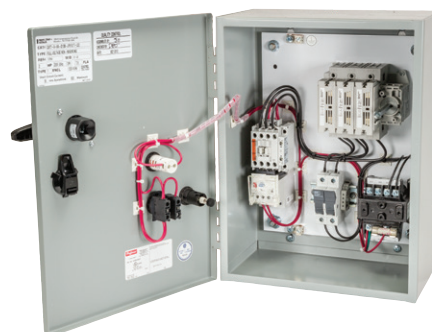

Choice of Enclosures

- Available enclosures include;
- Type 1 General Purpose
- Type 3R Raintight
- Type 12 Dusttight
- Type 4 Watertight
- Type 4X Corrosion Resistant

Series CATN7 with Thermal-Magnetic Circuit Breaker

NEMA Size	Maximum Horsepower Three Phase				MCCB Amps	Type 1 General Purpose	D I M	Type 12 [Type 3R Ⓣ] Industrial Dusttight	D I M	Type 4 Watertight	D I M	Type 4X Watertight Corrosion Resistant Non-metallic	D I M
	200V	230V	460V	575V		Catalog No.		Ⓣ Catalog No.		Ⓣ Catalog No.		Ⓣ Catalog No.	
						CATN		CATN		CATN		CATN	
00	1.5	1.5	2	2 Ⓣ	15	7-12-*◆-TB15G0	C2	7-12-*◆-TB15D0	C3	7-12-*◆-TB15W0	C2	7-12-*◆-TB15C0	V2
	2	2	5	5 Ⓣ	15	7-16-*◆-TB15G0	C2	7-16-*◆-TB15D0	C3	7-16-*◆-TB15W0	C2	7-16-*◆-TB15C0	V2
	3	3	~	~	20	7-16-*◆-TB20G0	C2	7-16-*◆-TB20D0	C3	7-16-*◆-TB20W0	C2	7-16-*◆-TB20C0	V2
1	~	~	7.5	10 Ⓣ	20	7-37-*◆-TB20G0	C2	7-37-*◆-TB20D0	C3	7-37-*◆-TB20W0	C2	7-37-*◆-TB20C0	V2
	~	5	10	~	30	7-37-*◆-TB30G0	C2	7-37-*◆-TB30D0	C3	7-37-*◆-TB30W0	C2	7-37-*◆-TB30C0	V2
	5	~	~	~	35	7-37-*◆-TB35G0	C2	7-37-*◆-TB35D0	C3	7-37-*◆-TB35W0	C2	7-37-*◆-TB35C0	V2
	~	7.5	~	~	40	7-37-*◆-TB40G0	C2	7-37-*◆-TB40D0	C3	7-37-*◆-TB40W0	C2	7-37-*◆-TB40C0	V2
	7.5	~	~	~	50	7-37-*◆-TB50G0	C2	7-37-*◆-TB50D0	C3	7-37-*◆-TB50W0	C2	7-37-*◆-TB50C0	V2
2	~	~	~	15 Ⓣ	35	7-43-*◆-TB35G0	C2	7-43-*◆-TB35D0	C3	7-43-*◆-TB35W0	C2	7-43-*◆-TB35C0	V2
	~	~	15	20 Ⓣ	40	7-43-*◆-TB40G0	C2	7-43-*◆-TB40D0	C3	7-43-*◆-TB40W0	C2	7-43-*◆-TB40C0	V2
	~	10	20	25 Ⓣ	50	7-43-*◆-TB50G0	C2	7-43-*◆-TB50D0	C3	7-43-*◆-TB50W0	C2	7-43-*◆-TB50C0	V2
	10	~	25	~	60	7-43-*◆-TB60G0	C2	7-43-*◆-TB60D0	C3	7-43-*◆-TB60W0	C2	7-43-*◆-TB60C0	V2
	~	15	~	~	80	7-43-*◆-TB80G0	C2	7-43-*◆-TB80D0	C3	7-43-*◆-TB80W0	C2	7-43-*◆-TB80C0	V2
3	~	~	~	30 Ⓣ	60	7-85-*◆-TB60G0	D3	7-85-*◆-TB60D0	Q	7-85-*◆-TB60W0	Q	7-85-*◆-TB60C0	W2
	~	~	30	40 Ⓣ	80	7-85-*◆-TB80G0	D3	7-85-*◆-TB80D0	Q	7-85-*◆-TB80W0	Q	7-85-*◆-TB80C0	W2
	15	20	40	50 Ⓣ	100	7-85-*◆-TB100G0	D3	7-85-*◆-TB100D0	Q	7-85-*◆-TB100W0	Q	7-85-*◆-TB100C0	W2
	25	30	50	~	125	7-85-*◆-TB125G0	D3	7-85-*◆-TB125D0	Q	7-85-*◆-TB125W0	Q	7-85-*◆-TB125C0	W2

NEMA Starters

NOTE: Catalog numbers and enclosure dimensions reflect contactors with AC coils. For DC coils, select Coil Code from the DC Coil Code table on page C104 and follow the instructions for modifying catalog numbers.

Ordering Instructions

Specify Catalog Number	
Replace (*) with Coil Code	See page C104
Replace (◆) with O/L Relay	See pages C105-C106
Factory Modifications available	See pages C107-C111

- Ⓣ Dimensional information starts on page C122.
- Ⓣ For Type 3R outdoor applications, replace "D" in catalog number with an "R". Dimensions may change. For example number CATN7-37-*◆-TB40D0 becomes CATN7-37-*◆-TB40R0.
- Ⓣ Applicable to 600Y/347V only. Refer to next page for 600V Delta solution.

Series CATN7 with Thermal-Magnetic Circuit Breaker - 600V Delta

NEMA Size	Maximum Horsepower Three Phase				MCCB Amps	Type 1 General Purpose	D I M	Type 12 [Type 3R ☉] Industrial Dusttight	D I M	Type 4 Watertight	D I M	Type 4X Watertight Corrosion Resistant Non-metallic	D I M
	200V	230V	460V	575V		Catalog No.		☉ Catalog No.		☉ Catalog No.		☉ Catalog No.	
						CATN		CATN		CATN		CATN	
00	1.5	1.5	2	2	15	7-12-*◆-TBH15G0	C2	7-12-*◆-TBH15D0	C3	7-12-*◆-TBH15W0	C2	7-12-*◆-TBH15C0	V2
0	2	3	5	5	15	7-16-*◆-TBH15G0	C2	7-16-*◆-TBH15D0	C3	7-16-*◆-TBH15W0	C2	7-16-*◆-TBH15C0	V2
1	~	~	7.5	10	20	7-37-*◆-TBH20G0	C2	7-37-*◆-TBH20D0	C3	7-37-*◆-TBH20W0	C2	7-37-*◆-TBH20C0	V2
2	~	~	~	15	35	7-43-*◆-TBH35G0	C2	7-43-*◆-TBH35D0	C3	7-43-*◆-TBH35W0	C2	7-43-*◆-TBH35C0	V2
	~	~	15	20	40	7-43-*◆-TBH40G0	C2	7-43-*◆-TBH40D0	C3	7-43-*◆-TBH40W0	C2	7-43-*◆-TBH40C0	V2
	~	~	20	25	50	7-43-*◆-TBH50G0	C2	7-43-*◆-TBH50D0	C3	7-43-*◆-TBH50W0	C2	7-43-*◆-TBH50C0	V2
3	~	~	~	30	60	7-85-*◆-TBH60G0	D3	7-85-*◆-TBH60D0	Q	7-85-*◆-TBH60W0	Q	7-85-*◆-TBH60C0	W2
	~	~	30	40	80	7-85-*◆-TBH80G0	D3	7-85-*◆-TBH80D0	Q	7-85-*◆-TBH80W0	Q	7-85-*◆-TBH80C0	W2
	15	20	40	50	100	7-85-*◆-TBH100G0	D3	7-85-*◆-TBH100D0	Q	7-85-*◆-TBH100W0	Q	7-85-*◆-TBH100C0	W2

NOTE: Catalog numbers and enclosure dimensions reflect contactors with AC coils. For DC coils, select Coil Code from the DC Coil Code table on page C104 and follow the instructions for modifying catalog numbers.

Ordering Instructions

Specify Catalog Number	
Replace (*) with Coil Code	See page C104
Replace (◆) with O/L Relay	See pages C105-C106
Factory Modifications available	See pages C107-C111

- ☉ Dimensional information starts on page C122.
- ☉ For Type 3R outdoor applications, replace "D" in catalog number with an "R". Dimensions may change. For example number CATN7-37-*◆-TBH40D0 becomes CATN7-37-*◆-TBH40R0.

Series CATN7 208V AC with Thermal-Magnetic Circuit Breaker ②

NEMA Size	Max HP 3-Phase ①	Adjustment Range	MCCB Amps	Type 1 Metallic General Purpose	D I M	Type 3R Metallic Outdoor Raintight	D I M	
				Catalog No.		③ Catalog No.		
00	208V	0.25	0.2...1.0	15	CATN7-12-XA-1EBB-TB15G17-L11	C2	CATN7-12-XA-1EBB-TB15R17-L11	0
		0.5	1.0...5.0	15	CATN7-12-XA-1ECB-TB15G17-L11	C2	CATN7-12-XA-1ECB-TB15R17-L11	0
		0.75	1.0...5.0	15	CATN7-12-XA-1ECB-TB15G17-L11	C2	CATN7-12-XA-1ECB-TB15R17-L11	0
		1	1.0...5.0	15	CATN7-12-XA-1ECB-TB15G17-L11	C2	CATN7-12-XA-1ECB-TB15R17-L11	0
		1.5	3.2...16	15	CATN7-12-XA-1EDB-TB15G17-L11	C2	CATN7-12-XA-1EDB-TB15R17-L11	0
0	208V	2	3.2...16	15	CATN7-16-XA-1EDB-TB15G17-L11	C2	CATN7-16-XA-1EDB-TB15R17-L11	0
		3	3.2...16	20	CATN7-16-XA-1EDB-TB20G17-L11	C2	CATN7-16-XA-1EDB-TB20R17-L11	0
1	208V	5	5.4...27	35	CATN7-37-XA-1EED-TB35G17-L11	C2	CATN7-37-XA-1EED-TB35R17-L11	0
		7.5	5.4...27	50	CATN7-37-XA-1EED-TB50G17-L11	C2	CATN7-37-XA-1EED-TB50R17-L11	0
2	208V	10	11...55	60	CATN7-43-XA-1EFD-TB60G17-L11	C2	CATN7-43-XA-1EFD-TB60R17-L11	0
3	208V	15	20...100	100	CATN7-85-XA-1EGE-TB100G17-L11	D3	CATN7-85-XA-1EGE-TB100R17-L11	0
		20	20...100	125	CATN7-85-XA-1EGE-TB125G17-L11	D3	CATN7-85-XA-1EGE-TB125R17-L11	0
		25	20...100	125	CATN7-85-XA-1EGE-TB125G17-L11	D3	CATN7-85-XA-1EGE-TB125R17-L11	0

Full Voltage Non-Reversing (FVNR) Features include:

- NEMA-sized CAN7 contactor
- CEP7 Electronic Overload Relay
- Control Circuit Transformer
- Hand-Off-Auto (H-O-A) selector switch
- Red Run pilot light
- 2-NO and 1-NC auxiliaries for customer use
- Class CC Fuse holder as fused primary of CCT
- Reset pushbutton
- UL489 600V class thermal-magnetic molded case circuit breaker

C
NEMA Starters

Series CATN7 230V AC with Thermal-Magnetic Circuit Breaker ②

NEMA Size	Max HP 3-Phase ①	Adjustment Range	MCCB Amps	Type 1 Metallic General Purpose	D I M	Type 3R Metallic Outdoor Raintight	D I M	
				Catalog No.		③ Catalog No.		
00	230V	0.25	0.2...1.0	15	CATN7-12-XB-1EBB-TB15G17-L11	C2	CATN7-12-XB-1EBB-TB15R17-L11	0
		0.5	1.0...5.0	15	CATN7-12-XB-1ECB-TB15G17-L11	C2	CATN7-12-XB-1ECB-TB15R17-L11	0
		0.75	1.0...5.0	15	CATN7-12-XB-1ECB-TB15G17-L11	C2	CATN7-12-XB-1ECB-TB15R17-L11	0
		1	1.0...5.0	15	CATN7-12-XB-1ECB-TB15G17-L11	C2	CATN7-12-XB-1ECB-TB15R17-L11	0
		1.5	1.0...5.0	15	CATN7-12-XB-1ECB-TB15G17-L11	C2	CATN7-12-XB-1ECB-TB15R17-L11	0
0	230V	2	3.2...16	15	CATN7-16-XB-1EDB-TB15G17-L11	C2	CATN7-16-XB-1EDB-TB15R17-L11	0
		3	3.2...16	15	CATN7-16-XB-1EDB-TB15G17-L11	C2	CATN7-16-XB-1EDB-TB15R17-L11	0
1	230V	5	5.4...27	30	CATN7-37-XB-1EED-TB30G17-L11	C2	CATN7-37-XB-1EED-TB30R17-L11	0
		7.5	5.4...27	40	CATN7-37-XB-1EED-TB40G17-L11	C2	CATN7-37-XB-1EED-TB40R17-L11	0
2	230V	10	11...55	60	CATN7-43-XB-1EFD-TB60G17-L11	C2	CATN7-43-XB-1EFD-TB60R17-L11	0
		15	11...55	80	CATN7-43-XB-1EFD-TB80G17-L11	C2	CATN7-43-XB-1EFD-TB80R17-L11	0
3	230V	20	20...100	100	CATN7-85-XB-1EGE-TB100G17-L11	D3	CATN7-85-XB-1EGE-TB100R17-L11	0
		25	20...100	125	CATN7-85-XB-1EGE-TB125G17-L11	D3	CATN7-85-XB-1EGE-TB125R17-L11	0
		30	20...100	150	CATN7-85-XB-1EGE-TB150G17-L11	D3	CATN7-85-XB-1EGE-TB150R17-L11	0

- ① HP and NEMA size selection for line voltages shown. Contact your Sprecher + Schuh representative for other voltage application.
- ② Contactors are equipped with 2 NO and 1 NC auxiliary contacts. See page C108 to order additional or different auxiliary contacts.
- ③ Dimensional information starts on page C122.

Series CATN7 460V AC with Thermal-Magnetic Circuit Breaker ②

NEMA Size	Max HP 3-Phase ①	Adjustment Range	MCCB Amps	Type 1 Metallic General Purpose	D I M	Type 3R Metallic Outdoor Raintight	D I M
				Catalog No.		③ Catalog No.	
00	460V						
	0.25	0.2...1.0	15	CATN7-12-XC-1EBB-TB15G17-L11	C2	CATN7-12-XC-1EBB-TB15R17-L11	0
	0.5	1.0...5.0	15	CATN7-12-XC-1ECB-TB15G17-L11	C2	CATN7-12-XC-1ECB-TB15R17-L11	0
	0.75	1.0...5.0	15	CATN7-12-XC-1ECB-TB15G17-L11	C2	CATN7-12-XC-1ECB-TB15R17-L11	0
	1	1.0...5.0	15	CATN7-12-XC-1ECB-TB15G17-L11	C2	CATN7-12-XC-1ECB-TB15R17-L11	0
	1.5	1.0...5.0	15	CATN7-12-XC-1ECB-TB15G17-L11	C2	CATN7-12-XC-1ECB-TB15R17-L11	0
0	2	1.0...5.0	15	CATN7-12-XC-1ECB-TB15G17-L11	C2	CATN7-12-XC-1ECB-TB15R17-L11	0
	3	3.2...16	15	CATN7-16-XC-1EDB-TB15G17-L11	C2	CATN7-16-XC-1EDB-TB15R17-L11	0
1	5	3.2...16	15	CATN7-16-XC-1EDB-TB15G17-L11	C2	CATN7-16-XC-1EDB-TB15R17-L11	0
	7.5	5.4...27	20	CATN7-37-XC-1EED-TB20G17-L11	C2	CATN7-37-XC-1EED-TB20R17-L11	0
2	10	5.4...27	30	CATN7-37-XC-1EED-TB30G17-L11	C2	CATN7-37-XC-1EED-TB30R17-L11	0
	15	11...55	40	CATN7-43-XC-1EFD-TB40G17-L11	C2	CATN7-43-XC-1EFD-TB40R17-L11	0
	20	11...55	50	CATN7-43-XC-1EFD-TB50G17-L11	C2	CATN7-43-XC-1EFD-TB50R17-L11	0
3	25	11...55	60	CATN7-43-XC-1EFD-TB60G17-L11	C2	CATN7-43-XC-1EFD-TB60R17-L11	0
	30	20...100	80	CATN7-85-XC-1EGE-TB80G17-L11	D3	CATN7-85-XC-1EGE-TB80R17-L11	0
	40	20...100	100	CATN7-85-XC-1EGE-TB100G17-L11	D3	CATN7-85-XC-1EGE-TB100R17-L11	0
	50	20...100	125	CATN7-85-XC-1EGE-TB125G17-L11	D3	CATN7-85-XC-1EGE-TB125R17-L11	0

Full Voltage Non-Reversing (FVNR) Features include:

- NEMA-sized CAN7 contactor
- CEP7 Electronic Overload Relay
- Control Circuit Transformer
- Hand-Off-Auto (H-O-A) selector switch
- Red Run pilot light
- 2-NO and 1-NC auxiliaries for customer use
- Class CC Fuse holder as fused primary of CCT
- Reset pushbutton
- UL489 600V class thermal-magnetic molded case circuit breaker

C
NEMA Starters

- ① HP and NEMA size selection for line voltages shown. Contact your Sprecher + Schuh representative for other voltage application.
- ② Contactors are equipped with 2 NO and 1 NC auxiliary contacts standard. See page C108 to order additional or different auxiliary contacts.
- ③ Dimensional information starts on page C122.

Series CATN7 575V AC with Thermal-Magnetic Circuit Breaker ②

NEMA Size	Max HP 3-Phase ①	Adjustment Range	MCCB Amps	Type 1 Metallic General Purpose (except TBH)	D I M	Type 3R Metallic Outdoor Raintight	D I M
	575V			Catalog No.		③ Catalog No.	
00	0.25	0.2...1.0	15	CATN7-12-XD-1EBB-TBH15G17-L11	C2	CATN7-12-XD-1EBB-TBH15R17-L11	0
	0.5	1.0...5.0	15	CATN7-12-XD-1ECB-TBH15G17-L11	C2	CATN7-12-XD-1ECB-TBH15R17-L11	0
	0.75	1.0...5.0	15	CATN7-12-XD-1ECB-TBH15G17-L11	C2	CATN7-12-XD-1ECB-TBH15R17-L11	0
	1	1.0...5.0	15	CATN7-12-XD-1ECB-TBH15G17-L11	C2	CATN7-12-XD-1ECB-TBH15R17-L11	0
	2	1.0...5.0	15	CATN7-12-XD-1ECB-TBH15G17-L11	C2	CATN7-12-XD-1ECB-TBH15R17-L11	0
0	3	3.2...16	15	CATN7-16-XD-1EDB-TBH15G17-L11	C2	CATN7-16-XD-1EDB-TBH15R17-L11	0
	5	3.2...16	15	CATN7-16-XD-1EDB-TBH15G17-L11	C2	CATN7-16-XD-1EDB-TBH15R17-L11	0
1	7.5 ④	5.4...27	20	CATN7-37-XD-1EED-TB20G17-L11	C2	CATN7-37-XD-1EED-TB20R17-L11	0
	10 ④	9...45	20	CATN7-37-XD-1EFD-TB20G17-L11	C2	CATN7-37-XD-1EED-TB20R17-L11	0
	7.5	5.4...27	20	CATN7-37-XD-1EED-TBH20G17-L11	C2	CATN7-37-XD-1EED-TBH20R17-L11	0
	10	11...55	20	CATN7-37-XD-1EFD-TBH20G17-L11	C2	CATN7-37-XD-1EFD-TBH20R17-L11	0
2	15 ④	11...55	35	CATN7-43-XD-1EFD-TB35G17-L11	C2	CATN7-43-XD-1EFD-TB35R17-L11	0
	20 ④	11...55	40	CATN7-43-XD-1EFD-TB40G17-L11	C2	CATN7-43-XD-1EFD-TB40R17-L11	0
	25 ④	11...55	50	CATN7-43-XD-1EFD-TB50G17-L11	C2	CATN7-43-XD-1EFD-TB50R17-L11	0
	15	11...55	35	CATN7-43-XD-1EFD-TBH35G17-L11	C2	CATN7-43-XD-1EFD-TBH35R17-L11	0
	20	11...55	40	CATN7-43-XD-1EFD-TBH40G17-L11	C2	CATN7-43-XD-1EFD-TBH40R17-L11	0
	25	11...55	50	CATN7-43-XD-1EFD-TBH50G17-L11	C2	CATN7-43-XD-1EFD-TBH50R17-L11	0
3	30 ④	20...100	60	CATN7-85-XD-1EGE-TB60G17-L11	D3	CATN7-85-XD-1EGE-TB60R17-L11	0
	40 ④	20...100	80	CATN7-85-XD-1EGE-TB80G17-L11	D3	CATN7-85-XD-1EGE-TB80R17-L11	0
	50 ④	20...100	100	CATN7-85-XD-1EGE-TB100G17-L11	D3	CATN7-85-XD-1EGE-TB100R17-L11	0
	30	20...100	60	CATN7-85-XD-1EGE-TBH60G17-L11	D3	CATN7-85-XD-1EGE-TBH60R17-L11	0
	40	20...100	80	CATN7-85-XD-1EGE-TBH80G17-L11	D3	CATN7-85-XD-1EGE-TBH80R17-L11	0
	50	20...100	100	CATN7-85-XD-1EGE-TBH100G17-L11	D3	CATN7-85-XD-1EGE-TBH100R17-L11	0

Full Voltage Non-Reversing (FVNR) Features include:

- NEMA-sized CAN7 contactor
- CEP7 Electronic Overload Relay
- Control Circuit Transformer
- Hand-Off-Auto (H-O-A) selector switch
- Red Run pilot light
- 2-NO and 1-NC auxiliaries for customer use
- Class CC Fuse holder as fused primary of CCT
- Reset pushbutton
- UL489 600V class thermal-magnetic molded case circuit breaker



NEMA Starters

- ① HP and NEMA size selection for line voltages shown. Contact your Sprecher + Schuh representative for other voltage application.
- ② Contactors are equipped with 2 NO and 1 NC auxiliary contacts standard. See page C108 to order additional or different auxiliary contacts.
- ③ Dimensional information starts on page C122.
- ④ Applicable to 600Y/347V only.

Series CATN7 with Fusible Disconnect (J-Type) ③④

NEMA Size	Maximum Horsepower Three Phase				Fuse Clip Amps	Type 1 General Purpose	D I M	Type 12 [Type 3R ②] Industrial Dusttight	D I M	Type 4 Watertight	D I M	Type 4X Watertight Corrosion Resistant Non-metallic	D I M
	200V	230V	460V	575V		Catalog No.		① Catalog No.		① Catalog No.		① Catalog No.	
						CATN		CATN		CATN		CATN	
00	1.5	1.5	2	2	30	7-12-*◆-JF61G0	C	7-12-*◆-JF61D0	C2	7-12-*◆-JF61W0	Q	7-12-*◆-JF61C0	V1
0	3	3	5	5	30	7-16-*◆-JF61G0	C	7-16-*◆-JF61D0	C2	7-16-*◆-JF61W0	Q	7-16-*◆-JF61C0	V1
1	5	5	10	10	30	7-37-*◆-JF61G0	C	7-37-*◆-JF61D0	C2	7-37-*◆-JF61W0	Q	7-37-*◆-JF61C0	V1
	7-1/2	7.5	~	~	60	7-37-*◆-JF62G0	C	7-37-*◆-JF62D0	C2	7-37-*◆-JF62W0	Q	7-37-*◆-JF62C0	V1
2	~	~	~	15	30	7-43-*◆-JF61G0	C	7-43-*◆-JF61D0	C2	7-43-*◆-JF61W0	Q	7-43-*◆-JF61C0	V1
	10	10	25	25	60	7-43-*◆-JF62G0	C	7-43-*◆-JF62D0	C2	7-43-*◆-JF62W0	Q	7-43-*◆-JF62C0	V1
	~	15	~	~	100	7-43-*◆-JF63G0	D3	7-43-*◆-JF63D0	Q	7-43-*◆-JF63W0	Q	7-43-*◆-JF63C0	W1
3	~	~	30	40	60	7-85-*◆-JF62G0	D3	7-85-*◆-JF62D0	Q	7-85-*◆-JF62W0	Q	7-85-*◆-JF62C0	W2
	20	25	50	50	100	7-85-*◆-JF63G0	D3	7-85-*◆-JF63D0	Q	7-85-*◆-JF63W0	Q	7-85-*◆-JF63C0	W2
	25	30	~	~	200	7-85-*◆-JF64G0	G	7-85-*◆-JF64D0	T	7-85-*◆-JF64W0	T	7-85-*◆-JF64C0	X1

NOTE: Catalog numbers and enclosure dimensions reflect contactors with AC coils. For DC coils, select Coil Code from the DC Coil Code table on page C104 and follow the instructions for modifying catalog numbers.

Ordering Instructions

Specify Catalog Number	
Replace (*) with Coil Code	See page C104
Replace (◆) with O/L Relay	See pages C105-C106
Factory Modifications available	See pages C107-C111

- ① Dimensional information starts on page C122.
- ② For Type 3R outdoor applications, replace "D" in catalog number with an "R". Dimensions may change. For example number CATN7-16-*◆-JF61D0 becomes CATN7-16-*◆-JF61R0.
- ③ Fusible combo starter uses the L11 Disconnect. Fuse clips accept "J" type fuses. Power fuses not supplied.
- ④ A Red and Yellow Handle may be selected instead of the standard Black handle. Change "JF" to "LF" in catalog number.

Series CATN7 208V AC with Fusible Disconnect (J-Type) ②③④

NEMA Size	Max HP 3-Phase ①	Adjustment Range	Fuse Clip Amps	Type 1 Metallic General Purpose	D I M	Type 3R Metallic Outdoor Raintight	D I M
	208V			Catalog No.		⑤ Catalog No.	
00	0.25	0.2...1.0	30	CATN7-12-XA-1EBB-JF61G17-L11	C	CATN7-12-XA-1EBB-JF61R17-L11	0
	0.5	1.0...5.0	30	CATN7-12-XA-1ECB-JF61G17-L11	C	CATN7-12-XA-1ECB-JF61R17-L11	0
	0.75	1.0...5.0	30	CATN7-12-XA-1ECB-JF61G17-L11	C	CATN7-12-XA-1ECB-JF61R17-L11	0
	1	1.0...5.0	30	CATN7-12-XA-1ECB-JF61G17-L11	C	CATN7-12-XA-1ECB-JF61R17-L11	0
	1.5	3.2...16	30	CATN7-12-XA-1EDB-JF61G17-L11	C	CATN7-12-XA-1EDB-JF61R17-L11	0
0	2	3.2...16	30	CATN7-16-XA-1EDB-JF61G17-L11	C	CATN7-16-XA-1EDB-JF61R17-L11	0
	3	3.2...16	30	CATN7-16-XA-1EDB-JF61G17-L11	C	CATN7-16-XA-1EDB-JF61R17-L11	0
1	5	5.4...27	30	CATN7-37-XA-1EED-JF61G17-L11	C	CATN7-37-XA-1EED-JF61R17-L11	0
	7.5	5.4...27	60	CATN7-37-XA-1EED-JF62G17-L11	C	CATN7-37-XA-1EED-JF62R17-L11	0
2	10	11...55	60	CATN7-43-XA-1EFD-JF62G17-L11	C	CATN7-43-XA-1EFD-JF62R17-L11	0
3	15	20...100	100	CATN7-85-XA-1EGE-JF63G17-L11	D3	CATN7-85-XA-1EGE-JF63R17-L11	0
	20	20...100	100	CATN7-85-XA-1EGE-JF63G17-L11	D3	CATN7-85-XA-1EGE-JF63R17-L11	0
	25	20...100	200	CATN7-85-XA-1EGE-JF64G17-L11	G	CATN7-85-XA-1EGE-JF64R17-L11	T

Full Voltage Non-Reversing (FVNR) Features include:

- NEMA-sized CAN7 contactor
- CEP7 Electronic Overload Relay
- Control Circuit Transformer
- Hand-Off-Auto (H-O-A) selector switch
- Red Run pilot light
- 2-NO and 1-NC auxiliaries for customer use
- Class CC Fuse holder as fused primary of CCT
- UL98 fusible L11 disconnect
- Reset pushbutton

NEMA Starters

Series CATN7 230V AC with Fusible Disconnect (J-Type) ②③④

NEMA Size	Max HP 3-Phase ①	Adjustment Range	Fuse Clip Amps	Type 1 Metallic General Purpose	D I M	Type 3R Metallic Outdoor Raintight	D I M
	230V			Catalog No.		⑤ Catalog No.	
00	0.25	0.2...1.0	30	CATN7-12-XB-1EBB-JF61G17-L11	C	CATN7-12-XB-1EBB-JF61R17-L11	0
	0.5	1.0...5.0	30	CATN7-12-XB-1ECB-JF61G17-L11	C	CATN7-12-XB-1ECB-JF61R17-L11	0
	0.75	1.0...5.0	30	CATN7-12-XB-1ECB-JF61G17-L11	C	CATN7-12-XB-1ECB-JF61R17-L11	0
	1	1.0...5.0	30	CATN7-12-XB-1ECB-JF61G17-L11	C	CATN7-12-XB-1ECB-JF61R17-L11	0
	1.5	1.0...5.0	30	CATN7-12-XB-1ECB-JF61G17-L11	C	CATN7-12-XB-1ECB-JF61R17-L11	0
0	2	3.2...16	30	CATN7-16-XB-1EDB-JF61G17-L11	C	CATN7-16-XB-1EDB-JF61R17-L11	0
	3	3.2...16	30	CATN7-16-XB-1EDB-JF61G17-L11	C	CATN7-16-XB-1EDB-JF61R17-L11	0
1	5	5.4...27	30	CATN7-37-XB-1EED-JF61G17-L11	C	CATN7-37-XB-1EED-JF61R17-L11	0
	7.5	5.4...27	60	CATN7-37-XB-1EED-JF62G17-L11	C	CATN7-37-XB-1EED-JF62R17-L11	0
2	10	11...55	60	CATN7-43-XB-1EFD-JF62G17-L11	C	CATN7-43-XB-1EFD-JF62R17-L11	0
	15	11...55	100	CATN7-43-XB-1EFD-JF63G17-L11	C	CATN7-43-XB-1EFD-JF63R17-L11	0
3	20	20...100	100	CATN7-85-XB-1EGE-JF63G17-L11	D3	CATN7-85-XB-1EGE-JF63R17-L11	0
	25	20...100	100	CATN7-85-XB-1EGE-JF63G17-L11	D3	CATN7-85-XB-1EGE-JF63R17-L11	0
	30	20...100	200	CATN7-85-XB-1EGE-JF64G17-L11	G	CATN7-85-XB-1EGE-JF64R17-L11	T

① HP and NEMA size selection for line voltages shown. Contact your Sprecher + Schuh representative for other voltage application.

② Contactors are equipped with 2 NO and 2 NC auxiliary contacts standard. See page C108 to order additional or different auxiliary contacts.

③ Fusible combo starter uses the L11 Disconnect. Fuse clips accept "J" type fuses. Power fuses not supplied.

④ A Red and Yellow Handle may be selected instead of the standard Black handle. Change "JF" to "LF" in catalog number.

⑤ Dimensional information starts on page C122.

208V Series CATN7 with Fusible Disconnect (J Type) with Power Fuses ②③④

NEMA Size	Max HP 3-Phase ①	Adjustment Range	Fuse Clip AMPS	Fuse Size	Type 1 (M1) Metallic General Purpose	D I M	Type 3R (M3) Metallic Outdoor Raintight	D I M
					Catalog Number		⑤ Catalog Number	
00	0.25	0.2...1.0	30	2	CATN7-12-XA-D1BB-JF2G17-L11	C	CATN7-12-XA-D1BB-JF2R17-L11	0
	0.5	1.0...5.0	30	3.5	CATN7-12-XA-D1CB-JF3.5G17-L11	C	CATN7-12-XA-D1CB-JF3.5R17-L11	0
	0.75	1.0...5.0	30	5	CATN7-12-XA-D1CB-JF5G17-L11	C	CATN7-12-XA-D1CB-JF5R17-L11	0
	1	1.0...5.0	30	7	CATN7-12-XA-D1CB-JF7G17-L11	C	CATN7-12-XA-D1CB-JF7R17-L11	0
	1.5	3.2...16	30	10	CATN7-12-XA-D1DB-JF10G17-L11	C	CATN7-12-XA-D1DB-JF10R17-L11	0
0	2	3.2...16	30	12	CATN7-16-XA-D1DB-JF12G17-L11	C	CATN7-16-XA-D1DB-JF12R17-L11	0
	3	3.2...16	30	15	CATN7-16-XA-D1DB-JF15G17-L11	C	CATN7-16-XA-D1DB-JF15R17-L11	0
1	5	5.4...27	30	25	CATN7-37-XA-D1ED-JF25G17-L11	C	CATN7-37-XA-D1ED-JF25R17-L11	0
	7.5	5.4...27	60	35	CATN7-37-XA-D1ED-JF35G17-L11	C	CATN7-37-XA-D1ED-JF35R17-L11	0
2	10	11...55	60	50	CATN7-43-XA-D1FD-JF50G17-L11	C	CATN7-43-XA-D1FD-JF50R17-L11	0
	15	20...100	100	70	CATN7-85-XA-D1GE-JF70G17-L11	D3	CATN7-85-XA-D1GE-JF70R17-L11	0
3	20	20...100	100	90	CATN7-85-XA-D1GE-JF90G17-L11	D3	CATN7-85-XA-D1GE-JF90R17-L11	0
	25	20...100	100	110	CATN7-85-XA-D1GE-JF110G17-L11	G	CATN7-85-XA-D1GE-JF110R17-L11	T

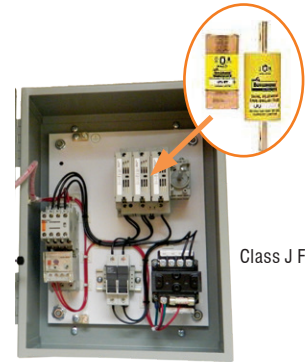

Class J Fuses

Some customers have expressed a desire to buy fusible combination motor starters with Type J power fuses installed in the motor starter. Dealers want and need power fuses installed at Sprecher + Schuh; so, they won't have to open packaging in order to install power fuses provided by others.

230V Series CATN7 with Fusible Disconnect (J Type) with Power Fuses ②③④

NEMA Size	Max HP 3-Phase ①	Adjustment Range	Fuse Clip AMPS	Fuse Size	Type 1 (M1) Metallic General Purpose	D I M	Type 3R (M3) Metallic Outdoor Raintight	D I M
					Catalog Number		⑤ Catalog Number	
00	0.25	0.2...1.0	30	1.8	CATN7-12-XB-1EBB-JF1.8G17-L11	C	CATN7-12-XB-1EBB-JF1.8G17-L11	0
	0.5	1.0...5.0	30	3.5	CATN7-12-XB-1ECB-JF3.5G17-L11	C	CATN7-12-XB-1ECB-JF3.5G17-L11	0
	0.75	1.0...5.0	30	5	CATN7-12-XB-1ECB-JF5G17-L11	C	CATN7-12-XB-1ECB-JF5G17-L11	0
	1	1.0...5.0	30	6.25	CATN7-12-XB-1ECB-JF6.25G17-L11	C	CATN7-12-XB-1ECB-JF6.25G17-L11	0
	1.5	3.2...16	30	9	CATN7-12-XB-1EDB-JF9G17-L11	C	CATN7-12-XB-1EDB-JF9G17-L11	0
0	2	3.2...16	30	10	CATN7-16-XB-1EDB-JF10G17-L11	C	CATN7-16-XB-1EDB-JF10G17-L11	0
	3	3.2...16	30	15	CATN7-16-XB-1EDB-JF15G17-L11	C	CATN7-16-XB-1EDB-JF15G17-L11	0
1	5	5.4...27	30	25	CATN7-37-XB-1EED-JF25G17-L11	C	CATN7-37-XB-1EED-JF25G17-L11	0
	7.5	5.4...27	60	35	CATN7-37-XB-1EED-JF35G17-L11	C	CATN7-37-XB-1EED-JF35G17-L11	0
2	10	11...55	60	40	CATN7-43-XB-1EFD-JF40G17-L11	C	CATN7-43-XB-1EFD-JF40G17-L11	0
	15	11...55	60	70	CATN7-43-XB-1EFD-JF70G17-L11	C	CATN7-43-XB-1EFD-JF70G17-L11	0
3	20	20...100	100	80	CATN7-85-XB-1EGE-JF80G17-L11	D3	CATN7-85-XB-1EGE-JF80G17-L11	0
	25	20...100	100	100	CATN7-85-XB-1EGE-JF100G17-L11	D3	CATN7-85-XB-1EGE-JF100G17-L11	0
	30	20...100	200	125	CATN7-85-XB-1EGE-JF125G17-L11	G	CATN7-85-XB-1EGE-JF125G17-L11	T

Full Voltage Non-Reversing (FVNR) Features include:

- NEMA-sized CAN7 contactor
- CEP7 Electronic Overload Relay
- Control Circuit Transformer
- Hand-Off-Auto (H-O-A) selector switch
- Red Run pilot light
- 2-NO and 1-NC auxiliaries for customer use
- Class CC Fuse holder as fused primary of CCT
- UL98 fusible L11 disconnect and included with set of line power fuses
- Reset pushbutton

① HP and NEMA size selection for line voltages shown. Contact your Sprecher + Schuh representative for other voltage application.

② Contactors are equipped with 2 NO and 1 NC auxiliary contact standard. See Modification Section to order additional or different auxiliary contacts.

③ Fusible combo starter uses the L11 Disconnect. Fuse clips accept "J" type fuses. Power fuses are supplied with this specific assembly.

④ A Red and Yellow Handle may be selected instead of the standard Black handle. Change "JF" to "LF" in catalog number.

⑤ Dimensional information starts on page C122.

Series CATN7 460V AC with Fusible Disconnect (J-Type) ③④

NEMA Size	Max HP 3-Phase ①	Adjustment Range	Fuse Clip AMPS	Type 1 Metallic General Purpose	D I M	Type 3R Metallic Outdoor Raintight	D I M
				Catalog No.		⑤ Catalog No.	
00	0.25	0.2...1.0	30	CATN7-12-XC-1EBB-JF61G17-L11	C	CATN7-12-XC-1EBB-JF61R17-L11	0
	0.5	1.0...5.0	30	CATN7-12-XC-1ECB-JF61G17-L11	C	CATN7-12-XC-1ECB-JF61R17-L11	0
	0.75	1.0...5.0	30	CATN7-12-XC-1ECB-JF61G17-L11	C	CATN7-12-XC-1ECB-JF61R17-L11	0
	1	1.0...5.0	30	CATN7-12-XC-1ECB-JF61G17-L11	C	CATN7-12-XC-1ECB-JF61R17-L11	0
	1.5	1.0...5.0	30	CATN7-12-XC-1ECB-JF61G17-L11	C	CATN7-12-XC-1ECB-JF61R17-L11	0
	2	1.0...5.0	30	CATN7-12-XC-1ECB-JF61G17-L11	C	CATN7-12-XC-1ECB-JF61R17-L11	0
0	3	3.2...16	30	CATN7-16-XC-1EDB-JF61G17-L11	C	CATN7-16-XC-1EDB-JF61R17-L11	0
	5	3.2...16	30	CATN7-16-XC-1EDB-JF61G17-L11	C	CATN7-16-XC-1EDB-JF61R17-L11	0
1	7.5	5.4...27	30	CATN7-37-XC-1EED-JF61G17-L11	C	CATN7-37-XC-1EED-JF61R17-L11	0
	10	5.4...27	30	CATN7-37-XC-1EED-JF61G17-L11	C	CATN7-37-XC-1EED-JF61R17-L11	0
2	15	11...55	60	CATN7-43-XC-1EFD-JF62G17-L11	C	CATN7-43-XC-1EFD-JF62R17-L11	0
	20	11...55	60	CATN7-43-XC-1EFD-JF62G17-L11	C	CATN7-43-XC-1EFD-JF62R17-L11	0
	25	11...55	60	CATN7-43-XC-1EFD-JF62G17-L11	C	CATN7-43-XC-1EFD-JF62R17-L11	0
3	30	20...100	60	CATN7-85-XC-1EGE-JF62G17-L11	D3	CATN7-85-XC-1EGE-JF62R17-L11	0
	40	20...100	100	CATN7-85-XC-1EGE-JF63G17-L11	D3	CATN7-85-XC-1EGE-JF63R17-L11	0
	50	20...100	100	CATN7-85-XC-1EGE-JF63G17-L11	D3	CATN7-85-XC-1EGE-JF63R17-L11	0

Full Voltage Non-Reversing (FVNR) Features include:

- NEMA-sized CAN7 contactor
- CEP7 Electronic Overload Relay
- Control Circuit Transformer
- Hand-Off-Auto (H-O-A) selector switch
- Red Run pilot light
- 2-NO and 1-NC auxiliaries for customer use
- Class CC Fuse holder as fused primary of CCT
- UL98 fusible L11 disconnect
- Reset pushbutton

Series CATN7 575V AC with Fusible Disconnect (J-Type) ③④

NEMA Size	Max HP 3-Phase ①	Adjustment Range	Fuse Clip AMPS	Type 1 Metallic General Purpose	D I M	Type 3R Metallic Outdoor Raintight	D I M
				Catalog No.		⑤ Catalog No.	
00	0.25	0.2...1.0	30	CATN7-12-XD-1EBB-JF61G17-L11	C	CATN7-12-XD-1EBB-JF61R17-L11	0
	0.5	1.0...5.0	30	CATN7-12-XD-1ECB-JF61G17-L11	C	CATN7-12-XD-1ECB-JF61R17-L11	0
	0.75	1.0...5.0	30	CATN7-12-XD-1ECB-JF61G17-L11	C	CATN7-12-XD-1ECB-JF61R17-L11	0
	1	1.0...5.0	30	CATN7-12-XD-1ECB-JF61G17-L11	C	CATN7-12-XD-1ECB-JF61R17-L11	0
	2	1.0...5.0	30	CATN7-12-XD-1ECB-JF61G17-L11	C	CATN7-12-XD-1ECB-JF61R17-L11	0
	0	3	3.2...16	30	CATN7-16-XD-1EDB-JF61G17-L11	C	CATN7-16-XD-1EDB-JF61R17-L11
5		3.2...16	30	CATN7-16-XD-1EDB-JF61G17-L11	C	CATN7-16-XD-1EDB-JF61R17-L11	0
1	7.5	5.4...27	30	CATN7-37-XD-1EED-JF61G17-L11	C	CATN7-37-XD-1EED-JF61R17-L11	0
	10	5.4...27	30	CATN7-37-XD-1EED-JF61G17-L11	C	CATN7-37-XD-1EED-JF61R17-L11	0
2	15	11...55	30	CATN7-43-XD-1EFD-JF61G17-L11	C	CATN7-43-XD-1EFD-JF61R17-L11	0
	20	11...55	60	CATN7-43-XD-1EFD-JF62G17-L11	C	CATN7-43-XD-1EFD-JF62R17-L11	0
	25	11...55	60	CATN7-43-XD-1EFD-JF62G17-L11	C	CATN7-43-XD-1EFD-JF62R17-L11	0
3	30	20...100	60	CATN7-85-XD-1EGE-JF62G17-L11	D3	CATN7-85-XD-1EGE-JF62R17-L11	0
	40	20...100	60	CATN7-85-XD-1EGE-JF62G17-L11	D3	CATN7-85-XD-1EGE-JF62R17-L11	0
	50	20...100	100	CATN7-85-XD-1EGE-JF63G17-L11	D3	CATN7-85-XD-1EGE-JF63R17-L11	0

- ① HP and NEMA size selection for line voltages shown. Contact your Sprecher + Schuh representative for other voltage application.
- ② Contactors are equipped with 2 NO and 1 NC auxiliary contacts standard. See page C108 to order additional or different auxiliary contacts.
- ③ Fusible combo starter uses the L11 Disconnect. Fuse clips accept "J" type fuses. Power fuses not supplied.

- ④ A Red and Yellow Handle may be selected instead of the standard Black handle. Change "JF" to "LF" in catalog number.
- ⑤ Dimensional information starts on page C122.

460V Series CATN7 with Fusible Disconnect (J Type) ②③④

NEMA Size	Max HP 3-Phase ①	Adjustment Range	Fuse Clip Amps	Fuse Size	Type 1 (M1) Metallic General Purpose	D I M	Type 3R (M3) Metallic Outdoor Raintight	D I M
					Catalog Number		⑤ Catalog Number	
00	0.25	0.2...1.0	30	1	CATN7-12-XC-1EBB-JF1G17-L11	C	CATN7-12-XC-1EBB-JF1R17-L11	0
	0.5	1.0...5.0	30	1.6	CATN7-12-XC-1ECB-JF1.6G17-L11	C	CATN7-12-XC-1ECB-JF1.6R17-L11	0
	0.75	1.0...5.0	30	2.25	CATN7-12-XC-1ECB-JF2.25G17-L11	C	CATN7-12-XC-1ECB-JF2.25R17-L11	0
	1	1.0...5.0	30	3.2	CATN7-12-XC-1ECB-JF3.2G17-L11	C	CATN7-12-XC-1ECB-JF3.2R17-L11	0
	1.5	1.0...5.0	30	4.5	CATN7-12-XC-1ECB-JF4.5G17-L11	C	CATN7-12-XC-1ECB-JF4.5R17-L11	0
	2	3.2...16	30	5	CATN7-12-XC-1EDB-JF5G17-L11	C	CATN7-12-XC-1EDB-JF5R17-L11	0
0	3	3.2...16	30	8	CATN7-16-XC-1EDB-JF8G17-L11	C	CATN7-16-XC-1EDB-JF8R17-L11	0
	5	3.2...16	30	12	CATN7-16-XC-1EDB-JF12G17-L11	C	CATN7-16-XC-1EDB-JF12R17-L11	0
1	7.5	5.4...27	30	17.5	CATN7-37-XC-1EED-JF17.5G17-L11	C	CATN7-37-XC-1EED-JF17.5R17-L11	0
	10	5.4...27	30	20	CATN7-37-XC-1EED-JF20G17-L11	C	CATN7-37-XC-1EED-JF20R17-L11	0
2	15	11...55	60	35	CATN7-43-XC-1EFD-JF35G17-L11	C	CATN7-43-XC-1EFD-JF35R17-L11	0
	20	11...55	60	40	CATN7-43-XC-1EFD-JF40G17-L11	C	CATN7-43-XC-1EFD-JF40R17-L11	0
	25	11...55	60	50	CATN7-43-XC-1EFD-JF50G17-L11	C	CATN7-43-XC-1EFD-JF50R17-L11	0
3	30	20...100	60	60	CATN7-85-XC-1EGE-JF60G17-L11	D3	CATN7-85-XC-1EGE-JF60R17-L11	0
	40	20...100	100	80	CATN7-85-XC-1EGE-JF80G17-L11	D3	CATN7-85-XC-1EGE-JF80R17-L11	0
	50	20...100	100	100	CATN7-85-XC-1EGE-JF100G17-L11	D3	CATN7-85-XC-1EGE-JF100R17-L11	0

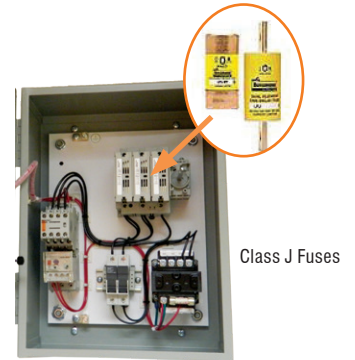

Class J Fuses

Some customers have expressed a desire to buy fusible combination motor starters with Type J power fuses installed in the motor starter. Dealers want and need power fuses installed at Sprecher + Schuh; so, they won't have to open packaging in order to install power fuses provided by others.

575V Series CATN7 with Fusible Disconnect (J Type) ②③④

NEMA Size	Max HP 3-Phase ①	Adjustment Range	Fuse Clip Amp	Fuse Size	Type 1 (M1) Metallic General Purpose	D I M	Type 3R (M3) Metallic Outdoor Raintight	D I M
					Catalog Number		⑤ Catalog Number	
00	0.25	0.2...1.0	30	1	CATN7-12-XD-1EBB-JF1G17-L11	C	CATN7-12-XD-1EBB-JF1R17-L11	0
	0.5	1.0...5.0	30	1.5	CATN7-12-XD-1ECB-JF1.5G17-L11	C	CATN7-12-XD-1ECB-JF1.5R17-L11	0
	0.75	1.0...5.0	30	2	CATN7-12-XD-1ECB-JF2G17-L11	C	CATN7-12-XD-1ECB-JF2R17-L11	0
	1	1.0...5.0	30	2.8	CATN7-12-XD-1ECB-JF2.8G17-L11	C	CATN7-12-XD-1ECB-JF2.8R17-L11	0
	1.5	1.0...5.0	30	3.5	CATN7-12-XD-1ECB-JF3.5G17-L11	C	CATN7-12-XD-1ECB-JF3.5R17-L11	0
	2	1.0...5.0	30	4	CATN7-12-XD-1ECB-JF4G17-L11	C	CATN7-12-XD-1ECB-JF4R17-L11	0
0	3	3.2...16	30	6	CATN7-16-XD-1EDB-JF6G17-L11	C	CATN7-16-XD-1EDB-JF6R17-L11	0
	5	3.2...16	30	10	CATN7-16-XD-1EDB-JF10G17-L11	C	CATN7-16-XD-1EDB-JF10R17-L11	0
1	7.5	5.4...27	30	15	CATN7-37-XD-1EED-JF15G17-L11	C	CATN7-37-XD-1EED-JF15R17-L11	0
	10	5.4...27	30	17.5	CATN7-37-XD-1EED-JF17.5G17-L11	C	CATN7-37-XD-1EED-JF17.5R17-L11	0
2	15	11...55	30	25	CATN7-43-XD-1EFD-JF25G17-L11	C	CATN7-43-XD-1EFD-JF25R17-L11	0
	20	11...55	60	35	CATN7-43-XD-1EFD-JF35G17-L11	C	CATN7-43-XD-1EFD-JF35R17-L11	0
	25	11...55	60	40	CATN7-43-XD-1EFD-JF40G17-L11	C	CATN7-43-XD-1EFD-JF40R17-L11	0
3	30	20...100	60	50	CATN7-85-XD-1EGE-JF50G17-L11	D3	CATN7-85-XD-1EGE-JF50R17-L11	0
	40	20...100	60	60	CATN7-85-XD-1EGE-JF60G17-L11	D3	CATN7-85-XD-1EGE-JF60R17-L11	0
	50	20...100	100	80	CATN7-85-XD-1EGE-JF80G17-L11	D3	CATN7-85-XD-1EGE-JF80R17-L11	0

Full Voltage Non-Reversing (FVNR) Features include:

- NEMA-sized CAN7 contactor
- CEP7 Electronic Overload Relay
- Control Circuit Transformer
- Hand-Off-Auto (H-O-A) selector switch
- Red Run pilot light
- 2-NO and 1-NC auxiliaries for customer use
- Class CC Fuse holder as fused primary of CCT
- UL98 fusible L11 disconnect and included with set of line power fuses
- Reset pushbutton

① HP and NEMA size selection for line voltages shown. Contact your Sprecher + Schuh representative for other voltage application.
 ② Contactors are equipped with 2 NO and 1 NC auxiliary contacts standard. See page C108 to order additional or different auxiliary contacts.
 ③ Fusible combo starter uses the L11 Disconnect. Fuse clips accept "J" type fuses. Power fuses are supplied with this specific assembly.
 ④ A Red and Yellow Handle may be selected instead of the standard Black handle. Change "JF" to "LF" in catalog number.
 ⑤ Dimensional information starts on page C122.

Series CATN7 with Non-Fusible Disconnect ③④

NEMA Size	Maximum Horsepower Three Phase				Disc Size/Amps	Type 1 General Purpose	D I M	Type 12 [Type 3R ②] Industrial Dusttight	D I M
	200V	230V	460V	575V		Catalog No.		① Catalog No.	
00	1.5	1.5	2	2	30	CATN7-12-*-*♦-JU61G0	C	CATN7-12-*-*♦-JU61D0	C2
0	3	3	5	5	30	CATN7-16-*-*♦-JU61G0	C	CATN7-16-*-*♦-JU61D0	C2
1	5	7.5	10	10	30	CATN7-37-*-*♦-JU61G0	C	CATN7-37-*-*♦-JU61D0	C2
	7.5	~	~	~	60	CATN7-37-*-*♦-JU62G0	C	CATN7-37-*-*♦-JU62D0	C2
2	~	~	15	15	30	CATN7-43-*-*♦-JU61G0	C	CATN7-43-*-*♦-JU61D0	C2
	10	15	25	25	60	CATN7-43-*-*♦-JU62G0	C	CATN7-43-*-*♦-JU62D0	C2
3	15	~	30	40	60	CATN7-85-*-*♦-JU62G0	D3	CATN7-85-*-*♦-JU62D0	Q
	25	30	50	50	100	CATN7-85-*-*♦-JU63G0	D3	CATN7-85-*-*♦-JU63D0	Q

Series CATN7 with Non-Fusible Disconnect ③④

NEMA Size	Maximum Horsepower Three Phase				Disc Size/Amps	Type 4 Watertight	D I M	Type 4X Watertight Corrosion Resistant Non-metallic	D I M
	200V	230V	460V	575V		Catalog No.		① Catalog No.	
00	1.5	1.5	2	2	30	CATN7-12-*-*♦-JU61W0	Q	CATN7-12-*-*♦-JU61C0	V1
0	3	3	5	5	30	CATN7-16-*-*♦-JU61W0	Q	CATN7-16-*-*♦-JU61C0	V1
1	5	7.5	10	10	30	CATN7-37-*-*♦-JU61W0	Q	CATN7-37-*-*♦-JU61C0	V1
	7.5	~	~	~	60	CATN7-37-*-*♦-JU62W0	Q	CATN7-37-*-*♦-JU62C0	V1
2	~	~	15	15	30	CATN7-43-*-*♦-JU61W0	Q	CATN7-43-*-*♦-JU61C0	V1
	10	15	25	25	60	CATN7-43-*-*♦-JU62W0	Q	CATN7-43-*-*♦-JU62C0	V1
3	15	~	30	40	60	CATN7-85-*-*♦-JU62W0	Q	CATN7-85-*-*♦-JU62C0	W2
	25	30	50	50	100	CATN7-85-*-*♦-JU63W0	Q	CATN7-85-*-*♦-JU63C0	W2

NOTE: Catalog numbers and enclosure dimensions reflect contactors with AC coils. For DC coils, select Coil Code from the DC Coil Code table on page C104 and follow the instructions for modifying catalog numbers.

Ordering Instructions

Specify Catalog Number	
Replace (*) with Coil Code	See page C104 See pages C105-C106 See pages C107-C111
Replace (♦) with O/L Relay	
Factory Modifications available	

- ① Dimensional information starts on page C122.
- ② For Type 3R outdoor applications, replace "D" in catalog number with an "R". Dimensions may change. For example number CATN7-16-*-*♦-JU61D0 becomes CATN7-16-*-*♦-JU61R0.
- ③ Non-fusible combo-starter uses the L11 Non-Fusible Disconnect.
- ④ A Red and Yellow Handle may be selected instead of the standard Black handle. Change "JU" to "LU" in catalog number.

Series CATN7 @208V AC with Non-Fusible Disconnect ②③④

NEMA Size	Max HP 3-Phase ①	Adjustment Range	Disc Size/ Amps	Type 1 Metallic General Purpose	D I M	Type 3R Metallic Outdoor Raintight	D I M
				Catalog No.		⑥ Catalog No.	
00	0.25	0.2...1.0	30	CATN7-12-XA-1EBB-JU61G17-L11	C	CATN7-12-XA-1EBB-JU61R17-L11	0
	0.5	1.0...5.0	30	CATN7-12-XA-1ECB-JU61G17-L11	C	CATN7-12-XA-1ECB-JU61R17-L11	0
	0.75	1.0...5.0	30	CATN7-12-XA-1ECB-JU61G17-L11	C	CATN7-12-XA-1ECB-JU61R17-L11	0
	1	1.0...5.0	30	CATN7-12-XA-1ECB-JU61G17-L11	C	CATN7-12-XA-1ECB-JU61R17-L11	0
	1.5	3.2...16	30	CATN7-12-XA-1EDB-JU61G17-L11	C	CATN7-12-XA-1EDB-JU61R17-L11	0
0	2	3.2...16	30	CATN7-16-XA-1EDB-JU61G17-L11	C	CATN7-16-XA-1EDB-JU61R17-L11	0
	3	3.2...16	30	CATN7-16-XA-1EDB-JU61G17-L11	C	CATN7-16-XA-1EDB-JU61R17-L11	0
1	5	5.4...27	30	CATN7-37-XA-1EED-JU61G17-L11	C	CATN7-37-XA-1EED-JU61R17-L11	0
	7.5	5.4...27	30	CATN7-37-XA-1EED-JU61G17-L11	C	CATN7-37-XA-1EED-JU61R17-L11	0
2	10	11...55	60	CATN7-43-XA-1EFD-JU62G17-L11	C	CATN7-43-XA-1EFD-JU62R17-L11	0
3	15	20...100	60	CATN7-85-XA-1EGE-JU62G17-L11	D3	CATN7-85-XA-1EGE-JU62R17-L11	0
	20	20...100	100	CATN7-85-XA-1EGE-JU63G17-L11	D3	CATN7-85-XA-1EGE-JU63R17-L11	0
	25	20...100	100	CATN7-85-XA-1EGE-JU63G17-L11	D3	CATN7-85-XA-1EGE-JU63R17-L11	0

- Full Voltage Non-Reversing (FVNR) Features include:**
- NEMA-sized CAN7 contactor
 - CEP7 Electronic Overload Relay
 - Control Circuit Transformer
 - Hand-Off-Auto (H-O-A) selector switch
 - Red Run pilot light
 - 2-NO and 1-NC auxiliaries for customer use
 - Class CC Fuse holder as fused primary of CCT
 - UL98 non-fusible L11 disconnect switch
 - Reset pushbutton

1.0...5.0

Series CATN7 @230V AC with Non-Fusible Disconnect ②③④

NEMA Size	Max HP 3-Phase ⑥	Adjustment Range	Disc Size/ Amps	Type 1 Metallic General Purpose	D I M	Type 3R Metallic Outdoor Raintight	D I M
				Catalog No.		⑥ Catalog No.	
00	0.25	0.2...1.0	30	CATN7-12-XB-1EBB-JU61G17-L11	C	CATN7-12-XB-1EBB-JU61R17-L11	0
	0.5	1.0...5.0	30	CATN7-12-XB-1ECB-JU61G17-L11	C	CATN7-12-XB-1ECB-JU61R17-L11	0
	0.75	1.0...5.0	30	CATN7-12-XB-1ECB-JU61G17-L11	C	CATN7-12-XB-1ECB-JU61R17-L11	0
	1	1.0...5.0	30	CATN7-12-XB-1ECB-JU61G17-L11	C	CATN7-12-XB-1ECB-JU61R17-L11	0
	1.5	1.0...5.0	30	CATN7-12-XB-1ECB-JU61G17-L11	C	CATN7-12-XB-1ECB-JU61R17-L11	0
0	2	3.2...16	30	CATN7-16-XB-1EDB-JU61G17-L11	C	CATN7-16-XB-1EDB-JU61R17-L11	0
	3	3.2...16	30	CATN7-16-XB-1EDB-JU61G17-L11	C	CATN7-16-XB-1EDB-JU61R17-L11	0
1	5	5.4...27	30	CATN7-37-XB-1EED-JU61G17-L11	C	CATN7-37-XB-1EED-JU61R17-L11	0
	7.5	5.4...27	30	CATN7-37-XB-1EED-JU61G17-L11	C	CATN7-37-XB-1EED-JU61R17-L11	0
2	10	11...55	60	CATN7-43-XB-1EFD-JU62G17-L11	C	CATN7-43-XB-1EFD-JU62R17-L11	0
	15	11...55	60	CATN7-43-XB-1EFD-JU62G17-L11	C	CATN7-43-XB-1EFD-JU62R17-L11	0
3	20	20...100	100	CATN7-85-XB-1EGE-JU63G17-L11	D3	CATN7-85-XB-1EGE-JU63R17-L11	0
	25	20...100	100	CATN7-85-XB-1EGE-JU63G17-L11	D3	CATN7-85-XB-1EGE-JU63R17-L11	0
	30	20...100	100	CATN7-85-XB-1EGE-JU63G17-L11	D3	CATN7-85-XB-1EGE-JU63R17-L11	0

- ① HP and NEMA size selection shown for 208V ratings only. Contact your Sprecher + Schuh representative for other voltage application.
- ② Contactors are equipped with 2 NO and 1 NC auxiliary contacts standard. See page C108 to order additional or different auxiliary contacts.
- ③ Fusible combo starter uses the L11 Disconnect. Fuse clips accept "J" type fuses. Power fuses not supplied.
- ④ A Red and Yellow Handle may be selected instead of the standard Black handle. Change "JF" to "LF" in catalog number.
- ⑤ HP and NEMA size selection shown for 230V ratings only. Contact your Sprecher + Schuh representative for other voltage application.
- ⑥ Dimensional information starts on page C122.

Series CATN7 @460V AC with Non-Fusible Disconnect ②③④

NEMA Size	Max HP 3-Phase ①	Adjustment Range	Disc Size/ Amps	Type 1 Metallic General Purpose	D I M	Type 3R Metallic Outdoor Raintight	D I M
				Catalog No.		⑥ Catalog No.	
00	0.25	0.2...1.0	30	CATN7-12-XC-1EBB-JU61G17-L11	C	CATN7-12-XC-1EBB-JU61R17-L11	0
	0.5	1.0...5.0	30	CATN7-12-XC-1ECB-JU61G17-L11	C	CATN7-12-XC-1ECB-JU61R17-L11	0
	0.75	1.0...5.0	30	CATN7-12-XC-1ECB-JU61G17-L11	C	CATN7-12-XC-1ECB-JU61R17-L11	0
	1	1.0...5.0	30	CATN7-12-XC-1ECB-JU61G17-L11	C	CATN7-12-XC-1ECB-JU61R17-L11	0
	1.5	1.0...5.0	30	CATN7-12-XC-1ECB-JU61G17-L11	C	CATN7-12-XC-1ECB-JU61R17-L11	0
	2	1.0...5.0	30	CATN7-12-XC-1ECB-JU61G17-L11	C	CATN7-12-XC-1ECB-JU61R17-L11	0
0	3	3.2...16	30	CATN7-16-XC-1EDB-JU61G17-L11	C	CATN7-16-XC-1EDB-JU61R17-L11	0
	5	3.2...16	30	CATN7-16-XC-1EDB-JU61G17-L11	C	CATN7-16-XC-1EDB-JU61R17-L11	0
1	7.5	5.4...27	30	CATN7-37-XC-1EED-JU61G17-L11	C	CATN7-37-XC-1EED-JU61R17-L11	0
	10	5.4...27	30	CATN7-37-XC-1EED-JU61G17-L11	C	CATN7-37-XC-1EED-JU61R17-L11	0
2	15	11...55	30	CATN7-43-XC-1EFD-JU61G17-L11	C	CATN7-43-XC-1EFD-JU61R17-L11	0
	20	11...55	60	CATN7-43-XC-1EFD-JU62G17-L11	C	CATN7-43-XC-1EFD-JU62R17-L11	0
	25	11...55	60	CATN7-43-XC-1EFD-JU62G17-L11	C	CATN7-43-XC-1EFD-JU62R17-L11	0
3	30	20...100	60	CATN7-85-XC-1EGE-JU62G17-L11	D3	CATN7-85-XC-1EGE-JU62R17-L11	0
	40	20...100	100	CATN7-85-XC-1EGE-JU63G17-L11	D3	CATN7-85-XC-1EGE-JU63R17-L11	0
	50	20...100	100	CATN7-85-XC-1EGE-JU63G17-L11	D3	CATN7-85-XC-1EGE-JU63R17-L11	0

Full Voltage Non-Reversing (FVNR) Features include:

- NEMA-sized CAN7 contactor
- CEP7 Electronic Overload Relay
- Control Circuit Transformer
- Hand-Off-Auto (H-O-A) selector switch
- Red Run pilot light
- 2-NO and 1-NC auxiliaries for customer use
- Class CC Fuse holder as fused primary of CCT
- UL98 non-fusible L11 disconnect switch
- Reset pushbutton

NEMA Starters

Series CATN7 @575V AC with Non-Fusible Disconnect ②③④

NEMA Size	Max HP 3-Phase ①	Adjustment Range	Disc Size/ Amps	Type 1 Metallic General Purpose	D I M	Type 3R Metallic Outdoor Raintight	D I M
				Catalog No.		⑥ Catalog No.	
00	0.25	0.2...1.0	30	CATN7-12-XD-1EBB-JU61G17-L11	C	CATN7-12-XD-1EBB-JU61R17-L11	0
	0.5	1.0...5.0	30	CATN7-12-XD-1ECB-JU61G17-L11	C	CATN7-12-XD-1ECB-JU61R17-L11	0
	0.75	1.0...5.0	30	CATN7-12-XD-1ECB-JU61G17-L11	C	CATN7-12-XD-1ECB-JU61R17-L11	0
	1	1.0...5.0	30	CATN7-12-XD-1ECB-JU61G17-L11	C	CATN7-12-XD-1ECB-JU61R17-L11	0
	2	1.0...5.0	30	CATN7-12-XD-1ECB-JU61G17-L11	C	CATN7-12-XD-1ECB-JU61R17-L11	0
	0	3	3.2...16	30	CATN7-16-XD-1EDB-JU61G17-L11	C	CATN7-16-XD-1EDB-JU61R17-L11
5		3.2...16	30	CATN7-16-XD-1EDB-JU61G17-L11	C	CATN7-16-XD-1EDB-JU61R17-L11	0
1	7.5	5.4...27	30	CATN7-37-XD-1EED-JU61G17-L11	C	CATN7-37-XD-1EED-JU61R17-L11	0
	10	5.4...27	30	CATN7-37-XD-1EED-JU61G17-L11	C	CATN7-37-XD-1EED-JU61R17-L11	0
2	15	11...55	30	CATN7-43-XD-1EFD-JU61G17-L11	C	CATN7-43-XD-1EFD-JU61R17-L11	0
	20	11...55	30	CATN7-43-XD-1EFD-JU61G17-L11	C	CATN7-43-XD-1EFD-JU61R17-L11	0
	25	11...55	60	CATN7-43-XD-1EFD-JU62G17-L11	C	CATN7-43-XD-1EFD-JU62R17-L11	0
3	30	20...100	60	CATN7-85-XD-1EGE-JU62G17-L11	D3	CATN7-85-XD-1EGE-JU62R17-L11	0
	40	20...100	60	CATN7-85-XD-1EGE-JU62G17-L11	D3	CATN7-85-XD-1EGE-JU62R17-L11	0
	50	20...100	100	CATN7-85-XD-1EGE-JU63G17-L11	D3	CATN7-85-XD-1EGE-JU63R17-L11	0

- ① HP and NEMA size selection shown for 460V ratings only. Contact your Sprecher + Schuh representative for other voltage application.
- ② Contactors are equipped with 2 NO and 1 NC auxiliary contacts standard. See page Cam almost done but it has been a struggle all day C108 to order additional or different auxiliary contacts.
- ③ Fusible combo starter uses the L11 Disconnect. Fuse clips accept "J" type fuses. Power fuses not supplied.
- ④ A Red and Yellow Handle may be selected instead of the standard Black handle. Change "JF" to "LF" in catalog number.
- ⑤ HP and NEMA size selection shown for 575V ratings only. Contact your Sprecher + Schuh representative for other voltage application.
- ⑥ Dimensional information starts on page C122.

Fireman Damper Interface for HVAC Starters

Sprecher + Schuh's fireman and damper control interface option is exclusively for HVAC markets. These options are offered in a single package modification to our standard Non-Combination or Combination starters.

Bundled Features

The Fireman and Damper interface modification is available in two control voltages; 24V or 120V AC. The selection of 24V (-FD24) or 120V AC (-FD120) for the control circuit is dependent on the damper motor control voltage and fireman override voltage which matches the control power transformer secondary (if CPT is provided). The fireman and damper modification is easily added with a simple -FD24 or -FD120 to the end of the catalog number. The control circuit voltage must be specified at the time of order entry and is not field changeable. The modifications are fully integrated and factory installed for a ready-to-use starter.

The Fireman-Damper option allows for interface with electrically operated dampers where motorized dampers must be opened before the blower motor is allowed to start. This option also accommodates a contact input from a damper limit switch to signal that the motorized damper is in fact open. An end switch for analog interface with the motorized damper would be provided by others. The run permissive option includes provision for a second remote control device which is useful if the blower is initiated from two remote control devices like a thermostat and a CO₂ sensor. The emergency shutdown feature allows for two wire connection to two terminal blocks from a remote device like an E-Stop pushbutton. This bundle of features includes a Fireman Override which will accept a two-wire powered signal from a fire control system in a remote control room. This Fireman Override feature might be used to exhaust smoke out

of a building in case of fire. Use of the Fireman Override causes the damper to open and the blower to run regardless what state the other controls one in including if Off is selected on the H-O-A switch. In case of an actual fire the Fireman Override by-passes the overload relay protection and will run the motor to destruction or the overload by-pass can be disabled for periodic testing of the override circuit. 22mm incandescent pilot lights provide clear visual indication of the mode of operation and status – no squinting to see tiny LEDs'. All the bundled options are factory wired and includes jumpers for normal operation. Until the jumper is removed and the optional remote device(s) are wired into place. This means complete flexibility to use only some or all of the features included.

Standard Features

- Shutdown Input – Customer provides a normally closed dry contact which enables the starter until the shutdown button or E-stop is depressed which opens the contact and the blower starter is disabled in the Hand or Auto mode (except in Fireman's override).
- Damper Motor – Provides a 24 or 120 VAC output as specified to actuate the damper motor when the blower starter is either in the Hand or Auto mode. This option includes a connection for a customer provided end switch, which enables the damper motor to engage via an analog signal.
- Damper Switch Input – Customer provides a normally open dry contact from the damper limit switch. This option prevents the blower starter from energizing until the damper is open.
- Remote Control Device (RCD) – Customer provides a normally open dry contact from the Remote Control Device which enables the blower starter in the Auto mode. (i.e.: thermostat or CO₂ sensor).

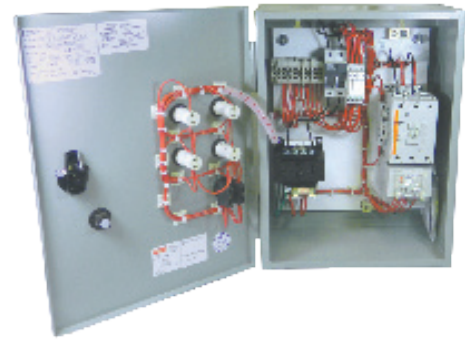

- Run Permissive – Customer provides normally closed dry contact. When the customer input contact opens the Auto mode is disabled.
- Fireman's Override – Customer provides a wet (powered) contact which energizes the damper circuit and then in turn energizes the blower motor regardless if in Hand or Auto mode, and regardless of the status of other inputs. This operation by-passes the overload relay and will run to destruction to extinguish the fire. Alternatively, a jumper can be removed for testing with the overload active in the circuit.
- Indicating lights – Four 22mm incandescent pilot lights (D7) are provided to indicate:
 - Power applied, blower motor not running (Green)
 - Auto mode selected (Blue)
 - Blower motor is running (Red)
 - Overload relay tripped (Amber)
- Factory Terminal Block Jumpers – Three factory installed terminal block jumpers are provided for shutdown, damper switch, and run permissive options which must be removed before connecting customer inputs.



Still a Compact Enclosed Starter

The fireman and damper option is available for combination and non-combination NEMA labeled HVAC starters in Type 1 or 3R enclosures. The -FD modification increases the size of the enclosure by only a few inches, thus maintaining the compact size Sprecher + Schuh starters are known for.

Minimal Size Increase

Enclosure Type	D I M	Approx. Dimension without -FD option	D I M	Approx. Dimension with -FD option
Non-Combination Starters				
Type 1	A	10 x 8 x 6	B	12 x 10 x 6
Type 1	B	12 x 10 x 6	D3	20 x 16 x 9
Type 3R	L	8 x 6 x 6	M	10 x 8 x 6
Type 3R	M	10 x 8 x 6	Q	20 x 16 x 8
Combination Starters				
Type 1	C	16 x 12 x 7	D3	20 x 16 x 9
Type 1	D3 & G	Size remains the same		
Type 3R	O & T	Size remains the same		

Catalog Numbers

Type 1 (M1) Metallic General Purpose Assembly Type	Type 3R (M3) Metallic Outdoor Raintight Assembly Type
NON-COMBO	
CATN7-12...43-X_-1E_-G17-L11	CATN7-12...43-X_-1E_-R17-L11
CATN7-85-X_-1EGE-G17-L11	CATN7-85-X_-1EGE-R17-L11
COMBO NON-FUSIBLE	
CATN7-12...43-X_-1E-JU61G17-L11	CATN7-12...43-X_-1E-JU61R17-L11
CATN7-43-X_1EFD-JU62G17-L11	CATN7-43-X_1EFD-JU62R17-L11
CATN7-85-X_-1EGE-JU62G17-L11	CATN7-85-X_-1EGE-JU62R17-L11
CATN7-85-X_-1EGE-JU63G17-L11	CATN7-85-X_-1EGE-JU63R17-L11
COMBO FUSIBLE	
CATN7-12...43-X_-1E_-JF61G17-L11	CATN7-12...43-X_-1E_-JF61R17-L11
CATN7-37...43-X_-1E_-JF62G17-L11	CATN7-37...43-X_-1E_-JF62R17-L11
CATN7-43-X_-1EFD-JF63G17-L11	CATN7-43-X_-1EFD-JF63R17-L11
CATN7-85-X_-1EGE-JF6217-L11	CATN7-85-X_-1EGE-JF6217-L11
CATN7-85-X_-1EGE-JF63G17-L11	CATN7-85-X_-1EGE-JF63R17-L11
CATN7-85-X_-1EGE-JF64G17-L11	CATN7-85-X_-1EGE-JF64R17-L11
COMBO CIRCUIT BREAKER	
CATN7-12...43-X_-1E_-TB_G17-L11	CATN7-12...43-X_-1E_-TB_R17-L11
CATN7-85-X_-1EGE-TB_G17-L11	CATN7-85-X_-1EGE-TB_R17-L11

KWIKstarters excluded from -FD* Option

- KWIKstarters as described in the HVAC Ccatalog are NOT large enough to accommodate a CPT or DIN rail mounted relays and TBs; therefore cannot be considered for inclusion of the Fireman-Damper Interface options.

C
NEMA Starters

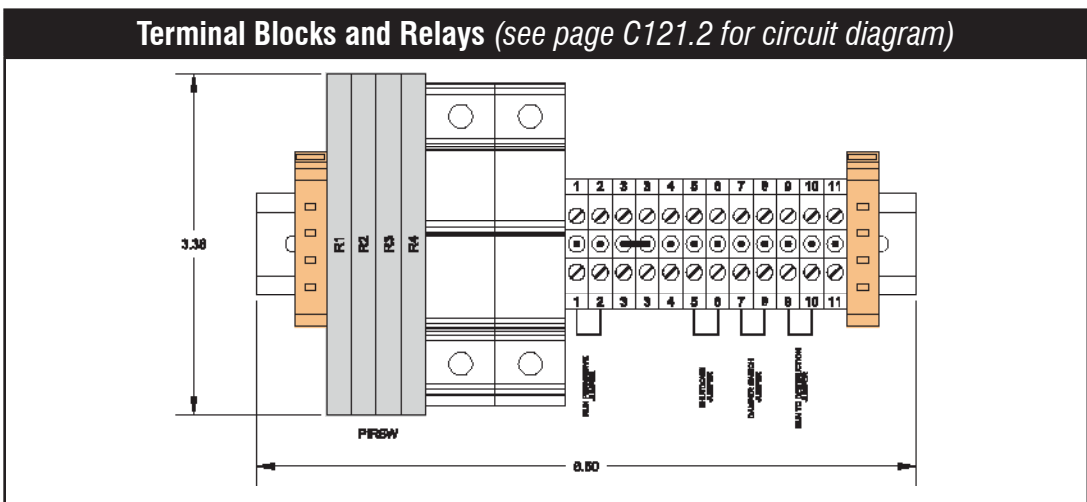

Type 1 General Purpose Enclosures ②③

Enclosure (Box) Kit Includes:

- Hinged cover
- Backpan pre-drilled for listed arrangements (not tapped)
- (2) Ground Lugs and Symbol label
- (2) 22mm knockouts for pilot devices ④
- CEP7-1ERA Overload Reset Adapter ⑤
- MR7 Reset Kit for Cover
- (2) 22mm knockouts for Reset ⑥
- Dual Conduit knockouts - Top and Bottom
- "A" Box - (2) 1/2 to 3/4" and (1) 3/4 to 1"
- "B" Box - (2) 1/2 to 3/4", (1) 1 to 1-1/4", (1) 3/4 to 1"
- (4) 8-32 x 1/2" screws for mounting controllers
- "B" Box also includes (2) 10-32 x 3/4" screws
- Does not include wire

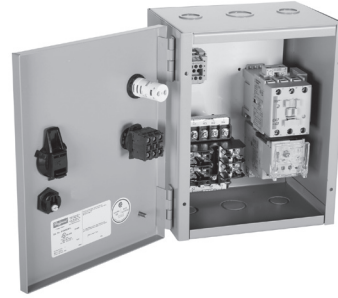

"A" Box Kit







"B" Box Kit

				"A" Box Kit			"B" Box Kit				
Catalog Number				M1-1086-A			M1-12106-B				
Optional: 35mm DIN Rail Kit with (2) 10-32 x 1/4" screws ②				SF-2 (2 inches long)			SF-3 (3 inches long)				
Dimensions ③				10" x 8" x 6" Type 1 Enclosure			12" x 10" x 6" Type 1 Enclosure				
		For use with overload		"A" Box Kit accommodates			"B" Box Kit accommodates				
For use with Controller	CEP7-ED1*	CEP7-EE*	CT7N	Use with No CPT	Use with 50VA CPT ⑤	Space for 2" DIN Rail ②	Use with No CPT	Use with 50VA CPT	Use with 100VA CPT ⑤	Space for 3" DIN Rail ②	
	Non-reversing Contactors										
CA7-9...55	~	~	~	✓	✓	✓	✓	✓	✓	✓	
CA7-60...97 ⑦	~	~	~	No	No	No	✓	N/A	✓	✓	
Reversing Contactors											
CAU7-9...37	~	~	~	✓	No	✓	✓	✓	✓	✓	
CAU7-43...55	~	~	~	No	No	No	✓	✓	✓	✓	
CAU7-60...97 ⑦	~	~	~	No	No	No	No	N/A	No	No	
Non-Reversing Starters											
CAT7-9...23	✓	✓	①	✓	✓	✓	✓	✓	✓	✓	
CAT7-30...55	✓	✓	①	✓	✓	✓	✓	✓	✓	✓	
CAT7-60...97 ⑦	N/A	✓	①	No	No	No	✓	N/A	✓	✓	
Reversing Starters											
CAU7-9...23	✓	✓	①	✓	No	✓	✓	✓	✓	✓	
CAU7-30...37	✓	✓	①	✓	No	✓	✓	✓	✓	✓	
CAU7-43...55	✓	✓	①	No	No	No	✓	✓	✓	✓	
CAU7-60...97 ⑦	N/A	No	No	No	No	No	No	No	No	No	
NEMA Sized Non-reversing Starters											
CATN7-12...16	✓	✓	①	✓	✓	✓	✓	✓	✓	✓	
CATN7-37	✓	✓	①	✓	✓	✓	✓	✓	✓	✓	
CATN7-43	✓	✓	①	✓	✓	✓	✓	✓	✓	✓	
CATN7-85	N/A	✓	①	No	No	No	✓	N/A	✓	✓	

- ① Alternatively CT7N overload relay can be used which will require CT7N-RA3 Reset Adapter. Not included in the kit. Order separately.
- ② 2" DIN rail can accommodate up to (3) V7-W4 TB's or equivalent DIN rail mount timers, relays, etc. Order kit SF-2 separately.
3" DIN rail can accommodate up to (6) V7-W4 TB's or equivalent DIN rail mount timers, relays, etc. Order kit SF-3 separately.
- ③ Enclosure designed for use with CPT with top mount secondary fuse, plus back pan mounted Ambus Fuseholder with (2) primary fuses. A CPT and the addition of extra terminal blocks or other control relay using the 2" DIN rail space may require a design change.

- ④ This enclosure is designed for use with a D7 multi-function Start/Stop as standard plus a D7D monolithic pilot light to fit the (2) 22mm knockouts provided. Additional pilot device holes will require field drilling and may interfere with the controller or the addition of a CPT or TB's.
- ⑤ (2) 22mm knockout locations are provided for one reset Kit to be located contingent on the type of controller used. See box Instruction sheet for mounting details of controller and reset kit.
- ⑥ For enclosure dimensions see page C122
- ⑦ CA7-97 and CAT7-97 will not fit in "B" Box because of wire bending space requirements. See Selection tables for box sizes starting on page C122 for dimensions.
- ⑧ The CEP7-1ERA reset adapter is a 3rd generation accessory only compatible to 3rd generation CEP7-1 overloads

Pilot Device Kits – All applications (except Kwikstarters and Explosion Proof enclosures) ❶

Kits	Description	Contact Blocks included		For Use With Enclosure...	Catalog Number
		NO	NC		
	Multi-Function Pushbutton kit ❷ START-STOP Non-illuminated, Standard for “A” and “B” Box Kits.	1	1	Type 1, 12, 3R, 4, 4X, 13	SS6-D7P
				Type 1, 12, 3R, 4, 13	SS6-D7M
	Multi-Function Pushbutton kit ❷ FORWARD-STOP-REVERSE Non-illuminated, Standard for “A” and “B” Box Kits.	2	3	Type 1, 12, 3R, 4, 4X, 13	SS5-D7P
				Type 1, 12, 3R, 4, 13	SS5-D7M
	STOP and START Two button pushbutton kit	1	1	Type 1, 12, 3R, 4, 4X, 13	SS1-D7P
				Type 1, 12, 3R, 4, 13	SS1-D7M
	FORWARD, REVERSE and STOP Three button pushbutton kit	2	3	Type 1, 12, 3R, 4, 4X, 13	SS7-D7P
				Type 1, 12, 3R, 4, 13	SS7-D7M
	HAND-OFF-AUTO selector switch kit Name plate included.	2	0	Type 1, 12, 3R, 4, 4X, 13	SS2-D7P
	Type 1, 12, 3R, 4, 13			SS2-D7M	
	FWD-OFF-REV selector switch kit Name plate included.	2	0	Type 1, 12, 3R, 4, 4X, 13	SS9-D7P
	Type 1, 12, 3R, 4, 13			SS9-D7M	
	OFF-ON selector switch kit Name plate included.	1	0	Type 1, 12, 3R, 4, 4X, 13	SS4-D7P
	Type 1, 12, 3R, 4, 13			SS4-D7M	
	Monolithic Pilot Light kit LED Lamp and lens cap Does not include nameplate	~	Type 1, 12, 3R, 4, 4X, 13	Green LED 24V AC/DC	D7D-P3N3
				Red LED 24V AC/DC	D7D-P4N3
				Green LED 120V AC	D7D-P3N5
				Red LED 120V AC	D7D-P4N5
				Green LED 240V AC	D7D-P3N7
				Red LED 240V AC	D7D-P4N7



Example of pushbutton kits on an “A” Box

❶ Pilot Device Kits do not include control wires. See instruction sheet for installation.
 ❷ Multi-function START/STOP pushbutton are standard for General Purpose Type 1(M1) dimensions A and B enclosures.

A.C. Coil Codes & Voltage Ranges ①⑤

All catalog numbers, list prices and enclosure dimensions in the previous section reflect contactors with AC coils. If necessary, add the appropriate price adder to the list price for each coil required as shown in the online catalog. Remember that reversing applications require two coils.

A.C. Coil Codes (Replace “*” in cat.# with coil code)	CA7-9 thru CA7-97 CAN7-12...85	
	50 Hz	60 Hz
24Z	24V	24V
120	110V	120V
220W	200-220V	208-240V
277	240V	277V
415	400-415V	~
480	440V	480V
600	550V	600V

D.C. Coil Codes & Voltage Ranges ①⑤

For starters with DC coils, select Coil Code from the table below. Remember that reversing applications require two coils (Price Adder x 2). Starter catalog numbers must be modified when using DC coils. For example: For **CAT7-9...55** contactors, add an “E” to catalog number for Electronic DC Coils. i.e.: CAT7-9... becomes CAT7-9E... For **CAT7-60...97** contactors, add a “D” to catalog number. i.e.: CAT7-60... becomes CAT7-60D...

D.C. Coil Codes (Replace “*” in cat.# with coil code)	⑥	⑥	④
	CA7-9E...37E CAN7-12E...37E	CA7-43E ...55E CAN7-43E	CA7-60D...97D CAN7-85D
CA7 Code	Voltage	Voltage	Voltage
12E	12VDCE	12VDCE	~
24E	24VDCE	24VDCE	~
24DD	~	~	24VDC
36E	36-48VDCE	36-48VDCE	~
48E	48-72VDCE	48-72VDCE	~
110E	110VDCE	110VDCE	~
110DD	~	~	110VDC
~	~	~	~
220E	220VDCE	220VDCE	~
250DD	~	~	250VDC

Starter Modification Codes

CAT9 AC/DC Coil Codes and Voltage Ranges ②③⑤

Electronic Coils	V	24-60V	48-130V	100-250V	250-500V
		(Replace “*” in cat.# with coil code)			
CA9-116...370	AC/DC	24W	48W	120W	480W
CA9-116-EI...370-EI	AC/DC with PLC Input	~	~	120W	480W
CA9-400-EI...750-EI		24W	48W	120W	480W
CA9-860-EI...1060-EI		~	~	120W	~
CA9-1260-EI		24W	48W	120W	480W
CA9-2050-EI...2650-EI		~	~	120W	~

① Only the most common coils are shown here. Other coil voltages may be available. Refer to Contactor Renewal Parts in Section A of this catalog, or contact your nearest Sprecher + Schuh sales office.

② Wide range coil.

③ “-EI” designates contactor coil with PLC input. Selections CA9-116...370 with “EI” requires use of control logic on terminals 1, 2, 3. CA9-400 contactors and larger include an integral switch to select use of “EI”.

④ “DD” coils are standard for CA7-60D...97D.

⑤ Reversing applications require two coils.

⑥ CA7-9E...55E electronic coils are not interchangeable with non-electronic DC or AC coils.

⑦ This coil range is 24-60V DC only.

CA7 Contactor with CEP7 Overload Relay ①③④

For use with contactor...	Amp Range	Overload Relay Code (◆)	Catalog Number (of Overload Relay)
3-Phase / Manual Reset / Class 10			
CA7-9...CA7-23	0.1...0.5	D1AB	CEP7-ED1AB
	0.2...1.0	D1BB	CEP7-ED1BB
	1.0...5.0	D1CB	CEP7-ED1CB
	3.2...16	D1DB	CEP7-ED1DB
	5.4...27	D1EB	CEP7-ED1EB
CA7-30...CA7-55	1.0...5.0	D1CD	CEP7-ED1CD
	3.6...16	D1DD	CEP7-ED1DD
	5.4...27	D1ED	CEP7-ED1ED
	9...45	D1FD	CEP7-ED1FD
3-Phase / Auto or Manual / Adjustable Trip Class 10, 15, 20 & 30			
CA7-9...CA7-23	0.1...0.5	EAB	CEP7-EEAB
	0.2...1.0	EBB	CEP7-EEBB
	1.0...5.0	ECB	CEP7-EECB
	3.2...16	EDB	CEP7-EEDB
	5.4...27	EEB	CEP7-EEEB
CA7-30...CA7-55	1.0...5.0	ECD	CEP7-EECD
	3.2...16	EDD	CEP7-EEDD
	5.4...27	EED	CEP7-EEED
	9...45	efd	CEP7-EEFD
CA7-55	11...55	EQD	CEP7-EEQD
CA7-60...CA7-97	5.4...27	EEE	CEP7-EEEF
	9...45	EFE	CEP7-EEFE
	18...90	EGE	CEP7-EEGE
	60...120	EVE	CEP7-EEVE

Large Amp CEP7 Solid State Overload Relays, Automatic or Manual Adjustable Trip Class ①②③④

Directly Mounts to Contactor... ②	Adj. Range (A)	Overload Relay Code (◆)	CT Ratio	Catalog Number (of Overload Relay)
Automatic or Manual Reset for 3-Phase Applications Adjustable Trip Class 10, 15, 20 & 30				
CA9-116...146	30...150	EHJ	150:5	CEP7-EEHJ
CA9-190...205	40...200	EJJ	200:5	CEP7-EEJJ
CA9-265...305		CT3	300:5	③
CA9-370...580		CT6	600:5	③
CA9-750...1060		~		Refer to Factory

Special Notes:
Wye-Delta Starters - First multiply motor full load current by 58%. Then, using this figure, select appropriate Overload Relay Code from tables above.
Part Winding Starters - First multiply motor full load current by 50%. Then, using this figure, select appropriate Overload Relay Code from tables above.
Variable Frequency Drives - CEP7 solid state overload relays cannot be utilized on VFDs or Softstarters with Braking option.

CEP7 Gen 2 Obsolete. See page C105.1

CB7 Contactor with CEP7 Overload Relay

For use with contactor...	Amp Range	Overload Relay Code (◆)	Catalog Number (of Overload Relay)
1-Phase / Automatic or Manual Reset / Class 10			
CA7-9...CA7-23	1.0...5.0	EPB	CEP7S-EEPB
	3.2...16	ERB	CEP7S-EERB
	5.4...27	ESB	CEP7S-EESB
CA7-30...CA7-43	9...45	ETD	CEP7S-EETD
CA7-60...CA7-97	18...90	EUE	CEP7S-EEUE

① 3-phase CEP7 units are only designed for 3Ø applications. Single phase CEP7S units are only designed for 1Ø applications.
 ② This reference is not intended to be a guide for selecting contactors. Size overload relays using the full load current of the motor.
 ③ The reset time of a CEP7 set in the automatic mode is approximately 180 seconds.

④ CEP7 Overload relays do not work with Variable Frequency Drives or any Sprecher + Schuh Softstarter with braking options.
 ⑤ Utilizes UL approved Current Transformers and a CEP7-EECB overload relay. Refer to page B13 for current setting guidance. For CE approved Current Transformers refer to factory.

Starter Modification Codes

CA7 Contactor with CEP7 Overload Relay ③④

For use with contactor...	Amp Range	Overload Relay Code (◆)	Catalog Number (of Overload Relay)
1-Phase & 3-Phase / Manual reset / Class 10&20			
CA7-9...CA7-23	0.1...0.5	1EAB	CEP7-1EEAB
	0.2...1.0	1EBB	CEP7-1EEBB
	1.0...5.0	1ECB	CEP7-1EECB
	3.2...16	1EDB	CEP7-1EEDB
	5.4...27	1EEB	CEP7-1EEEB
CA7-30...CA7-55	1.0...5.0	FCP	CEP7-1EFCP ❶
	3.2...16	FDP	CEP7-1EFDP ❶
	5.4...27	1EED	CEP7-1EEED
	11...55	1EFD	CEP7-1EEFD
CA7-60...97	20...100	1EGE	CEP7-1EEGE
1-Phase & 3-Phase / Auto or Manual / Adj. Trip Class 10...30			
CA7-9...CA7-23	0.1...0.5	FAB	CEP7-1EFAB
	0.2...1.0	FBB	CEP7-1EFBB
	1.0...5.0	FCB	CEP7-1EFGB
	3.2...16	FDB	CEP7-1EFDB
	5.4...27	FEB	CEP7-1EFEB
CA7-30...CA7-55	1.0...5.0	FCP	CEP7-1EFCP ❶
	3.2...16	FDP	CEP7-1EFDP ❶
	5.4...27	FED	CEP7-1EFED
	11...55	FFD	CEP7-1EFFD
CA7-55	11...55	FFD	CEP7-1EFFD
CA7-60...CA7-97	5.4...27	FEP	CEP7-1EFEP ❶
	11...55	FFP	CEP7-1EFFP ❶
	20...100	FGE	CEP7-1EFGE

- ❶ Engineered solution is a pass-thru model overload. No direct contactor mounting for this selection is available within the CEP7-1EE/1EF series.
- ❷ This reference is not intended to be a guide for selecting contactors. Size overload relays using the full load current of the motor.
- ❸ The reset time of a CEP7 set in the automatic mode is approximately 180 seconds.

Large Amp CEP7 Solid State Overload Relays, Automatic or Manual Adjustable Trip Class ②③④

Directly Mounts to Contactor... ❷	Adj. Range (A)	Overload Relay Code (◆)	CT Ratio	Catalog Number (of Overload Relay)
Automatic or Manual Reset for 3-Phase Applications Adjustable Trip Class 10, 15, 20 & 30				
CA9-116...146	30...150	9IP	150:5	CEP7-EEHJ
CA9-190...205	40...200	9IP	200:5	CEP7-EEJJ
CA9-265...305		CT3	300:5	❸
CA9-370...580		CT6	600:5	❸
CA9-750...1060		~		Refer to Factory

Special Notes:

Wye-Delta Starters - First multiply motor full load current by 58%. Then, using this figure, select appropriate Overload Relay Code from tables above.

Part Winding Starters - First multiply motor full load current by 50%. Then, using this figure, select appropriate Overload Relay Code from tables above.

Variable Frequency Drives - CEP7 solid state overload relays cannot be utilized on VFDs or Softstarters with Braking option.

- ❹ CEP7 Overload relays do not work with Variable Frequency Drives or any Sprecher + Schuh Softstarter with braking options.
- ❺ Utilizes UL approved Current Transformers and a CEP7-1EF_Z overload relay. For CE approved Current Transformers – refer to factory.

Intelli-button Reset Kit Factory Modification

The CEP7-ERID Intelli-button plus your choice of side-mounted module can be ordered as a factory modification, installed in any control panel built by Sprecher + Schuh that contains a CEP7-EE_ overload relay. Just add the kit suffix shown below to the end of the starter catalog number. For example, CAT7-9-120-EEB-G0 becomes CAT7-9-120-EEB-G0-IB2

Starter Modification Codes

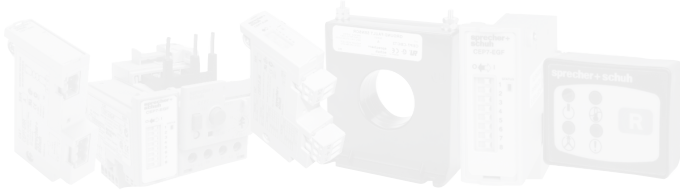

CEP7-ERID + Side Mount Module...	Add to end of Catalog Number	Kit includes...
Remote Reset Only	-IB1	CEP7-ERID CEP7-ERR
Jam and Remote Reset	-IB2	CEP7-ERID CEP7-EJM (B)
Thermistor Relay and Remote Reset	-IB3	CEP7-ERID CEP7-ERT CEP7-EGF
Ground Fault and Remote Reset	-IB5	CEP7-ERID CEP7-EGF CEP7-CBCT1 (45A)
	-IB6	CEP7-ERID CEP7-EGF CEP7-CBCT3 (180A)
	-IB7	CEP7-ERID CEP7-EGF CEP7-CBCT4 (420A)
	-IB8	CEP7-ERID CEP7-EGJ CEP7-CBCT1 (45A)
Ground Fault and Jam and Remote Reset Module	-IB9	CEP7-ERID CEP7-EGJ CEP7-CBCT2 (90A)
	-IB10	CEP7-ERID CEP7-EGJ CEP7-CBCT3 (180A)
	-IB11	CEP7-ERID CEP7-EGJ CEP7-CBCT4 (420A)

CEP7 Gen 2 Obsolete

CA7 Starters with optional CT7N Bimetallic Overload Relay ①

Directly Mounts to Contactor...	Amp Range	Overload Relay Code (◆)	Catalog Number (of Overload Relay used)
CA7-9... CA7-23 Frame "A"	0.10...0.16	AA16	CT7N-23-A16
	0.16...0.25	AA25	CT7N-23-A25
	0.25...0.40	AA40	CT7N-23-A40
	0.35...0.50	AA50	CT7N-23-A50
	0.45...0.63	AA63	CT7N-23-A63
	0.55...0.80	AA80	CT7N-23-A80
	0.75...1.0	AB10	CT7N-23-B10
	0.90...1.3	AB13	CT7N-23-B13
	1.1...1.6	AB16	CT7N-23-B16
	1.4...2.0	AB20	CT7N-23-B20
	1.8...2.5	AB25	CT7N-23-B25
	2.3...3.2	AB32	CT7N-23-B32
	2.9...4.0	AB40	CT7N-23-B40
	3.5...4.8	AB48	CT7N-23-B48
	4.5...6.3	AB63	CT7N-23-B63
	5.5...7.5	AB75	CT7N-23-B75
	7.2...10	AC10	CT7N-23-C10
	9.0...12.5	AC12	CT7N-23-C12
	11.3...16	AC16	CT7N-23-C16
	15...20	AC20	CT7N-23-C20
17.5...21.5	AC21	CT7N-23-C21	
21...25	AC25	CT7N-23-C25	
CA7-30... CA7-37 Frame "B"	15...20	BC20	CT7N-37-C20
	17.5...21.5	BC21	CT7N-37-C21
	21...25	BC25	CT7N-37-C25
	24.5...30	BC30	CT7N-37-C30
	29...36	BC36	CT7N-37-C36
CA7-43...55 Frame "C"	33...38	BC38	CT7N-37-C38
	17...25	CC25	CT7N-43-C25
	24.5...36	CC36	CT7N-43-C36
CA7-60... CA7-97 Frame "D"	35...47	CC47	CT7N-43-C47
	45...60	CC60	CT7N-55-C60
CA7-60... CA7-97 Frame "D"	35...47	DC47	CT7N-85-C47
	45...60	DC60	CT7N-85-C60
	58...75	DC75	CT7N-85-C75
	72...90	DC90	CT7N-85-C90
CA7-60... CA7-97 Frame "D"	85...97	DC97	CT7N-97-C97

Special Notes:

Wye-Delta Starters - First multiply motor full load current by 58%. Then, using this figure, select appropriate Overload Relay Code from tables above.

Part Winding Starters - First multiply motor full load current by 50%. Then, using this figure, select appropriate Overload Relay Code from tables above.

① Separately mounted overload is available. See Section B.

Modifications or Special Feature ②	Change Last Digit (0) in Catalog Number To:
Pilot Devices In Cover or Flange	
"Start-Stop" Pushbutton	3
"On-Off" Pushbutton	4
"Emergency Stop" Pushbutton - Twist to Release ③	9
"Hand-Auto" Selector Switch	5
"Off-On" Selector Switch	6
"Hand-Off-Auto" Selector Switch	7
Pilot Light Only ①	1
Pilot Lights Only (2) ①	2
Pilot light w/ "Start-Stop" Pushbutton ①	13
Pilot Light w/ "On-Off" Pushbutton ①	14
Pilot Light w/ "Hand-Auto" Selector Switch ①	15
Pilot Light w/ "Off-On" Selector Switch ①	16
Pilot Light w/ "Hand-Off-Auto" Selector Switch ①	17
Reversing "For-Stop-Rev"- Pushbutton	3
"Up-Stop-Down" Pushbutton	4
"Open-Stop-Close" Pushbutton	5
Multi-Speed "High-Stop-Low" Pushbutton	3
"Fast-Stop-Slow" Pushbutton	4
Reversing "For-Off-Rev" Selector Switch	6
"Up-Off-Down" Selector Switch	7
"Open-Off-Close" Selector Switch	8
Multi-Speed "High-Off-Low" Selector Switch	5
"Fast-Off-Slow" Selector Switch	6
Reversing Pilot Lights (2) w/ "For-Stop-Rev" Pushbutton ①	23
Pilot Lights (2) w/ "Up-Stop-Down" Pushbutton ①	24
Pilot Lights (2) w/ "Open-Stop-Close Pushbutton ①	25
Multi-Speed Pilot Lights (2) w/ "High-Stop-Low" Pushbutton ①	23
Pilot Lights (2) w/ "Fast-Stop-Slow" Pushbutton ①	24
Reversing Pilot Lights (2) w/ "For-Off-Rev" Selector Switch ①	26
Pilot Lights (2) w/ "Up-Off-Down" Selector Switch ①	27
Pilot Lights (2) w/ "Open-Off-Close Selector Switch ①	28
Multi-Speed Pilot Lights (2) w/ "High-Off-Low" Selector Switch ①	25
Pilot Lights (2) w/ "Fast-Off-Slow" Selector Switch ①	26

Ordering Instructions

Change base **Catalog Number** according to instructions at top of column 2. Example: To Add a "Start-Stop" Pushbutton: change **CAT7-30-*-*♦-G0** to **CAT7-30-*-*♦-G3**

- ① Pilot Lights may be applied with 24VAC/DC, 120VAC or 240VAC control circuit. Pilot Lights with 380 VAC...575VAC require a control circuit transformer.
- ② Modifications may change dimension of starter enclosure.
- ③ Emergency Stop pushbutton includes inscription ring D7-15YSE112. For other selections from page H68 refer to factory.

Modifications or Special Feature ⑤		ADD Suffix to Catalog Number	Enclosure Type
Additional Auxiliary Contacts ⑥			
1 N.O. 1 N.C.		L10 L01	All
1 N.O. & 1 N.C. 2 N.O. 2 N.C.		L11 L20 L02	All
1 NO + 2 NC Auxiliary 2 NO + 1 NC Auxiliary 3 NO Auxiliaries 3 NC Auxiliaries		L12 L21 L30 L03	All
2 N.O. & 2 N.C. 1 NO + 3 NC Auxiliary 3 NO + 1 NC Auxiliary 4 NO Auxiliaries 4 NC Auxiliaries		L22 L13 L31 L40 L04	All
Alternate Auxiliary Contact Arrangements			
1 N.C. in lieu of standard 1 N.O. (on CAT7)		LX1	All
2 N.C. in lieu of standard 2 N.O. (on CAUT7)		LX2	
Control Circuit Transformer (with fused primary & secondary)			
	Primary Volts	Secondary Volts	Replace (*) in catalog # with following codes ②④
Standard Capacity ⑤	208	120	Type 1, 12, 3R, 4,4X Open
	240	120	
	480	120	
	600	120	
	380	110	
	240	24	Type 7/9
	480	24	
	600	24	
	380	24	
	208	24	
50 Watt Extra Capacity	120	24	Type 1, 12, 3R, 4,4X Open
	277	120	
	208	120	Type 7/9
	240	120	
	480	120	
	600	120	
240	24	Type 1, 12, 3R, 4,4X Open	
480	24		
100 Watt Extra Capacity	208	120	Type 1, 12, 3R, 4,4X Open
	240	120	
	480	120	
	600	120	Type 7/9
	240	24	
	480	24	
	600	24	
Special Voltage Transformer - Add suffix F/A to end of catalog # ①			All, Open
For applications requiring more than 100 Watt extra capacity			

Ordering Instructions

Change base **Catalog Number** according to instructions in column 2. Example: To Add a Control Circuit Transformer (480/120) and additional NO/NC auxiliaries: change **CAT7-30-✳-◆-GO_** to **CAT7-30-XC-◆-GO-L11**.

Note: Separate multiple modification suffixes with a hyphen (-).

- ① Factory assigned.
- ② Coil will be factory selected based on transformer secondary.
- ③ See page C112 for detail specifications for Control Circuit Transformer.
- ④ Refer to factory for pricing on larger oversized control circuit transformer selections.
- ⑤ Modifications may change dimension of starter enclosure.
- ⑥ Auxiliary addition is per contactor. Quantity is double for reversing applications.

Modifications or Special Feature ②	Power Supply					Replace (*) in catalog # with following codes	Enclosure Type
	Rating (W)	Input V AC	Output V DC	Output Amps			
				@ 40°C	@ 60°C		
AC to DC Output Power Supplies							
1-Phase Standard Capacity (CA7-9E...55E)							
Power Supply (with no CPT)	72	115	24	2	1.5	PS1P	Open All
Power Supply (with no CPT)	72	230	24	2	1.5	PS1E	
Power Supply w/CPT @ 208 VAC Primary	72	115	24	2	1.5	PS1XA	
Power Supply w/CPT @ 230 VAC Primary						PS1XB	
Power Supply w/CPT @ 460 VAC Primary						PS1XC	
Power Supply w/CPT @ 575 VAC Primary						PS1XD	
1-Phase Standard Capacity (CA7-60D...97D)							
Power Supply (with no CPT)	336	115	24	14	10	PS4P	Open All
Power Supply (with no CPT)	336	230	24	14	10	PS4E	
Power Supply w/CPT @ 208 VAC Primary	336	115	24	14	10	PS4XA	
Power Supply w/CPT @ 230 VAC Primary						PS4XB	
Power Supply w/CPT @ 460 VAC Primary						PS4XC	
Power Supply w/CPT @ 575 VAC Primary						PS4XD	
1-Phase 90W Extra Capacity (CA7-9E...55E)							
Power Supply (with no CPT)	120	115	24	5	4	PS2P	Open All
Power Supply (with no CPT)	120	230	24	5	4	PS2E	
Power Supply w/CPT @ 208 VAC Primary	120	115	24	5	4	PS2XA	
Power Supply w/CPT @ 230 VAC Primary						PS2XB	
Power Supply w/CPT @ 460 VAC Primary						PS2XC	
Power Supply w/CPT @ 575 VAC Primary						PS2XD	
2-Phase Standard Capacity (CA7-9E...55E)							
Power Supply @ 230 VAC Primary	120	230	24	5	4	PS6B	Open All
Power Supply @ 460 VAC Primary	120	460	24	5	4	PS6C	
2-Phase Standard Capacity (CA7-60D...97D)							
Power Supply @ 230 VAC Primary	336	230	24	7.5	5	PS7B	Open All
Power Supply @ 460 VAC Primary	336	460	24	7.5	5	PS7C	
For applications requiring extra capacity on either device, please refer to factory							
CR17E-* Electronic Interface Module for use with CA7-9...CA7-97: Interface between the DC control signal from a PLC and the AC operating mechanism of the contactor. <ul style="list-style-type: none"> Eliminates the need for a power supply-current draw is 10 to 15 mA across a voltage range of 12-48V DC Requires no additional surge suppression for the coils Must have output voltage 110...240V AC Add Suffix to end of catalog number: for example change CAT7-30-*-◆-GO to CAT7-30-*-◆-GO-JE 						add Suffix to end of Catalog Number -JE	Open All

Ordering Instructions

Replace * in base **Catalog Number** with Power Supply code.
 Example: To Add a Standard Capacity Power Supply with Control Circuit Transformer (480/120):
 change **CAT7-30E-*-◆-GO** to **CAT7-30E-PS1XC-◆-GO**.

- ① Not applicable for Series CA9 Starters. CAT9 Starter applications should strongly consider the use of the "EI" functionality included in the CA9-116...1060-EI Contactors. The optional electronic interface selection allows the CA9 contactor to be switched from a PLC or other low-level signal source (15...33V DC) without the need of an interposing relay. The current burden of the interface is 15 mA maximum.
- ② Modifications may change dimension of starter enclosure.

Modifications or Special Feature ⑦	ADD Suffix to Catalog Number	Enclosure Type
Other modifications		
Fused Control Circuit for separate or common control ⑥ - 1 Fuse - 2 Fuses	F1 F2	All, Open All, Open
Surge Suppressor - RC Link	RC	All, Open
Surge Suppressor - Varistor	RV	All, Open
Surge Suppressor - Diode	RD	All, Open
Unwired Terminal Blocks Specify quantity (▼).	- ▼TB	All
Control Relay Limited to one per controller-8 pole maximum, Specify pole arrangement and voltage ⑤	F/A ①	All, Open
Timing Relay Limited to one per controller-specify "On" or "Off" delay. Voltage will be same as coil voltage	F/A ①	All, Open
Compelling Relay ② ⑤	F/A ①	All, Open
Progressive or Decelerating Relay ② ⑤	F/A ①	All, Open
Omit Automatic Alternator ③	F/A ①	All, Open
Back Spin Timer ④	F/A ①	All, Open
Program Timer (24 hour) ④	F/A ①	All, Open
Fireman Damper Control Option		
HVAC Enclosed Starter Fireman Damper Option - 24 VAC/DC - 120 VAC/DC	FD24 FD120	Type 1
		Non-Combination
		Fusible
		Non-Fusible
		Thermal Magnetic
		Type 3R
Non-Combination		
Fusible		
Non-Fusible		
Thermal Magnetic		

Ordering Instructions

Change base catalog number according to instructions at top of column 2 or 3.
Example: To Add a "Start-Stop" Pushbutton, Control Circuit Transformer (480/120) and RC Link: change **CAT7-30-*-◆-G0** to **CAT7-30-XC-◆-G3-RC**.
Note: Separate multiple modification suffixes with a hyphen (-).

- ① Factory assigned.
- ② For Multi-speed controllers.
- ③ For Duplex Pump controllers.
- ④ For Pump Panel controllers.
- ⑤ If controller has a Control Circuit Transformer, select transformer with additional capacity for relay required.
- ⑥ CPT and power supply modification includes fused control circuit protection.
- ⑦ Modifications may change dimension of starter enclosure.

Modifications or Special Feature ③	ADD Suffix to Catalog Number	Enclosure Type
Meters		
Ammeter - Single Phase	AM1	All, Open
Ammeter - Three Phase (includes switch)	AM3	
Voltmeter - Single Phase	VM1	
Voltmeter - Three Phase (includes switch)	VM3	
Wattmeter	WM	
Elapsed Time Meter	ETM	
Enclosures		
Space Heater (with N.C. interlock)	HTR	Type 1, 12, 3R, 4, 4X
Breather and Drain	BD	Type 7/9
Service Identification Nameplate	F/A ❶	All
Miscellaneous		
Lightning Arrester ②	LA	All, Open
Surge Capacitor ②	SC	
Phase Monitor Relay	F/A ❶	
UL508A Panel Label	UL	Type 1, 12, 3R, 4, 4X
UL1203 Panel Label (includes 508A)	ULX	Type 7/9

Panel Shop Certifications

Sprecher + Schuh is an ISO9001 company. Our panel shops are UL and ATEX Certified.

Please refer to factory for specifications and label options for the following panel certifications.

UL508A or SUSE label: Most starter assemblies can be supplied with a UL508A 'Industrial Control Panel' label. Combination starters can be supplied with Suitable for Service Entrance (SUSE) label. The need for a UL508A or SUSE label must be identified at the time of quotation as well as on the purchase order. The need for a UL508A label may not change the components we would normally use but we must consider all possible requirements at the time we are developing the bill-of-material to be referenced at the time of order entry. Failure to identify the need for a UL508A label or SUSE label at the time of quotation may result in change notice price adders.

ATEX Certification: A requirement for ATEX certification MUST be identified at the time of quotation as well as on the purchase order. ATEX certification of a Type 7/9 explosion proof enclosure definitely requires all conduit and cover openings to be drilled by the enclosure manufacturer. Further, all pilot devices and equipment to be installed must be identified as it controls the heat dissipation which is an ATEX certification requirement. Absolutely no field modification of an ATEX certified starter assembly is allowed. Failure to identify the need for an ATEX certification at the time of quotation and order entry may result in 100% cancelation or re-stocking charge since a new enclosure will be required.

UL1203 Certification: The UL1203 label for explosion proof starters and panels encompasses the UL508A certification. This means all components in a UL1203 labeled panel must first comply with UL508A, and all components in the panel must have a UL label in some form, including the wiring. A special name plate and UL508A label are applied to the panel or starter. A panel is not UL1203 certified unless both label and name plate are present. Contact customquotes@sprecherschuh.com for more information on UL1203 certified panels.

Ordering Instructions

Change base catalog number according to instructions at top of column 2.
Example: To add an Elapsed Time Meter and Breather Drain to an explosion-proof starter, change **CAT7-30-*-*♦-ED** to **CAT7-30-*-*♦-ED-ETM-BD**.
Note: Separate multiple modification suffixes with a hyphen (-).

- ❶ Factory assigned.
- ❷ For Pump Panel controllers.
- ❸ Modifications may change dimension of starter enclosure.

Contactors (Relay) Coil Data

Device	Coil Consumption		Coil Consumption				Minimum Recommended Transformer
	DC Watts		AC				
	Inrush	Sealed	Inrush (pick-up)		Sealed (holding)		VA
			VA	Watts	VA	Watts	VA
CA8-9, CA8-12	-	-	35	32	5	1.8	50
CA8-09C, CA8-12C	3.0 cold / 2.6 warm	3.0 cold / 2.6 warm	-	-	-	-	-
CA7-9, CA7-12, CA7-16	-	-	75	50-60	9.5	2.7	50
CA7-9E, CA7-12E, CA7-16E, CA7-23E	10 avg. / 17 peak	1.7	-	-	-	-	-
CA7-23	-	-	105	60-70	12.3	3.1	50
CA7-30, CA7-37	-	-	105	70	12.3	3.1	50
CA7-30E, CA7-37E	10 avg. / 17 peak	1.7	-	-	-	-	-
CAL7-30, CA7-40	-	-	135	90-100	13.3	3.3	75
CA7-43, CA7-55	-	-	135	90-100	13.3	3.3	75
CA7-40E, CA7-43E, CA7-55E	16 avg. / 25 peak	2.5	-	-	-	-	-
CA7-60, CA7-72, CA7-85	-	-	235	110	19	6.5	100
CAL7-60, CA7-90, CA7-97	-	-	400	240	24	9	200
CA7-60D, CA7-72D, CA7-85D, CA7-97D	200	4.5	-	-	-	-	-
CA7-90D	325	5.5	-	-	-	-	-
CA9-116, CA9-146							100
CA9-190, CA9-205							100
CA9-265, CA9-305, CA9-370							100
CA9-400, CA9-460							200
CA9-580, CA9-750							200
CA9-860, CA9-1060							300
CA9-1260							200
CA9-2050, CA9-2650							300

See section A

Control Circuit Transformer Voltage Specifications

Factory Modification Code	Factory Wired Connection		Voltage Taps Available	
	Primary	Secondary	Primary	Secondary
XA	208	120	208/230/460	115
XB	240	120	240/480	120
XC	480	120	240/480	120
XD	600	120	575/600	115/120
XE	240	24	240/480	24
XF	480	24	240/480	24
XG	380	110	380/400/415	110/220
XH	Must specify tap	115	208/230/460	115
XJ	600	24	600	12/24
XK	380	24	480/380/277/240/208	24
XL	415	24	480/415/400	24/120
XM	Must specify tap	24/115	208/230/460	24/115
XN	400	24	480/415/400	24/120
XO	208	24	208/230/460	24/115
XP	120	24	120/240	24

- ① 50Hz, 60Hz or 50/60Hz except CA7 which is 60Hz.
- ② For AC coils.
- ③ The "VA" values shown are the minimum requirement to energize one contactor. For multiple contactors and/or additional control circuit devices (burden) refer to control circuit transformer manufacturer's selection criteria.
- ④ Modification codes in Gray are Special Order. Contact a Sprecher + Schuh representative.

Starters & Enclosed Products

Motor Starters - Non-Reversing

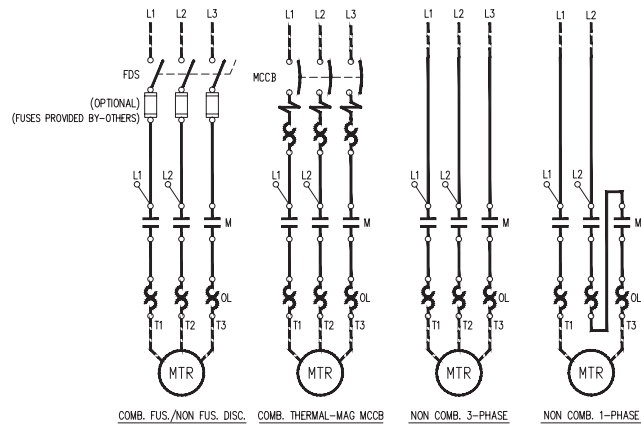
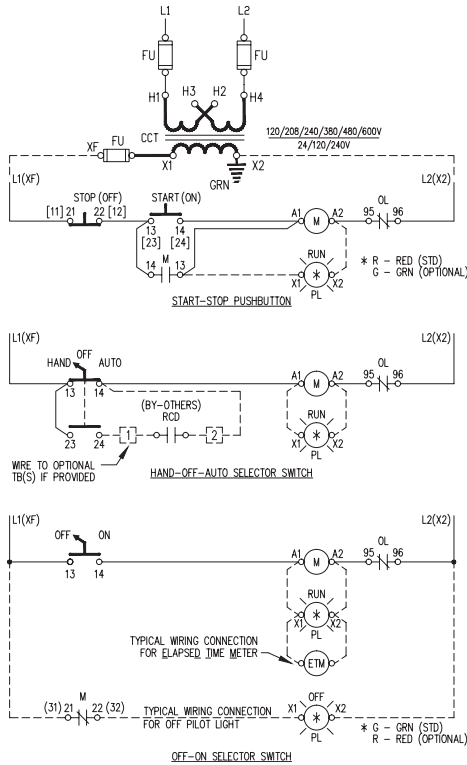

NOTES:

- 1) X2 TERMINAL GROUNDED AS STANDARD, REMOVE GROUND IF NOT REQUIRED.
- 2) RCD: STANDS FOR REMOTE CONTROL DEVICE BY CUSTOMER.
- 3) [] : FOR MULTIFUNCTION TERMINAL NUMBERS.
- 4) () : FOR ALT. AUX. CONTACT TERMINAL NUMBERS.

Motor Starters - Non-Reversing (with Current Transformers)

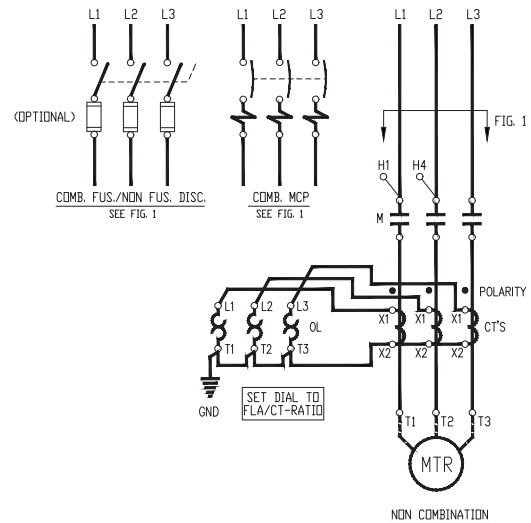
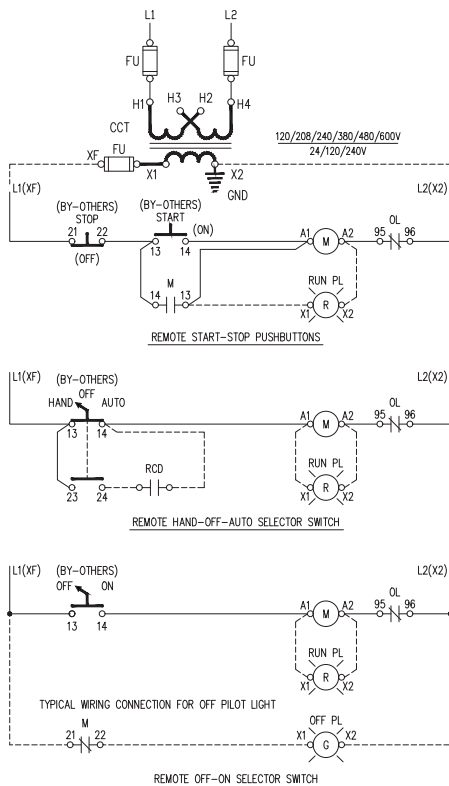

NOTES:

- 1) RCD: STANDS FOR REMOTE CONTROL DEVICE BY CUSTOMER.
- 2) X2 TERMINAL GROUNDED AS STANDARD, REMOVE GROUND IF NOT REQUIRED.
- 3) REFER TO PAGE B13 FOR CURRENT SETTING GUIDANCE

Motor Starters - Reversing (three phase & single phase reconnectable)

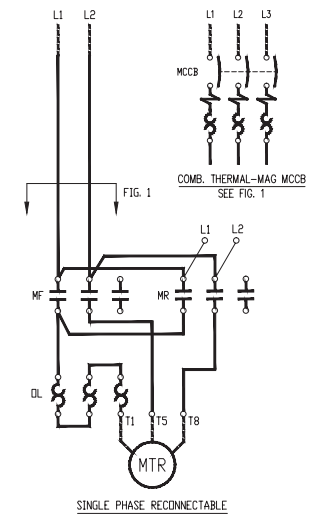
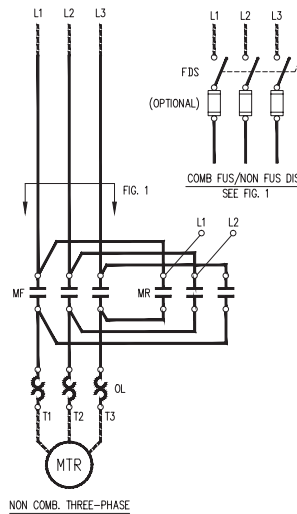
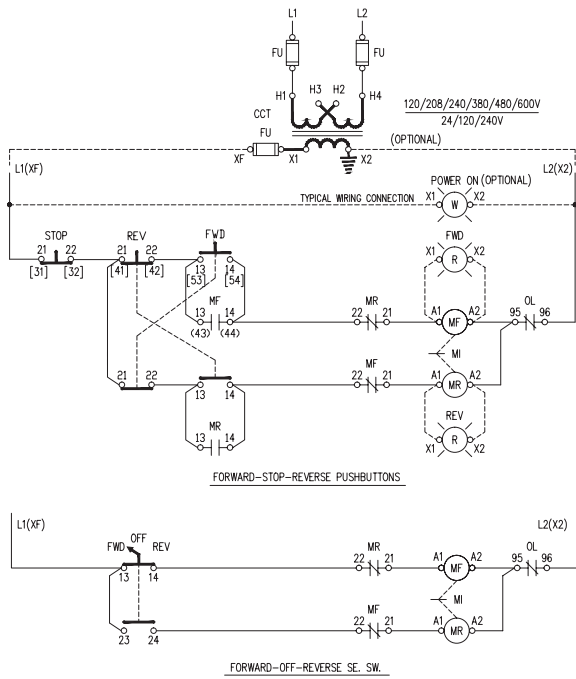

NOTES:
 1) X2 TERMINAL GROUNDED AS STANDARD. REMOVE IF NOT REQUIRED.
 2) MI: STANDS FOR MECHANICAL INTERLOCK
 3) TERMINAL NUMBERS IN () APPLIES ONLY ON CA7-30...97

Motor Starters - Reversing (single phase series & parallel winding)

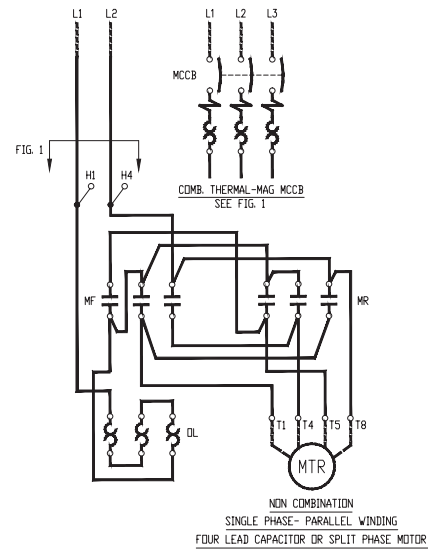
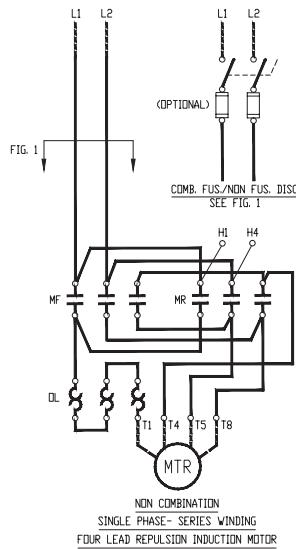
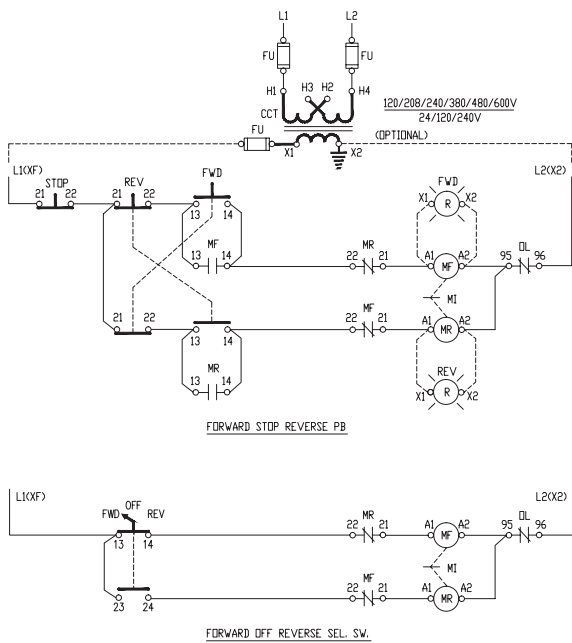

NOTES:
 1) X2 TERMINAL GROUNDED AS STANDARD. REMOVE IF NOT REQUIRED.
 2) MI STANDS FOR MECHANICAL INTERLOCK.

Reduced Voltage Starters - Autotransformer

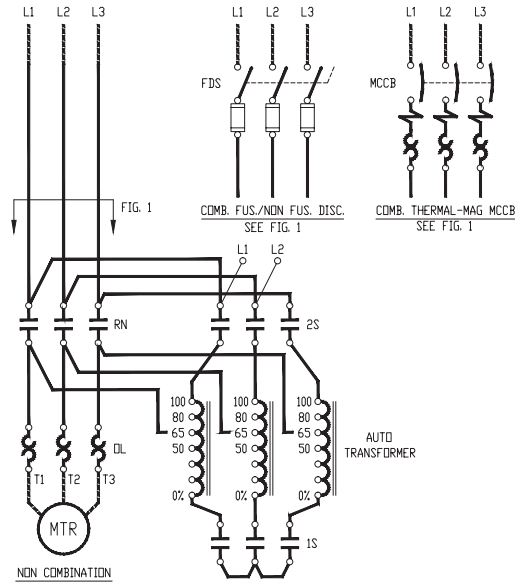
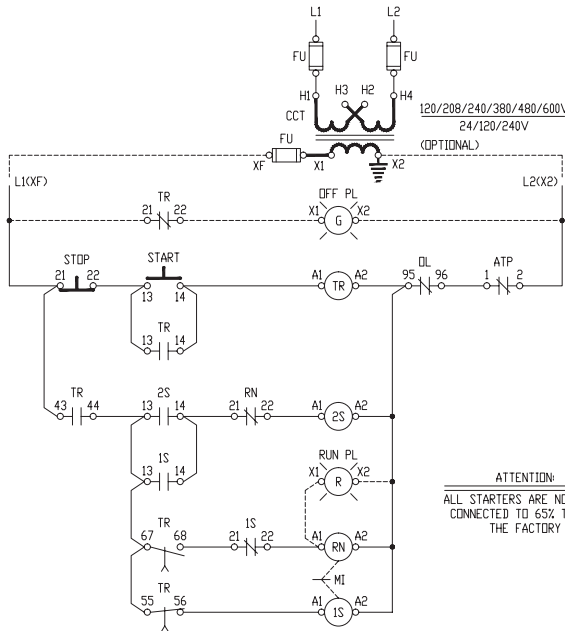

ATTENTION:
ALL STARTERS ARE NORMALLY
CONNECTED TO 65% TAP AT
THE FACTORY

- NOTES:
1. ATP: STANDS FOR AUTO TRANSFORMER THERMAL PROTECTION.
 2. X2 TERMINAL GROUNDED AS STANDARD, REMOVE IF NOT REQUIRED.
 3. MI STANDS FOR MECHANICAL INTERLOCK.
 4. TIMING RELAY TR: CS7-22E+CZE7-30S.

Reduced Voltage Starters - Part Winding

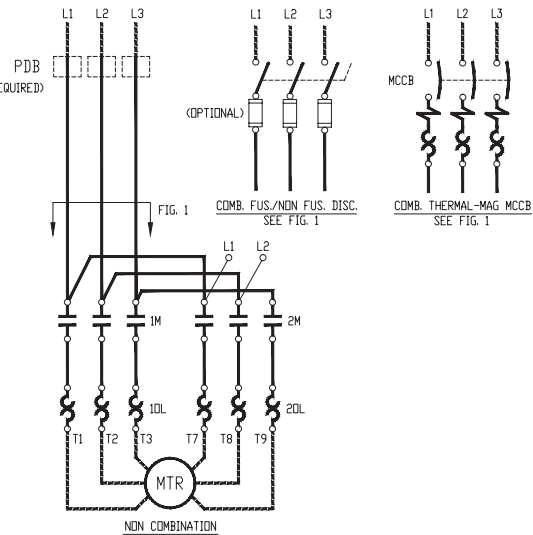
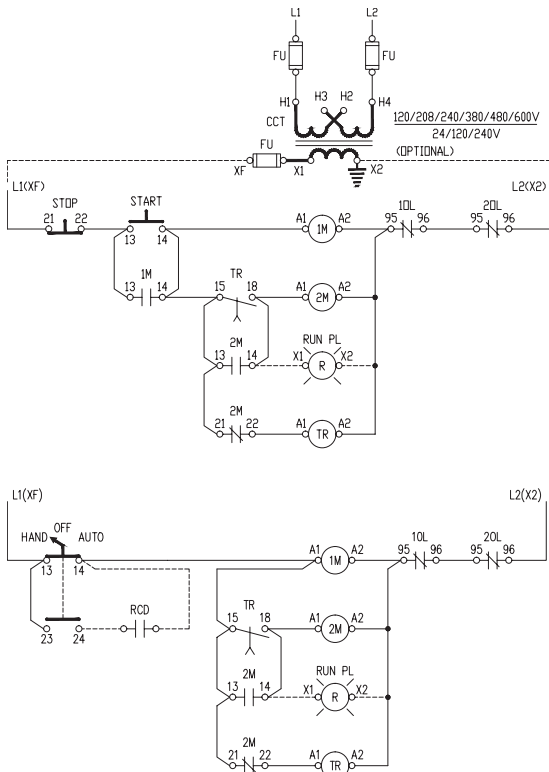

- NOTES:
1. OVERLOAD RELAY SETTING: MOTOR FLC X 0.5.
 2. X2 TERMINAL GROUNDED AS STANDARD, REMOVE IF NOT REQUIRED.
 3. TIME DELAY RELAY TR TO BE SET TO SHORTEST TIME POSSIBLE; MAX. 3 SECONDS.
- TIMING RELAY TR: RZ7-FSA3

Reduced Voltage Starters - Wye Delta (Open Transition)

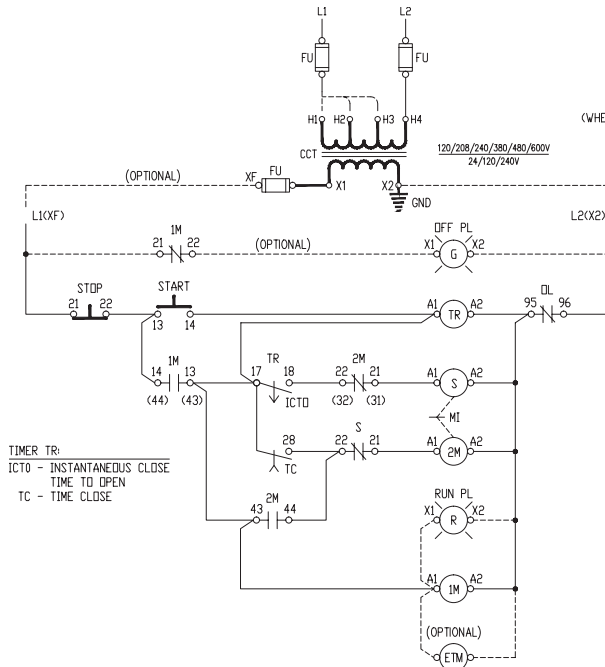

- NOTES:
- 1). OVERLOAD RELAY SETTING: MOTOR FLC X 0.58.
 - 2). X2 TERMINAL GROUNDED AS STANDARD, REMOVE IF NOT REQUIRED.
 - 3). MI STANDS FOR MECHANICAL INTERLOCK.
 - 4). TIMING RELAY TR: RZ7-FSY2 WYE DELTA TIMER.

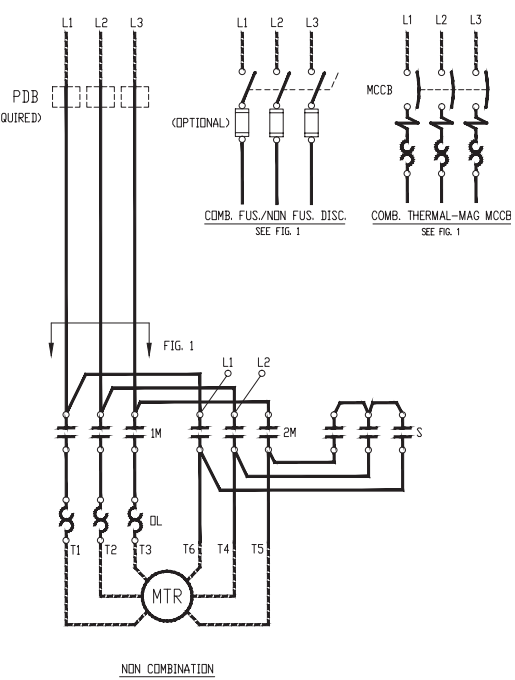

Reduced Voltage Starters - Wye Delta (Closed Transition)

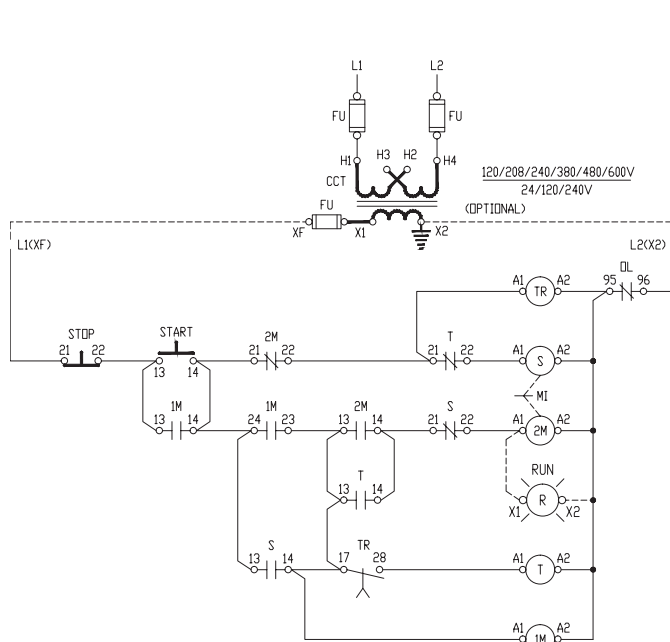

- NOTES:
- 1). OVERLOAD RELAY SETTING: MOTOR FLC X 0.58.
 - 2). X2 TERMINAL GROUNDED AS STANDARD, REMOVE IF NOT REQUIRED.
 - 3). MI STANDS FOR MECHANICAL INTERLOCK.
 - 4). TIMING RELAY TR: RZ7-FSY2D

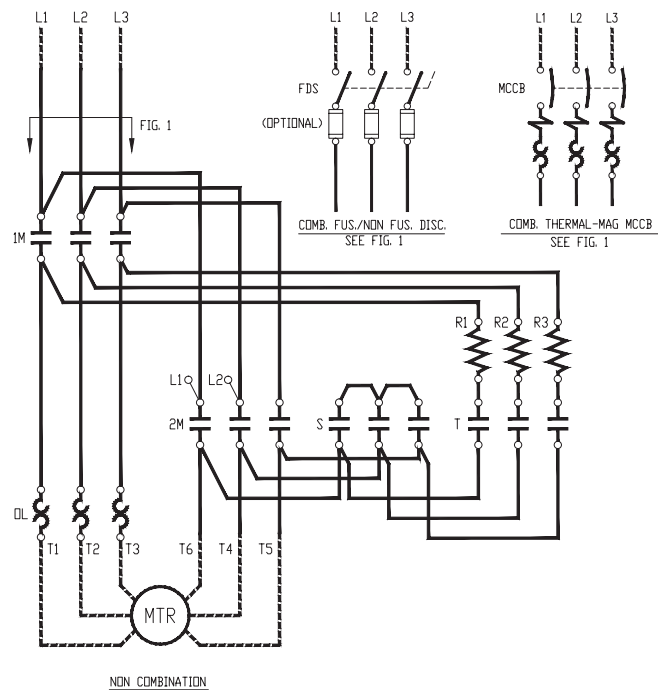

Typical Hydraulic Elevator Two-Contactor Wye-Delta Starter

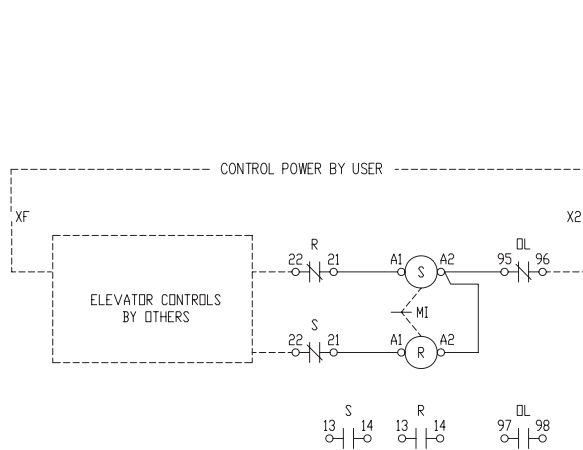

NOTES:

- 1). MI: STANDS FOR MECHANICAL INTERLOCK.
- 2). R: STANDS FOR RUN CONTACTOR.
- 3). S: STANDS FOR STAR (SHORTING) CONTACTOR.
- 4). OVERLOAD RELAY SETTING: MOTOR FLC X 0.58.

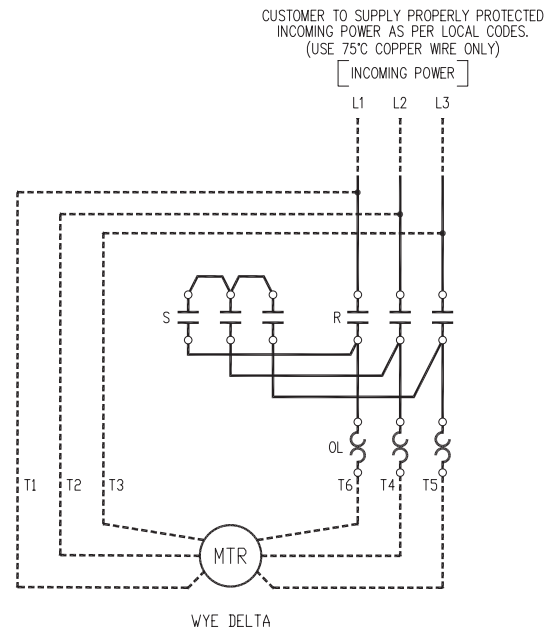

CUSTOMER TO SUPPLY PROPERLY PROTECTED INCOMING POWER AS PER LOCAL CODES. (USE 75°C COPPER WIRE ONLY)

C
Starters & Enclosed Products

Multi Speed - One Reconnectable Winding (Selective Control)

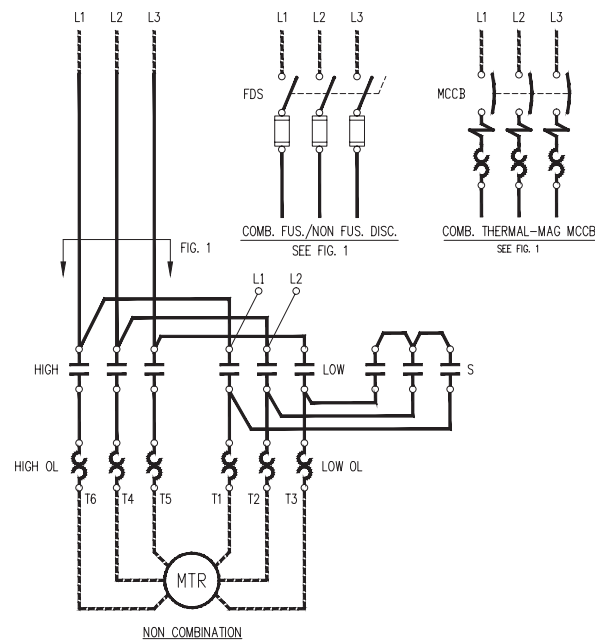
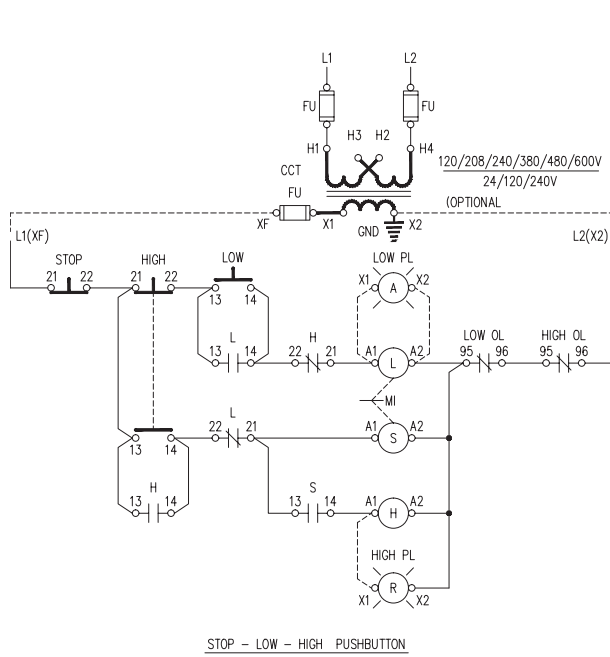

NOTES:

- 1). X2 TERMINAL GROUNDED AS STANDARD, REMOVE IF NOT REQUIRED.
- 2). MI STANDS FOR MECHANICAL INTERLOCK.

Multi Speed - Two Separate Windings (Selective Control)

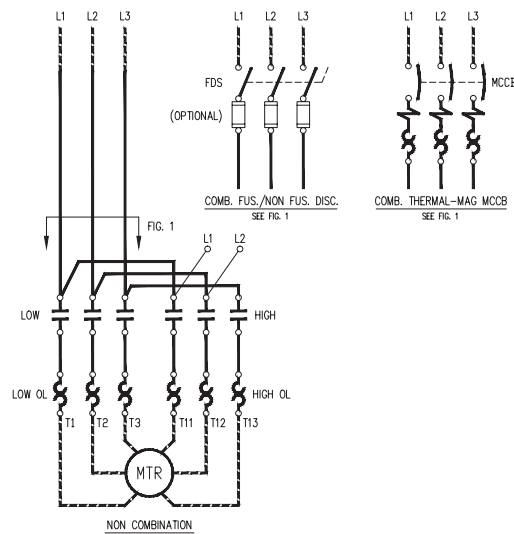
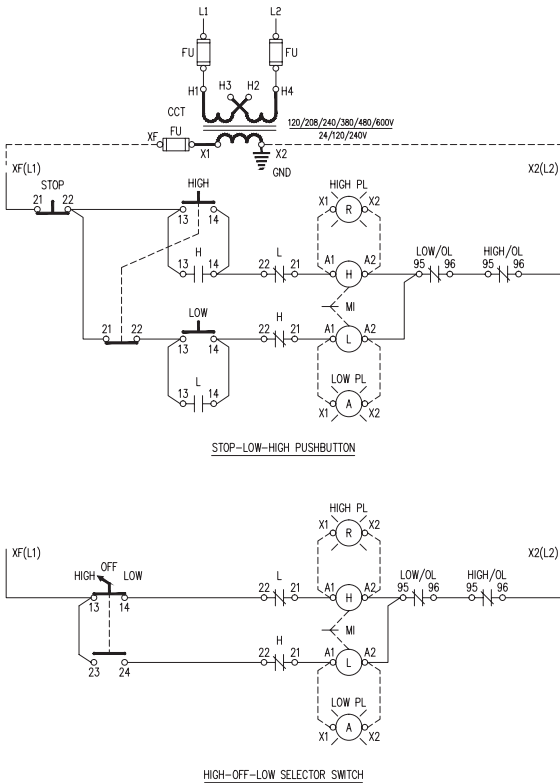

NOTES:

- 1). X2 TERMINAL GROUNDED AS STANDARD, REMOVE IF NOT REQUIRED.
- 2). MI STANDS FOR MECHANICAL INTERLOCK.

Classic Pump Control Panels

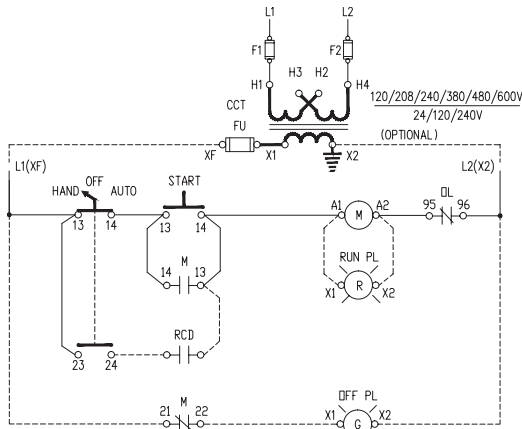

HAND-OFF-AUTO SELECTOR SWITCH WITH START PUSHBUTTON

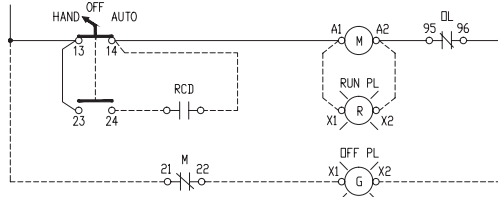

HAND-OFF-AUTO SELECTOR SWITCH

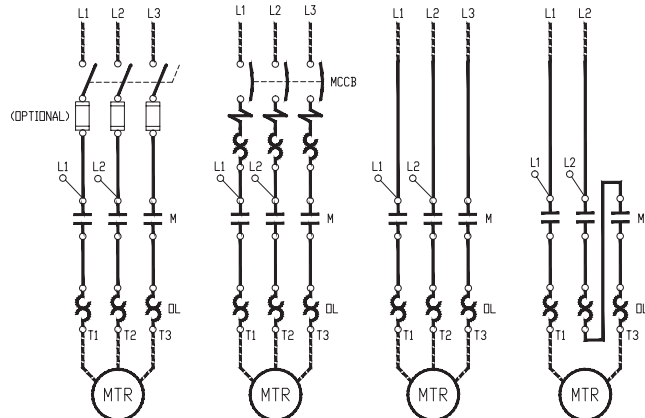

COMB. FUS./NON FUS. DISC. COMB. THERMAL-MAG MCCB NON COMB. 3-PHASE NON COMB. 1-PHASE

- NOTES:
- 1). RCD: STANDS FOR REMOTE CONTROL DEVICE BY CUSTOMER.
 - 2). X2 TERMINAL GROUNDED AS STANDARD, REMOVE GROUND IF NOT REQUIRED
 - 3). DO NOT WIRE CONTROL CIRCUIT TO LINE SIDE OF CONTACTOR WHEN COIL VOLTAGE IS 120V OR LESS

Combination Fusible Switch 3-PH FVNR Duplex Alternating Panel

AC Control w/ D7 Series Pilot Devices

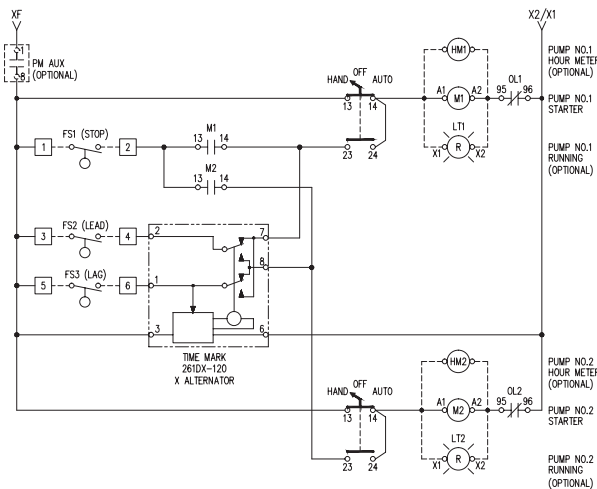

- FS1 - "STOP" FLOAT SWITCH
 FS2 - "LEAD" FLOAT SWITCH
 FS3 - "LAG" FLOAT SWITCH

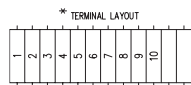
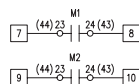

* TERMINAL LAYOUT
 COPPER ONLY
 TIGHTENING TORQUE [5-6.2 lb-in]

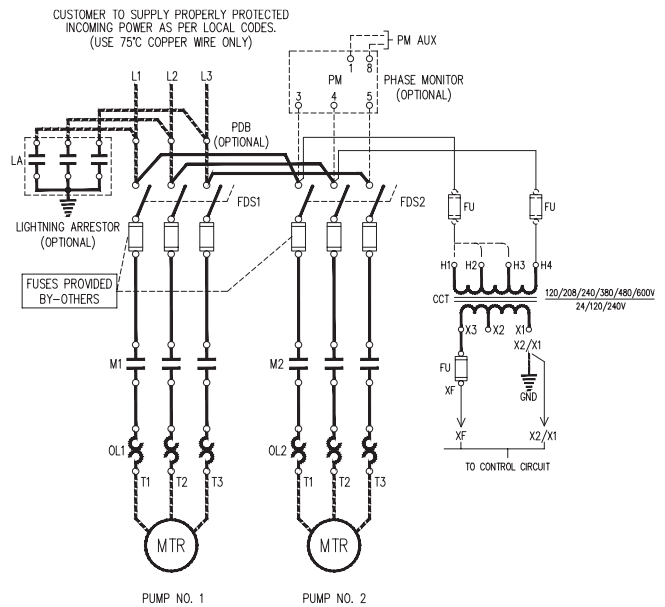

CUSTOMER TO SUPPLY PROPERLY PROTECTED INCOMING POWER AS PER LOCAL CODES. (USE 75°C COPPER WIRE ONLY)

- NOTE:
- 1). X2 TERMINAL GROUNDED AS STANDARD, REMOVE IF NOT REQUIRED.

CAL7 Lighting Contactor - 4 Pole

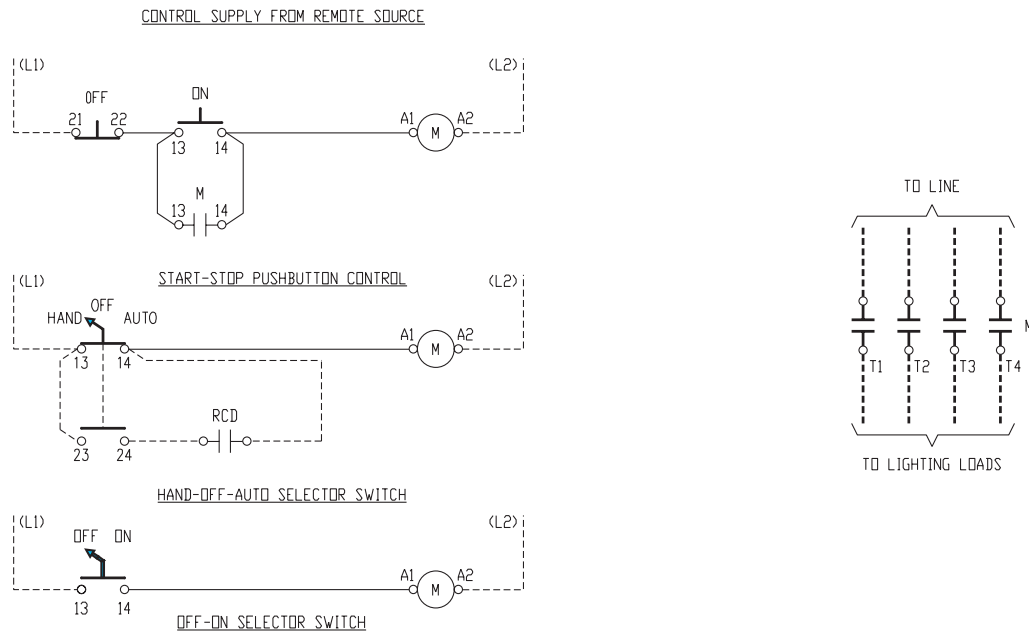

NOTES:
1.) RCD: STANDS FOR REMOTE CONTROL DEVICE BY CUSTOMER.

CAL7 Lighting Contactor - 8 Pole

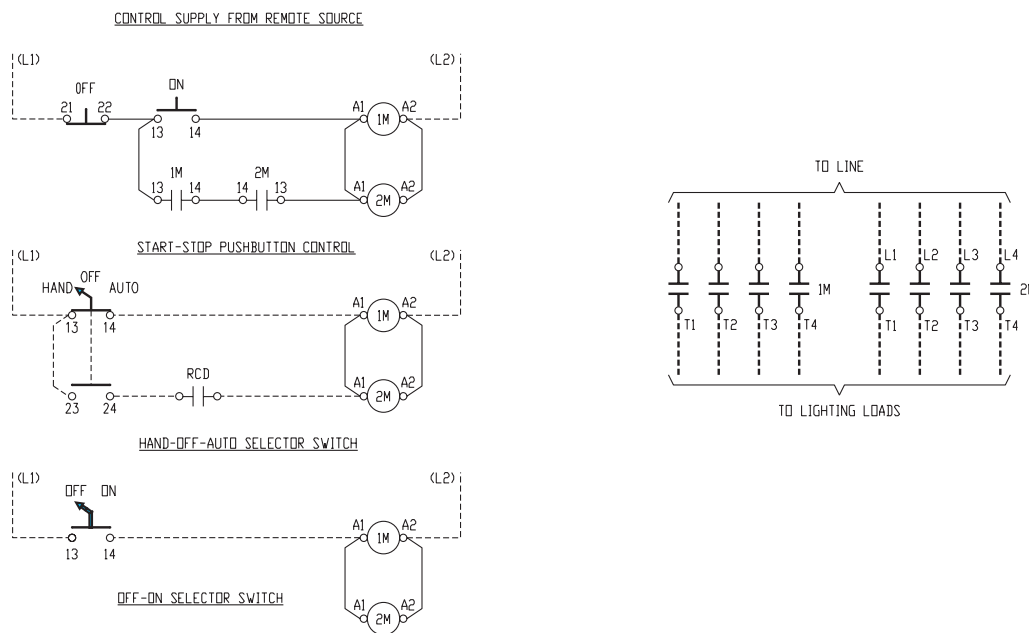

NOTES:
1.) M1: STANDS FOR MECHANICAL INTERLOCK.
2.) RCD: STANDS FOR REMOTE CONTROL DEVICE BY CUSTOMER.

C
Starters & Enclosed Products

CAL7 Lighting Contactor with CAV Mechanical Latch B

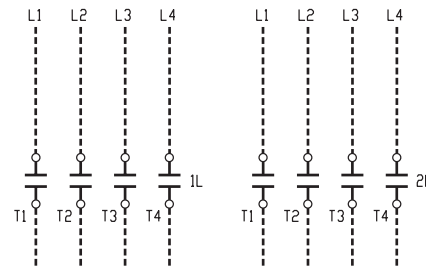
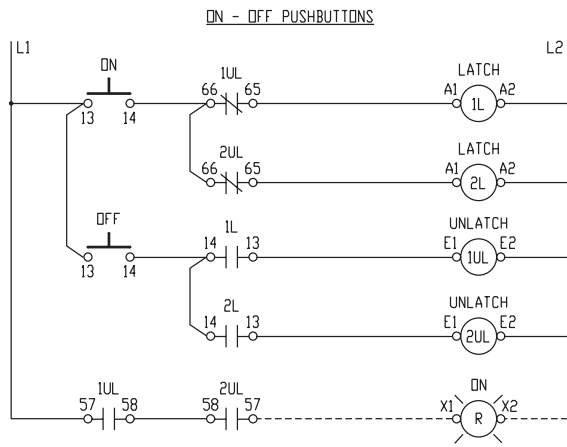

CAV OPERATION:

CAV CONSISTS OF CA7 CONTACTOR "L" WITH CV7-11 MECHANICAL LATCH "UL". AFTER "L" COIL IS ENERGIZED AND THE CONTACTOR CLOSES, THE MECHANICAL LATCH MECHANICALLY LOCKS THE CONTACTOR IN THE CLOSED POSITION. THE "L" COIL IS THEN DE-ENERGIZED BY THE COIL CLEARING CONTACT "UL" TO REMOVE VOLTAGE. AFTER THE "UL" COIL IS ENERGIZED, THE MECHANICAL LATCH RELEASES THE CONTACTOR. THE "UL" COIL IS IMMEDIATELY DE-ENERGIZED BY THE COIL CLEARING CONTACT "L" TO REMOVE VOLTAGE. THE CONTACTOR IS NOW OPEN.

NOTES:

- 1) "L": CA7 CONTACTOR.
- 2) "UL": CV7-11 MECHANICAL LATCH. (THE CV7 COIL IS MOMENTARY RATED ONLY)
- 3) CONNECT CONTROL CIRCUIT DIRECTLY TO LINE (L1) & (L2) OF CONTACTOR IF COIL VOLTAGE IS 208V OR ABOVE.
- 4) DO NOT CONNECT CONTROL CIRCUIT DIRECTLY TO LINE (L1) & (L2) OF CONTACTOR IF COIL VOLTAGE IS 120V OR LESS. (FACTORY WIRING STANDARD)
- 5) X1 & X2 INDICATES CONNECTION TO REMOTE CONTROL SOURCE.

Enclosure Dimensions

- See enclosure drawings by Figure No. on the opposite page
- Dimensions are in decimal inches
- Dimensions not intended for manufacturing purposes
- For other dimensions, please refer to factory

TYPE 1 - GENERAL PURPOSE ENCLOSURE

Encl. ID Dim.	Figure No.	Enclosure Size			Mtg Depth D	Mtg Centers		Panel Size Sub-Pan		
		A	B	C		E	F	H		
A	2	10	8	6	5.5	7	7	8.25	6.25	N/A
B	2	12	10	6	5.5	9	9	10.25	8.25	N/A
C	2	16	12	6.62	6	7	13.88	13	10.5	N/A
C2	2	16	12	8.62	8	7	13.88	13	10.5	N/A
D	2	20	16	6.62	6	11	17.88	17	14.5	N/A
D3	2	20	16	8.62	8	11	17.88	17	14.5	N/A
E	2	24	20	8.62	8	15	21.88	21	18.5	N/A
E2	2	24	20	10.62	10	15	21.88	21	18.5	N/A
F	2	30	24	8.62	8	16.75	27.5	26	22.5	N/A
G	2	30	24	12.62	12	16.75	27.5	26	22.5	N/A
H	2	36	30	12.62	12	22.75	33.5	32	28.5	N/A
I	2	42	30	13.25	12.09	22.76	39.88	39	27	N/A
J	2	48	36	13.25	12.09	28.76	45.88	45	33	N/A
J2	(Type 12 Enclosure, See Table Below)									
K2	(Type 12 Enclosure, See Table Below)									
K3	(Type 12 Enclosure, See Table Below)									
M	2	10	8	6	5.5	7	7	8.25	6.25	N/A
O	2	14	12	6	5.47	10.98	11.02	12.25	10.25	N/A
S	2	36	24	8.62	8	16.75	33.5	32	22.5	N/A

TYPE 12 - INDUSTRIAL DUST TIGHT ENCLOSURE

Encl. ID Dim.	Figure No.	Enclosure Size			Mtg Depth D	Mtg Centers		Panel Size Sub-Pan		
		A	B	C		E	F	H		
C2	4	16	14	8	7.53	12	16.75	14.75	12.88	17.5
C3	4	16	14	10	9.53	12	16.75	14.75	12.88	17.5
H	5	36	30	12	12	24	37.25	33	27	38.5
I	5	42	30	12	12	24	43.25	39	27	44.5
J	5	48	36	12	12	30	49.25	45	33	50.5
J2	5	48	36	16	16	30	49.25	45	33	50.5
K2	5	60	36	16	16	30	61.25	57	33	62.5
K3	5	60	36	12	12	30	61.25	57	33	62.5
L	4	8	6	6	5.53	4	8.75	6.75	4.88	9.5
M	4	10	8	6	5.53	6	10.75	8.75	6.88	11.5
O	4	14	12	6	5.53	10	14.75	12.75	10.88	15.50
Q	5	20	16	8	8	10	21.25	17	13	22.5
Q2	5	20	16	10	10	10	21.25	17	13	22.5
R	5	24	20	8	8	14	25.25	21	17	26.5
R2	5	24	20	10	10	14	25.25	21	17	26.5
T	5	30	24	10	10	18	31.25	27	21	32.5
W	5	42	36	12	12	30	43.25	39	33	44.5

TYPE 3R - RAIN TIGHT ENCLOSURE

Encl. ID Dim.	Figure No.	Enclosure Size			Mtg Depth D	Mtg Centers		Panel Size Sub-Pan		
		A	B	C		E	F	H		
L	7	10	8	6	5.46	3	11	8.25	6.25	12
M	7	12	10	6	5.46	3	13	10.25	8.25	14
O	8	18	18	10	8.1	13	19	15	15	20
Q	8	20	20	8	6.98	13	21	17	17	22
R	8	24	20	8	6.98	13	25	21	17	26
R2	8	24	24	10	8.81	13	25	21	21	26
T	5	30	24	10	8.81	13	31	27	21	32.5
H	8	36	30	12	10.97	27	37	33	27	38
I	8	42	30	12	10.97	27	43	39	27	44
W	8	42	36	12	10.97	27	43	39	33	44
J	8	48	36	12	10.97	27	49	45	33	50

C Starters & Enclosed Products

Enclosure Dimensions

See dimension tables on previous page.

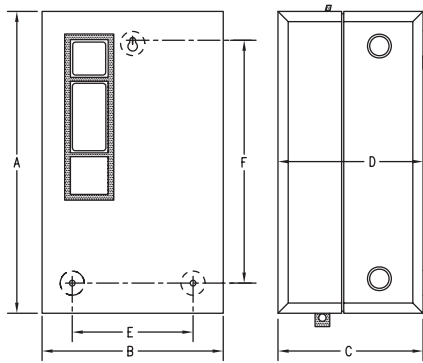

FIGURE NO. 1

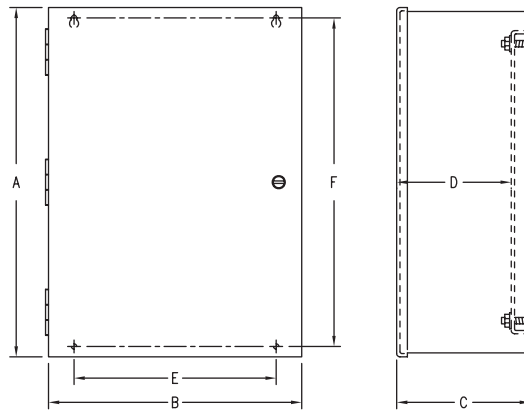

FIGURE NO. 2

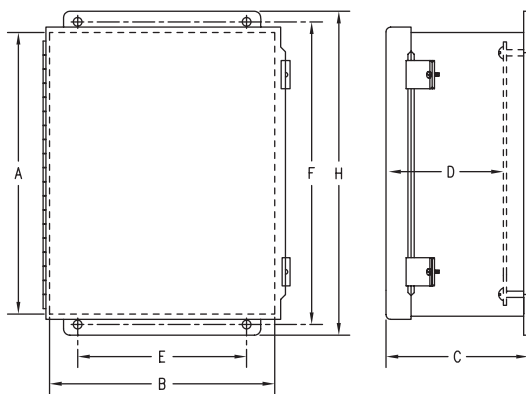

FIGURE NO. 4

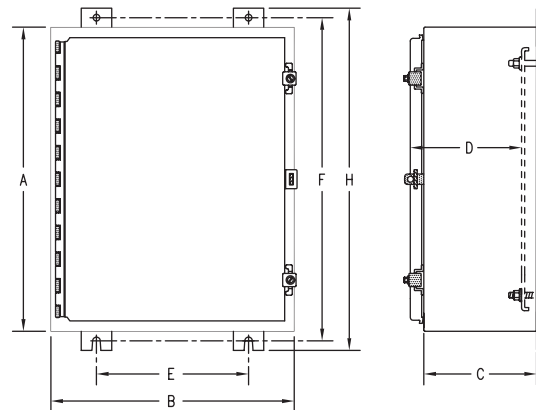

FIGURE NO. 5

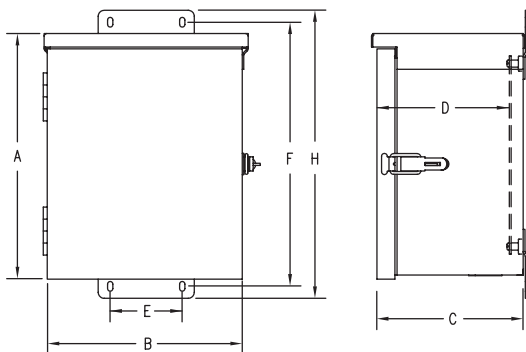

FIGURE NO. 7

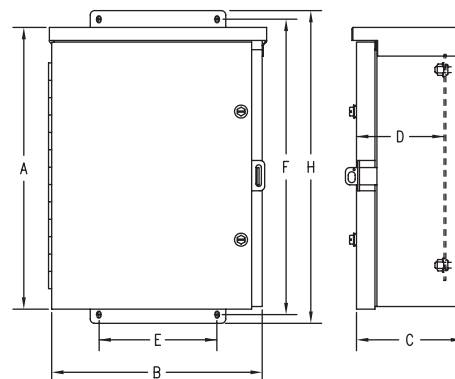

FIGURE NO. 8

Enclosure Dimensions

- See enclosure drawings by Figure No. on the opposite page
- Dimensions are in decimal inches
- Dimensions not intended for manufacturing purposes
- For other dimensions, please refer to factory

TYPE 4 - WATER TIGHT ENCLOSURE

Encl. ID Dim.	Figure No.	Enclosure Size			Mtg Depth D	Mtg Centers		Panel Size Sub-Pan		
		A	B	C		E	F	H		
C	10	16	12	6	6	9.5	17.24	13	9	18.5
C2	10	16	12	8	8	9.5	17.24	13	9	18.5
H	10	36	30	12	12	24	37.24	33	27	38.5
J	10	48	36	12	12	30	49.24	45	33	50.5
M	9	10	8	6	5.53	6	10.75	8.75	6.88	11.5
N	9	12	10	5	4.53	8	12.75	10.75	8.88	13.5
O	9	14	12	6	5.53	10	14.75	12.75	10.88	15.5
Q	10	20	16	8	8	10	21.24	17	13	22.5
Q2	10	20	16	10	10	10	21.24	17	13	22.5
R	10	24	20	8	8	14	25.24	21	17	26.5
R2	10	24	20	10	10	14	25.24	21	17	26.5
T	10	30	24	10	10	18	31.24	27	21	32.5

TYPE 4X - WATER TIGHT, CORROSION RESISTANT, NON-METALLIC ENCLOSURE

Encl. ID Dim.	Figure No.	Enclosure Size			Mtg Depth D	Mtg Centers		Panel Size Sub-Pan		
		A	B	C		E	F	H		
S1	13	7.32	5.94	5.50	4.52	5.16	6.54	4.13	5.5	N/A
U1	13	11.89	7.32	6.93	5.85	6.54	11.10	5.47	8.98	N/A
V1	13	14.65	11.89	6.93	5.85	11.10	13.86	10	11.73	N/A
V2	13	14.65	11.89	9.69	8.23	11.10	13.86	10	11.73	N/A
W1	13	23.74	14.65	6.93	5.85	13.78	22.91	12.76	20.78	N/A
W2	13	23.74	14.65	9.69	8.23	13.78	22.91	12.76	20.78	N/A
X1	14	30.25	24.63	11.80	10.25	18	31.95	27	21	33.13
A2	14	36.25	30.63	13.8	12.25	24	37.58	33	27	39.13
Y1	14	48.25	36.63	13.8	12.25	30	49.58	45	33	50.82
Z1	14	60.25	36.63	13.8	12.25	30	61.58	57	33	62.82

C
Starters & Enclosed Products

Enclosure Dimensions

See dimension tables on previous page.

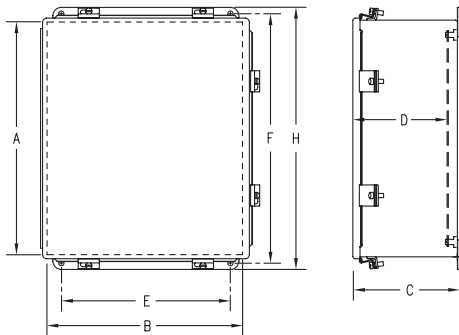

FIGURE NO. 9

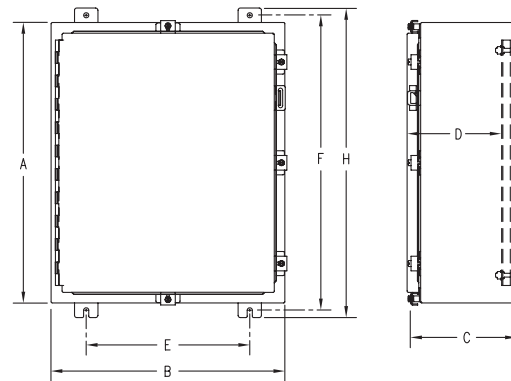

FIGURE NO. 10

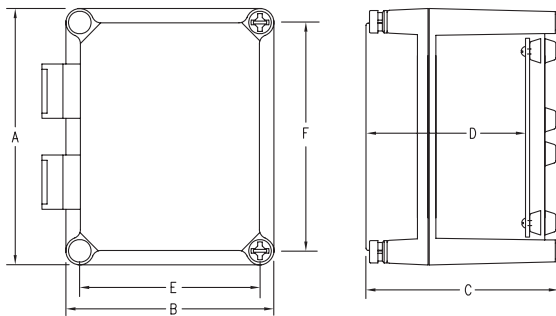

FIGURE NO. 13

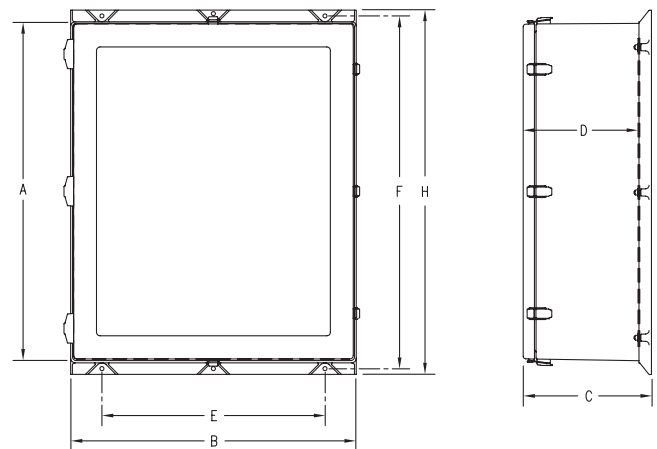

FIGURE NO. 14



Starters & Enclosed Products

Type 7/9 - Explosion Proof Enclosure Dimensions

Dimensions are in decimal inches. Dimensions not intended for manufacturing purposes.

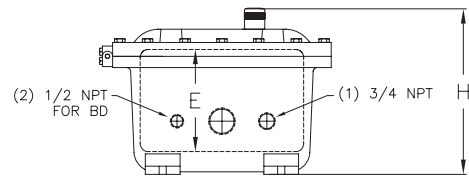
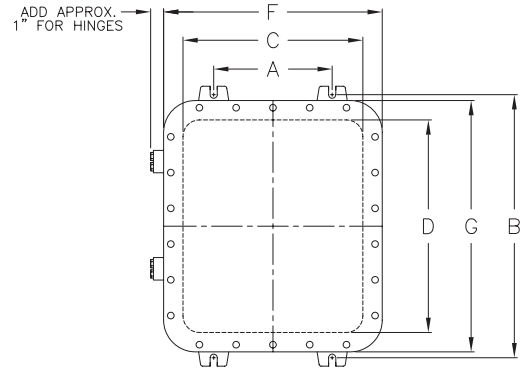
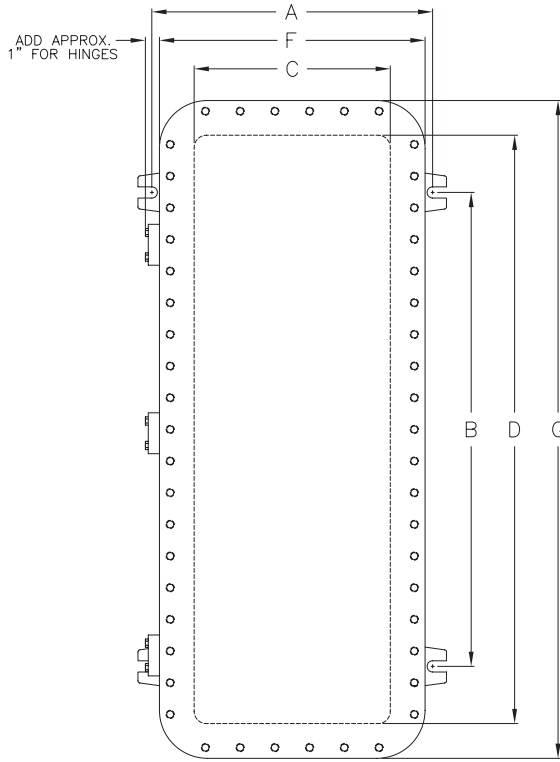

FIGURE NO. 2

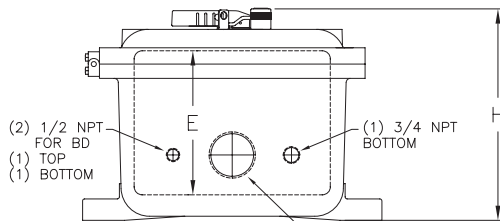

FIGURE NO. 1

(1) TOP
(1) BOTTOM

Encl. ID Dim.	Figure No.	Mounting Dims		Inside Dims			Overall Dims			Panel Size Sub-Pan		Conduit Entry Top & Bot
		A	B	C	D	E	F	G	H			
A7	2	7.25	14.50	10.0	12.0	7.25	13.38	15.38	10.13	10.88	8.88	1.25
B7	2	8.50	27.13	12.0	24.0	8.94	16.25	28.25	12.5	11.0	23.0	2.0
C7	1	15.75	29.0	12.0	36.0	8.94	16.25	40.25	12.94	10.75	34.75	2.5
D7	1	19.75	39.0	16.0	46.0	11.81	20.88	50.88	15.81	14.50	44.50	4.0
E7	2	7.25	16.19	10.0	14.0	6.75	13.38	17.38	9.69	8.88	12.88	1.0
F7	2	8.50	27.13	12.0	24.0	6.94	16.25	28.25	10.50	11.0	23.0	1.5
G7	1	15.75	29.0	12.0	36.0	8.94	16.25	40.25	12.94	10.75	34.75	2.0
H7	1	19.75	39.0	16.0	46.0	11.81	20.88	50.88	15.81	14.50	44.5	4.0

Notes

C

Starters & Enclosed Products

*For Technical Information and Dimensions
please see the online catalog*

